

# TLB Series

## ▶ **SLB-01-P** Split light barriers

- Insensitive to outside light due to optical filtering
- Connection either to constant light amplifier or pulsating light amplifier
- Oil resistant connecting cable
- High resolution
- Scratch-resistant optics cover made of glass
- Sturdy metal housing

In Proud Partnership with Sensor Instruments



For technical support, sales, & distribution within the USA & Canada

www.paquin.com | (800) 831-8217 | paquinsensors@paquin.com



### Design

**Product name:**

**SLB-01-P-500** (transmitter SLB-01-T, receiver SLB-01-R, 8-pin connector, cable l=500 mm)

**SLB-01-P-1000** (transmitter SLB-01-T, receiver SLB-01-R, 8-pin connector, cable l=1000 mm)

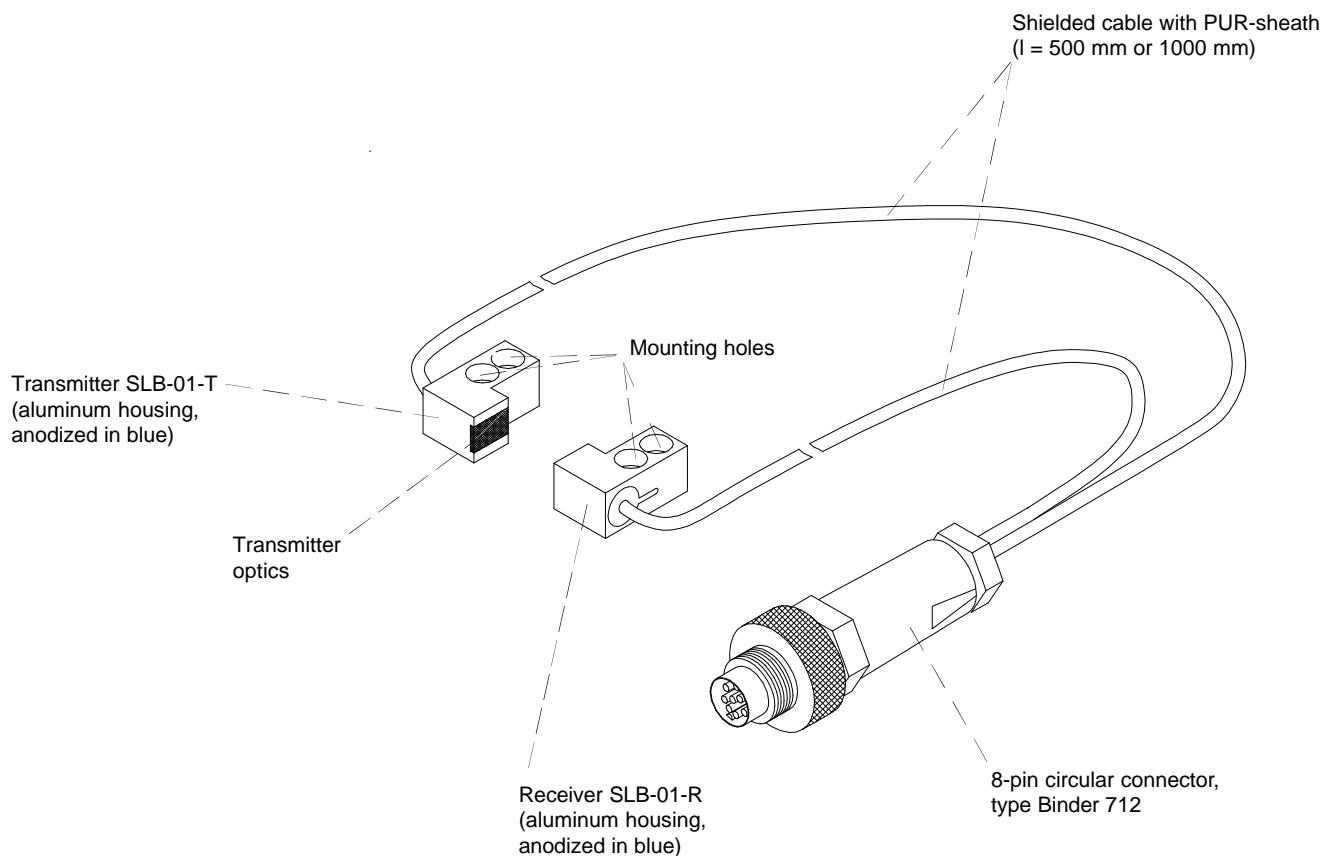



**Technical Data**

<b>Model</b>	<b>SLB-01-P</b>
Transmitter	IR-LED, 905 nm, DC operation: max. opt. power < 0,4 mW, AC operation: medium opt. power < 0,4 mW
Minimum detectable object	typ. 50 µm (DC operation) typ. 300 µm (AC operation)
Light spot dimension (at transmitter output)	typ. 2 mm x 1 mm
Repeatability	typ. 10 µm (DC operation) typ. 100 µm (AC operation)
Maximum range	typ. 30 mm (DC operation) typ. 100 mm (AC operation)
Optics	collimated, beam divergency typ. 100 mrad
Optical filter	Daylight rejection filter RG715
Ambient light	up to 5000 Lux (AC operation)
Cable type	PUR sheath, black, shielded
Cable length	500 mm or 1000 mm
Mechanical protection	IP67
Connector type	8-pin circular connector, type Binder 712
Operating temperature range	-20°C ... +80°C
Storage temperature range	-20°C ... +85°C
Housing	Aluminum, anodized in blue
Housing dimensions	approx. length 9 mm x width 8 mm x heigth 14 mm (see page 3)
EMC test acc. to	IEC - 801...

**Dimensions**

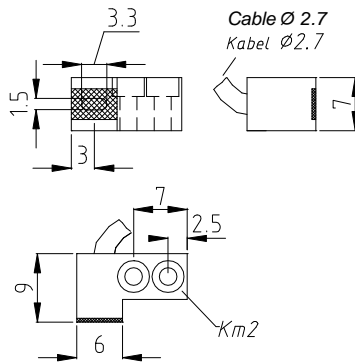
**SLB-01-T (transmitter) and  
SLB-01-R (receiver)**



(All dimensions in mm)

**Connector Assignment**

**Assignment 8-pin circular connector, type Binder 712:**

Pin:	Assignment:
1	n.c.
2	n.c.
3	Transmitter anode
4	Receiver collector
5	Transmitter cathode
6	Receiver emitter
7	n.c.
8	n.c.
Shield	

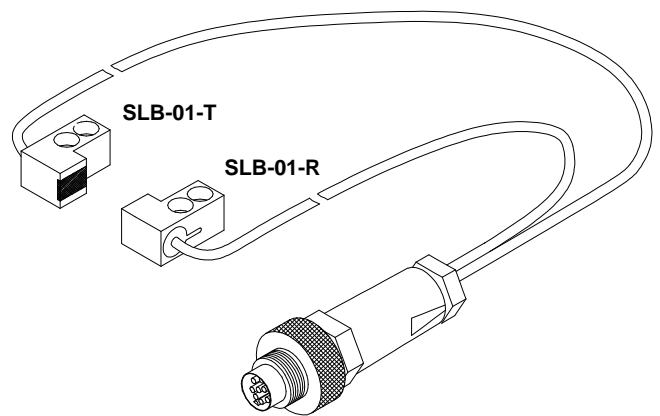
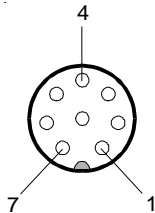

**Product Line**

**Fork light barriers:**

FKB-06-...  
FKB-06-...-P  
FKB-06-...-TPN  
FKB-06-...-TPO

FKB-06-...-BL  
FKB-06-...-BL-P  
FKB-06-...-BL-TPN  
FKB-06-...-BL-TPO

FKB-08-...  
FKB-08-...-P  
FKB-08-...-TPN  
FKB-08-...-TPO

FKB-08-...-BL  
FKB-08-...-BL-P  
FKB-08-...-BL-TPN  
FKB-08-...-BL-TPO

**Split light barriers:**

SLB-01  
SLB-01-P  
SLB-01-TP

SLB-02  
SLB-02-P  
SLB-02-TP

SLB-03  
SLB-03-P  
SLB-03-TP

SLB-04  
SLB-04-P  
SLB-04-TPN  
SLB-04-TPO

SLB-05  
SLB-05-P  
SLB-05-TPN  
SLB-05-TPO

SLB-06  
SLB-06-P  
SLB-06-TP

SLB-08  
SLB-08-P  
SLB-08-TP

**Pulsating light amplifiers:**

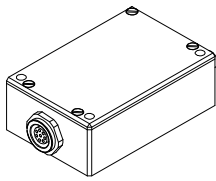

**TLB-CON5**

Connecting cables:  
cab-M8/4-g-2 (2m)  
cab-las5/PC (5m)

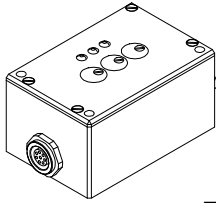

**TLB-CON6**

Connecting cable:  
cab-las8/702-fem (2m)

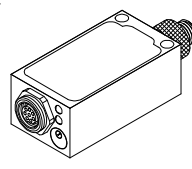

**TLB-CON8**

Connecting cable:  
cab-M8/3-g-2 (2m)

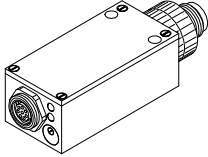

**TLB-CON12**

Connecting cable:  
cab-M12/5-g-2-shd (2m)

**Constant light amplifiers:**

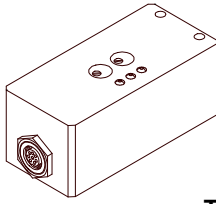

**TLB-CON2**

Connecting cable:  
cab-las8/702-fem (2m)

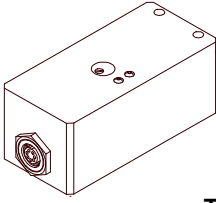

**TLB-CON11**

Connecting cable:  
cab-las8/702-fem (2m)

