

# SPECTRO Series

## ► SPECTRO-2-FIO-(IR2+IR3)/IR

- Detection of the water content of various materials
- Transmitter channel 0 (IR2): IR-LED (950nm)  
Transmitter channel 1 (IR3): IR-LED (1450nm)  
Receiver channel 0 (IR): IR (900nm ... 1700nm)
- Evaluation mode: Normed evaluation  
Humidity measurement (HYGROMETRY)
- Fast evaluation methods in DC-operation available (up to 130kHz)
- Insensitive to outside light (in AC-operation)
- Parameterizable via Windows® software
- RS232 interface (RS232/Ethernet converter and RS232/USB converter available)
- Suitable for use in hazardous areas (fiber optics)
- 1 analog output (0V... +10V or 4mA...20mA)
- 2 digital outputs (0V/+24V)
- External trigger input and teach input
- Linearization by means of an editable linearization curve

In Proud Partnership with Sensor Instruments

**PAQUIN**  
SENSORS

For technical support, sales, & distribution  
within the USA & Canada

www.paquin.com | (800) 831-8217 | paquinsensors@paquin.com

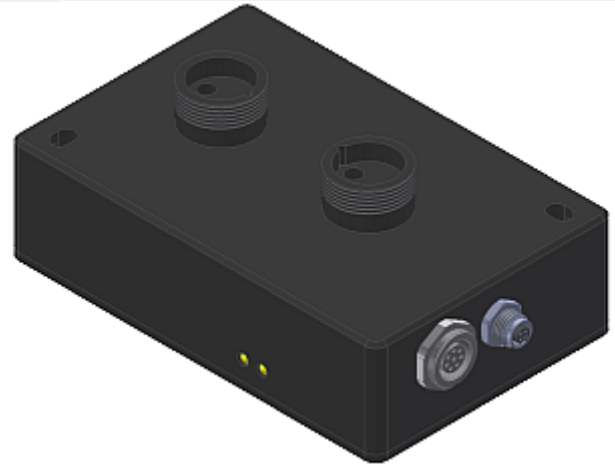

## Design

### Product name:

### SPECTRO-2-FIO-(IR2+IR3)/IR\*

(incl. Windows® PC software SPECTRO2-Scope)

\*2-channel system

(Transmitter IR2 + Transmitter IR3)/Receiver

**(IR2+IR3)/IR:**

Transmitter: IR2=IR-LED (950nm) + IR3=IR-LED (1450nm)

Receiver: IR (900nm ... 1700nm)

### Accessories: (p. 8-10)

### BICONE fiber optics Combination of fiber optics Optical frontends

KL-D-45°/0°-22-d80/d110-A3.0 or

KL-D-0°/45°-85-1200-A3.0-VIS

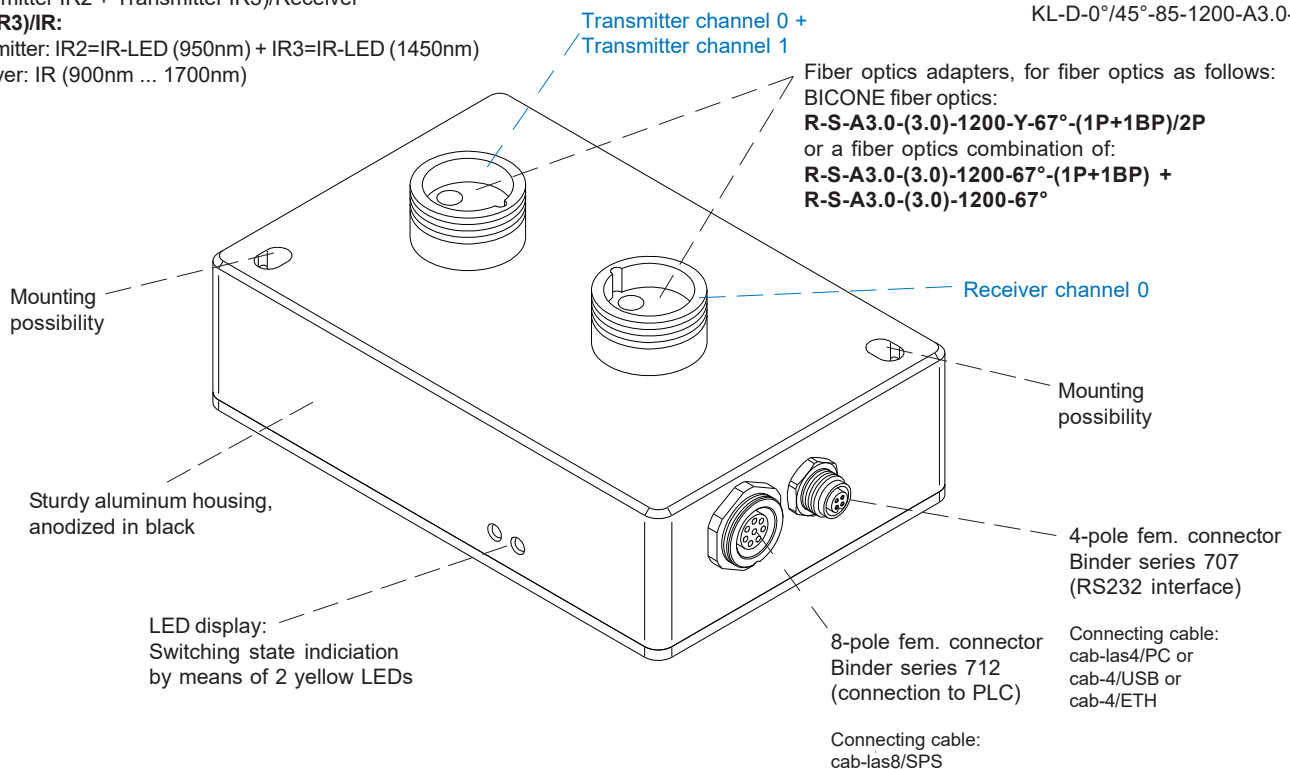



**Technical Data**

Model	SPECTRO-2-FIO-(IR2+IR3)/IR		
Voltage supply	+24VDC (± 10%), reverse polarity protected, overcurrent protected		
Current consumption	< 160 mA		
Max. switching current	100 mA, short circuit proof		
Switching state indication	2 yellow LED visualize the physical state of the outputs OUT0 and OUT1		
Digital inputs (2x)	IN0 and IN1 (Pin 3 and 4): digital (0V/+24V)		
Digital outputs (2x)	OUT0 and OUT1 (Pin 5 and 6): digital (0V/+24V), npn/pnp-able (bright-/dark-switching, can be switched)		
Analog output (1x)	ANALOG (Pin 7): voltage 0 ... +10V or current 4 ... 20mA, adjustable via PC software		
Interface	RS232		
Pulse lengthening	0 ... 100 ms, adjustable via PC software		
Averaging	max. 32768 values, adjustable via PC software		
Scan frequency (LED mode AC or DC, can be switched via PC software)	LED mode AC (depends on parameterization):		LED mode DC (depends on parameterization):
	Frequency [Hz]	Digital outputs	Analog output
	Max. 50 000	Off	Off
	Max. 48 000	On	Off
	Max. 42 000	Off	On
	Max. 41 000	On	On
	Measurements were made with the smallest gain at the receiver (AMP1). At the highest gain (AMP8), the frequency is reduced by a factor of 10.		The frequency is independent of the gain set at the receiver.
Switching frequency	typ. 60 kHz		
Analog band width	typ. 90 kHz (-3 dB)		
Transmitter (light source)	Transmitter channel 0: IIR2 = R-LED (950 nm) Transmitter channel 1: IR3 = IR-LED (1450 nm)		
Receiver	Receiver channel 0: Photo diode with IR filter (900 nm ... 1700 nm)		
Transmitter control	can be switched via PC software: AC operation (LED MODE-AC), DC operation (LED MODE-DC)		
Object distance (measurement range)	with reflected light fiber optics: typ. 1 mm ... 50 mm with attachment optics KL-D-45°/0°-22-d80/d110-A3.0: 22 mm with attachment optics KL-D-0°/45°-85-1200-A3.0-VIS: 85 mm		
Receiver gain setting	8 steps (AMP1 ... AMP8), adjustable via PC software		
Ambient light	max. 5000 Lux		
Size of light spot	depends on fiber optics and attachment optics (cf. catalog FIO series)		
Reproducibility	2 digits at 12-bit A/D conversion		
Housing dimensions	LxWxH approx. 100 mm x 65 mm x 38 mm (incl. fiber optics connector M18x1, without connectors)		
Housing material	aluminum, anodized in black		
Enclosure rating	IP64		
Connecting cables	to PLC: cab-las8/SPS or cab-las8/SPS-w to PC/RS232 interface: cab-las4/PC or cab-las4/PC-w to PC/USB interface: cab-4/USB or cab-4/USB-w to PC/Ethernet interface: cab-4/ETH		
Type of connector	connection to PLC: 8-pole fem. connector (Binder 712) connection to PC: 4-pole fem. connector (Binder 707)		
Operating temp. range	-20°C ... +55°C		
Storage temp. range	-20°C ... +85°C		
EMC test acc. to	DIN EN 60947-5-2		

Dimensions

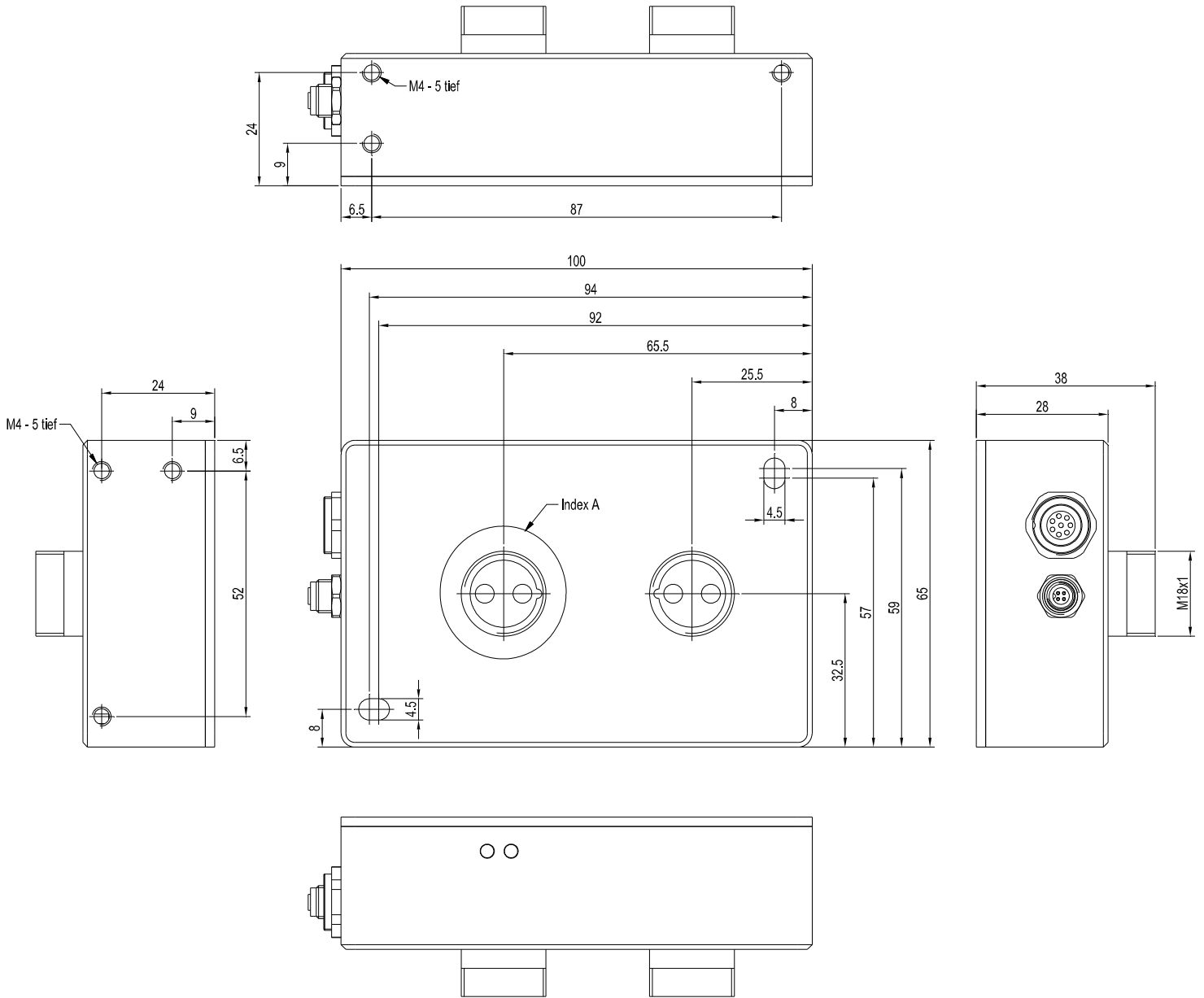

All dimensions in mm



Connector Assignment

Connection to PLC:

8-pole fem. connector Binder Series 712

Pin:	Color:	Assignment:
1	white	GND (0V)
2	brown	+24VDC ( $\pm 10\%$ )
3	green	IN0 (Digital 0: 0 ... 1V, Digital 1: +Ub - 10%)
4	yellow	IN1 (Digital 0: 0 ... 1V, Digital 1: +Ub - 10%)
5	grey	OUT0 (Digital 0: Type 0 ... 1V, Digital 1: Type +Ub - 10%)
6	pink	OUT1 (Digital 0: Type 0 ... 1V, Digital 1: Type +Ub - 10%)
7	blue	ANALOG (0 ... +10V or 4 ... 20mA)
8	red	n.c.

Connecting cable:

- cab-las8/SPS-(length)
- cab-las8/SPS-w-(length) (angle type, 90°)
- (standard length 2m)

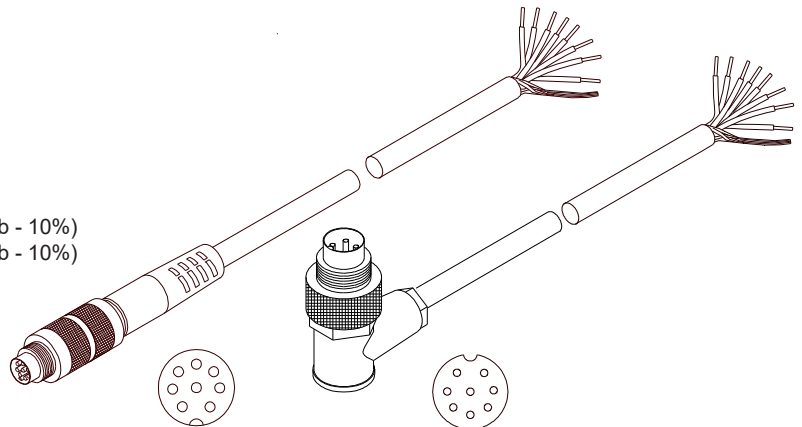

cab-las8/SPS-...  
(max. length 25m,  
outer jacket: PUR)

cab-las8/SPS-w-...  
(max. length 25m,  
outer jacket: PUR)

Connection to PC:

4-pole fem. connector Binder Series 707

Pin:	Assignment:
1	+24VDC (+Ub, OUT)
2	GND (0V)
3	RxD
4	TxD

Connection via RS232 interface at the PC:

Connecting cable:

- cab-las4/PC-(length)
- cab-las4/PC-w-(length) (angle type 90°)
- (standard length 2m)

alternative:

Connection via USB interface at the PC:

USB converter (incl. driver software):

- cab-4/USB-(length)
- cab-4/USB-w-(length) (angle type 90°)
- (standard length 2m)

alternative:

Connection to local network via Ethernet bus:

Ethernet converter (incl. software „SensorFinder“):

- cab-4/ETH-500
- (standard length 0.5m)

Optional: External CAT5 cable, e.g.

- cab-eth/M12D-RJ45-flx-(length)

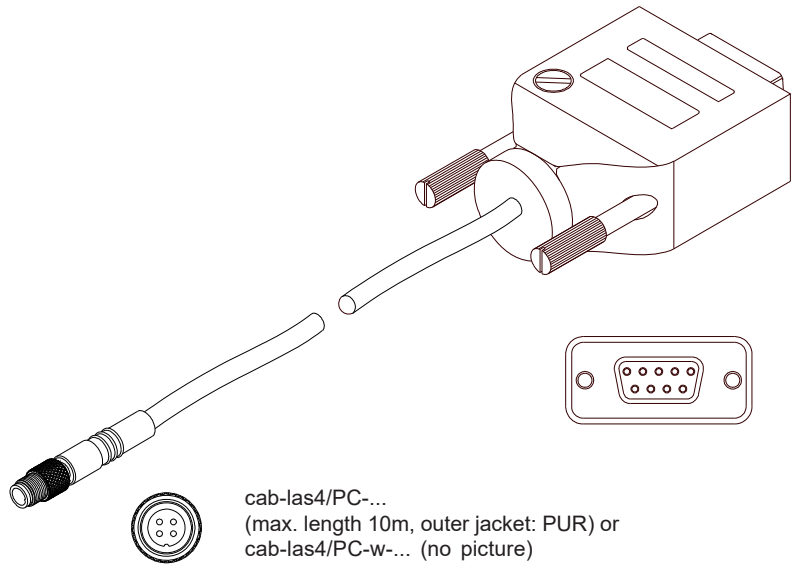

cab-las4/PC-...  
(max. length 10m, outer jacket: PUR) or  
cab-las4/PC-w-... (no picture)  
(max. length 5m, outer jacket: PUR)

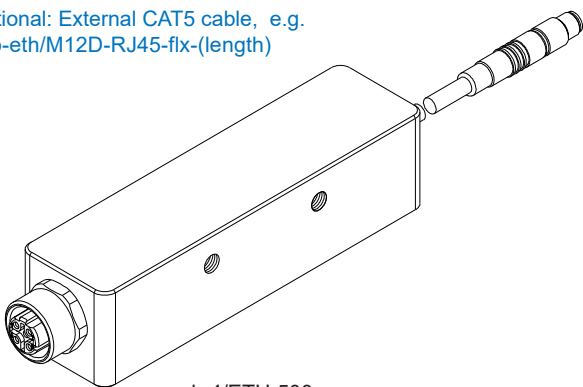

cab-4/ETH-500  
(length 0.5m, outer jacket: PUR)  
4-pole M12 fem. conn. (D-coded)  
for connection of an external  
CAT5 cable, e.g.  
cab-eth/M12D-RJ45-flx-(length)

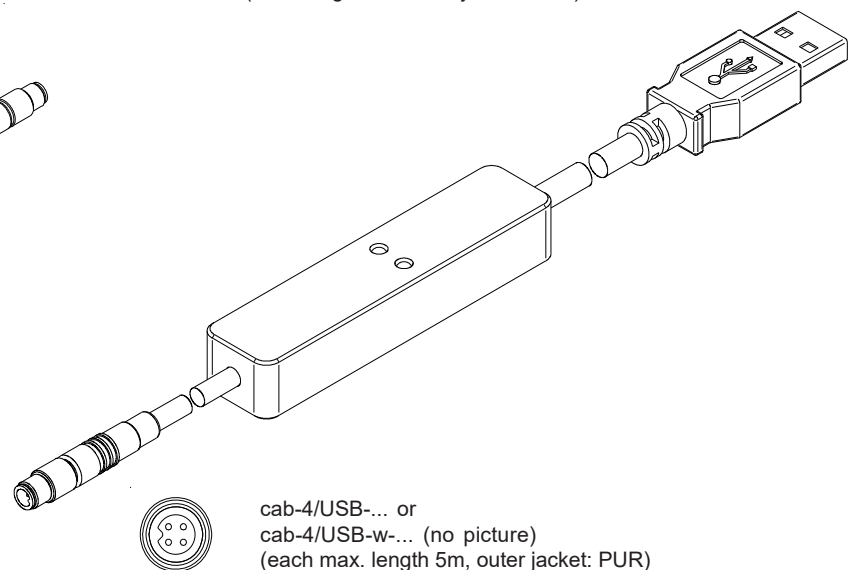

cab-4/USB-... or  
cab-4/USB-w-... (no picture)  
(each max. length 5m, outer jacket: PUR)



## LED Display

### LED display:

By means of the two LEDs the physical state of the two outputs OUT0 and OUT1 is visualized:

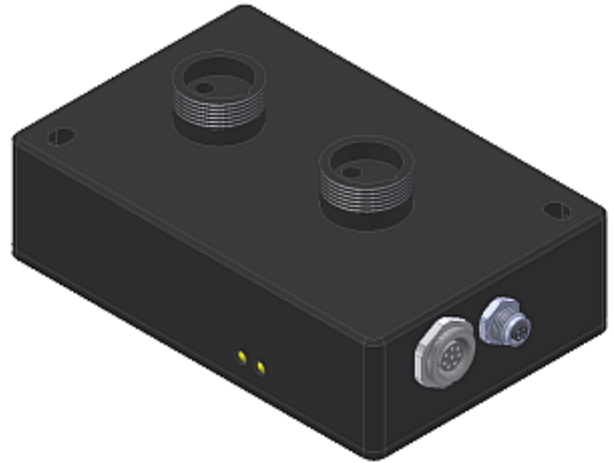
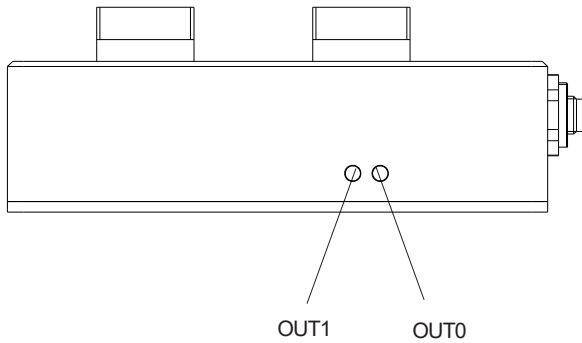

## Measuring Principle

### Measuring principle of the sensors of SPECTRO-2 series:

The sensors of the SPECTRO-2 series feature a two-channel design, which means they acquire the analog signals of two receivers and evaluate these signals. They also have two independently adjustable transmitter sources. Various light sources such as e.g. white light, UV light, or IR light, are available as transmitters. The receiver is correspondingly matched to the transmitter. The acquired analog signal is provided through a voltage output or a current output.

The software can be used to select various evaluation modes for the analog signal.

The status of the output signal is provided through 2 digital outputs in accordance with the selected evaluation mode.

A digital input allows external "teaching" of the sensor.

An additional input allows the "freezing" of the analog output signal upon a positive input edge.

The SPECTRO-2 sensor allows highly flexible signal acquisition. The sensor, for example, can be operated in alternating-light mode (AC mode), which means the sensor is not influenced by external light, or in constant-light mode (DC mode), which provides outstanding high-speed sensor operation. An OFF function deactivates the sensor's integrated light source and changes to DC mode, which allows the sensor to detect so-called "self-luminous objects". With the stepless adjustment of the integrated light source, the selectable gain of the receiver signal, and an INTEGRAL function the sensor can be adjusted to almost any surface or any "self-luminous object".

A micro-controller performs 12-bit analog/digital conversion of the analog signal, which allows recording and evaluation of the signal. Furthermore the SPECTRO-2 sensor offers various options for intelligent signal processing such as e.g. dirt accumulation compensation.

Parameters and measurement values can be exchanged between PC and sensor either through RS232 or Ethernet (using an Ethernet converter). Through the interface all the parameters can be stored in the non-volatile EEPROM of the sensor.

The PC software facilitates the parameterisation, diagnostics, and adjustment of the sensor system (oscilloscope function). The software furthermore provides a data recorder function that automatically records data and stores them on the hard disk of the PC.

SPECTRO-2 sensors are temperature-compensated over a range of 0°C to 80°C.

When parameterisation is finished, the sensor continues to operate with the current parameters in STAND-ALONE mode without a PC.



Parameterization

**Windows® user interface:**

(The current software version is available for download on our website.)

The PC software SPECTRO2-Scope facilitates the parameterization, the diagnosis, and the adjustment of the sensor system (oscilloscope function). Moreover, the software features a data recorder function that allows the automatic recording of recorded data and the saving of those at the hard disk of the PC.

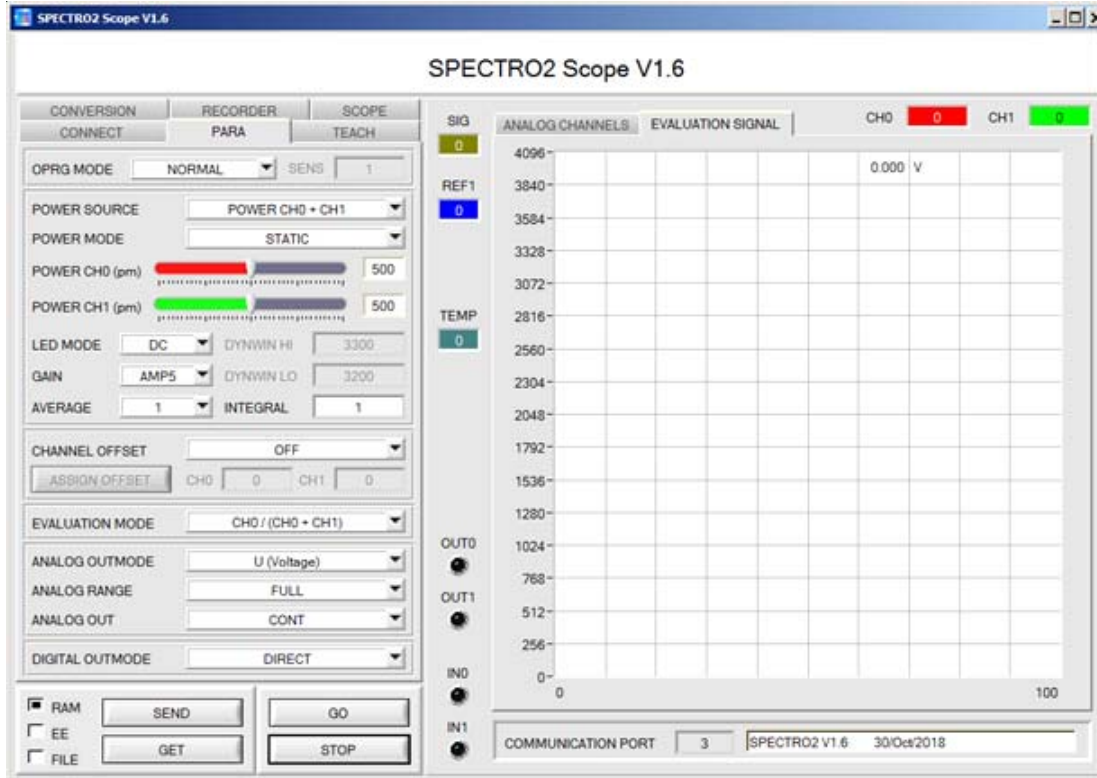

Parameters and measurement values can be exchanged between PC and sensor either through RS232 or Ethernet (using the Ethernet converter cab-4/ETH-500). Through the interface all the parameters can be stored in the non-volatile EEPROM of the sensor.



The SCOPE tab visualizes an oscilloscope.





## Firmware Update

### Firmware update by means of the software „FirmwareLoader“:

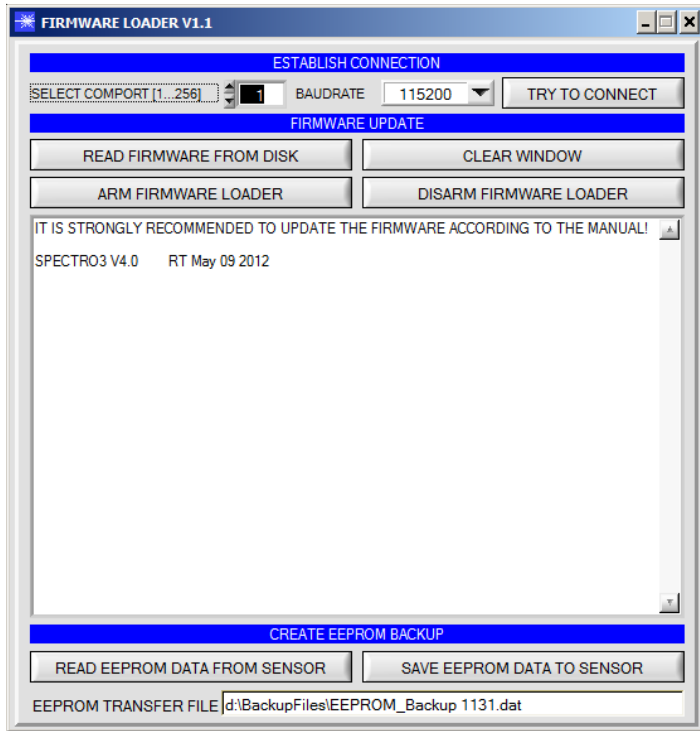

The software „Firmware Loader“ allows the user to perform an automatic firmware update. The update will be carried out through the RS232 interface.

An initialisation file (xxx.ini) and a firmware file (xxx.elf.S) are required for performing a firmware update. These files can be obtained from your supplier. In some cases an additional firmware file for the program memory (xxx.elf.p.S) is also needed, and this file will be automatically provided together with the other two files.

**BICONE Fiber Optics**

R-S-A3.0-(3.0)-1200-Y-67°-(1P+1BP)/2P

Detail B

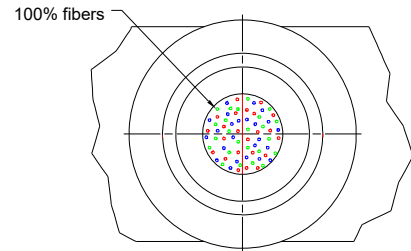

Detail A

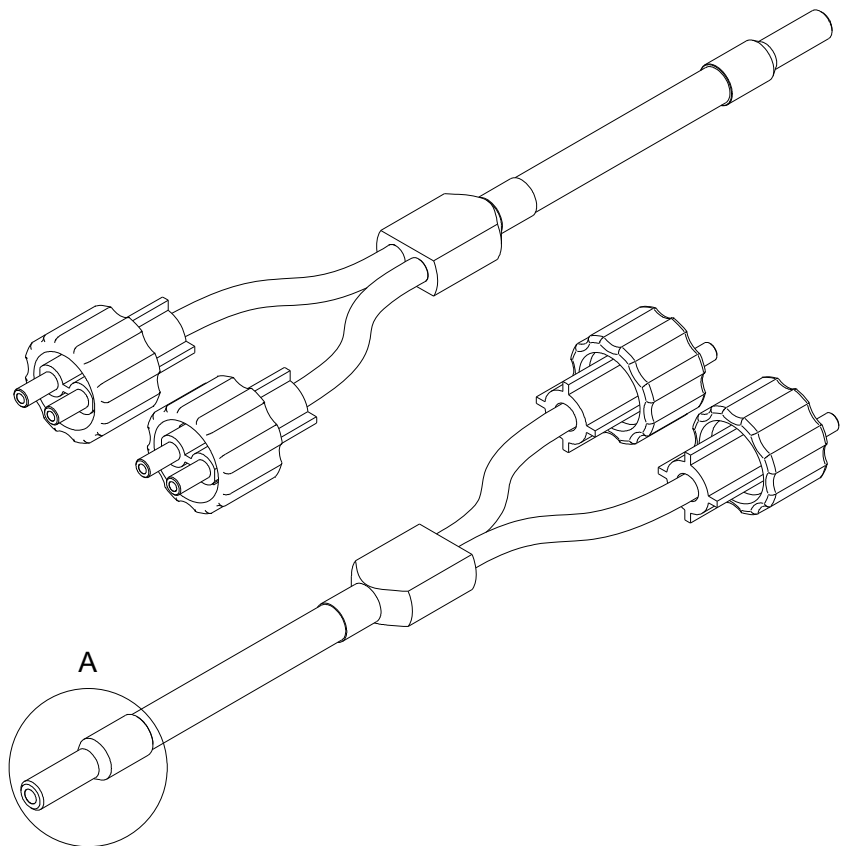
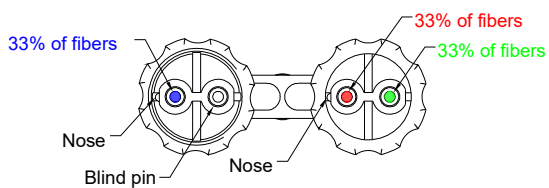
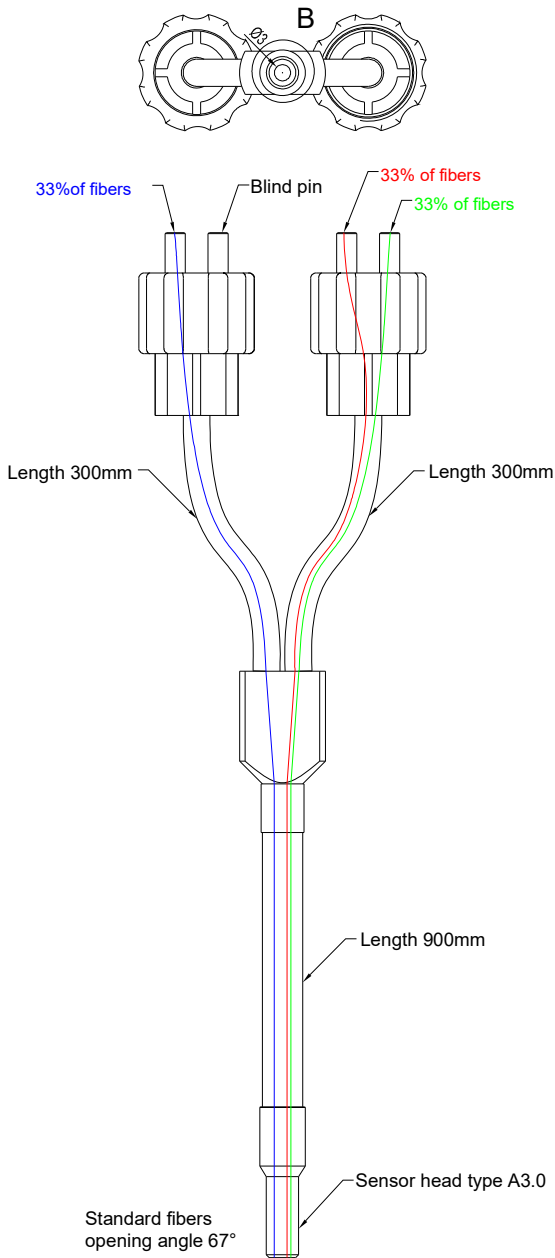
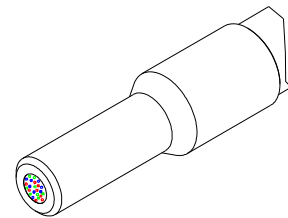

All dimensions in mm





Fiber Optics Combination

R-S-A3.0-(3.0)-1200-67° (= Transmitter fiber optics) +  
 R-S-A3.0-(3.0)-1200-67°-(1P+1BP) (= Receiver fiber optics)

R-S-A3.0-(3.0)-1200-67°-(1P+1BP)  
 (Receiver fiber optics)

R-S-A3.0-(3.0)-1200-67°  
 (Transmitter fiber optics)

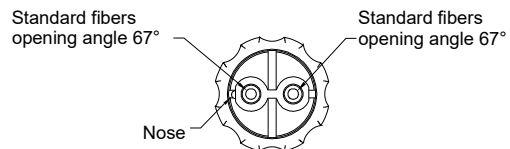
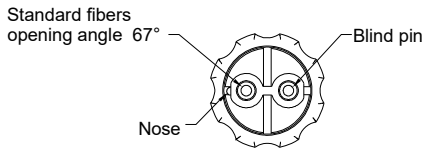
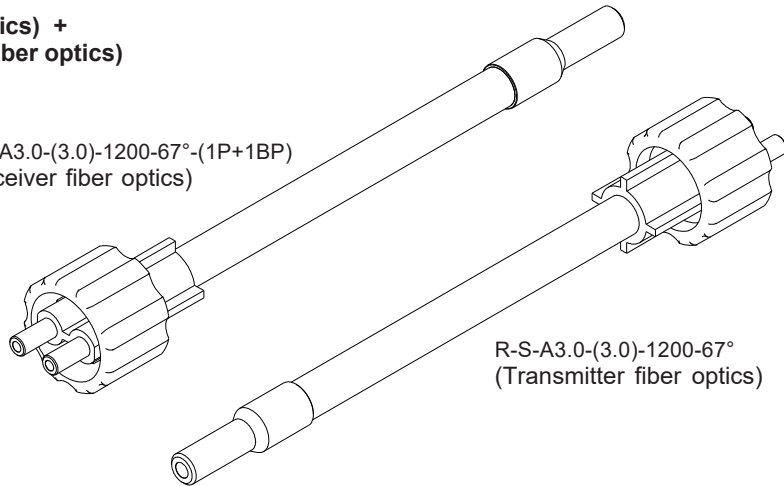

R-S-A3.0-(3.0)-1200-67°-(1P+1BP)  
 (Fiber optics special version)

R-S-A3.0-(3.0)-1200-67°  
 (Fiber optics reflected light version)

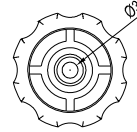
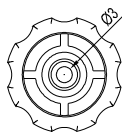
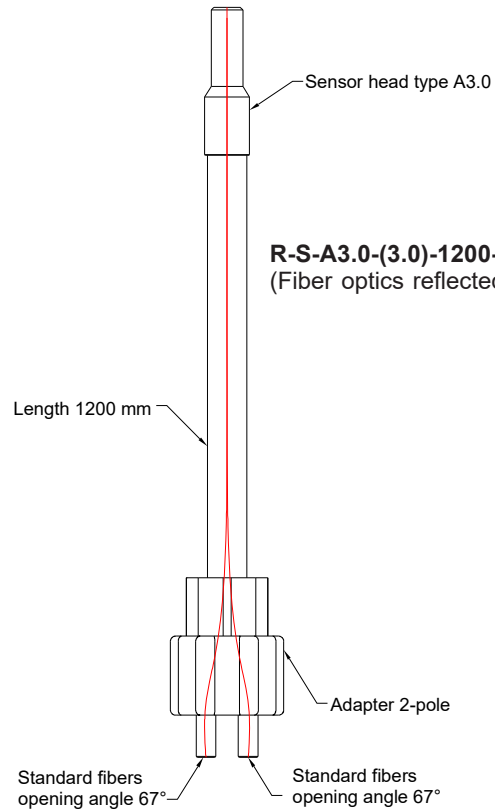
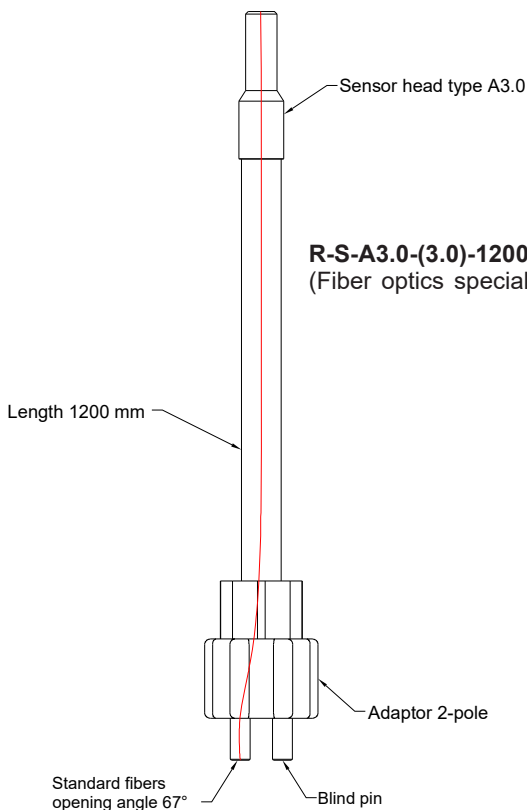

All dimensions in mm



## Optical Frontends

### Optical frontends (without fiber optics) for working distance 22 mm:

(please order fiber optics separately):

#### KL-D-0°/45°-22-d80/d110-A3.0

Optical frontend, suitable for a fiber optics combination as follows:

Transmitter fiber optics:  
R-S-A3.0-(3.0)-1200-67°

Receiver fiber optics:  
R-S-A3.0-(3.0)-1200-67°-(1P+1BP)

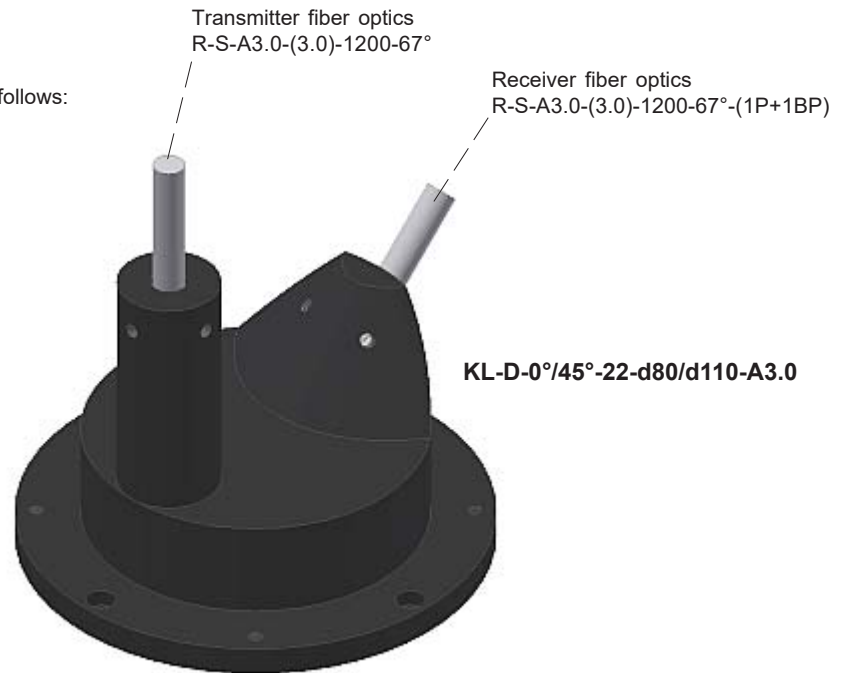

### Optical frontend with integrated fiber optics for working distance 85 mm:

(with this optical frontend the listed fiber optics are already included):

#### KL-D-0°/45°-85-1200-A3.0-VIS

Optical frontend including transmitter fiber optics and receiver fiber optics (fully assembled)

Transmitter fiber optics (integrated):  
R-S-A3.0-(3.0)-1200-67°

Receiver fiber optics (integrated):  
R-S-A3.0-(3.0)-1200-67°-(1P+1BP)

