

SPECTRO Series

▶ SPECTRO-2-FIO-(UV/VIS)/(UV/VIS)

- Suitable for the detection of fluorescent materials
- Transmitter channel 0: UV LED (375nm) / Receiver channel 0: VIS (475nm ... 1000nm)
Transmitter channel 1: UV LED (375nm) / Receiver channel 1: VIS (475nm ... 1000nm)
- Various evaluation modes available (in combination with corresponding fiber optics):
Contrast comparison (NORM),
2-channel contrast control
- Fast evaluation methods in DC-operation available (up to 130kHz)
- Insensitive to outside light (in AC-operation)
- Parameterizable via Windows® software
- RS232 interface (RS232/Ethernet converter and RS232/USB converter available)
- Suitable for use in hazardous areas (fiber optics)
- 1 analog output (0V... +10V or 4mA...20mA)
- 2 digital outputs (0V/+24V)
- External trigger input and teach input
- Linearization by means of an editable linearization curve

In Proud Partnership with Sensor Instruments

PAQUIN
SENSORS

For technical support, sales, & distribution
within the USA & Canada

www.paquin.com | (800) 831-8217 | paquinsensors@paquin.com



Design

Product name:

SPECTRO-2-FIO-(UV/VIS)/(UV/VIS)*

(incl. Windows® PC software SPECTRO2-Scope)

*2-channel system

(Transmitter channel 0/Receiver channel 0)/

(Transmitter channel 1/Receiver channel 1)

(UV/VIS)/(UV/VIS):

Transm. channel 0: UV LED (375nm) /

Receiver channel 0: VIS (475nm ... 1000nm) /

Transm. channel 1: UV LED (375nm) /

Receiver channel 1: VIS (475nm ... 1000nm)

Accessories: (p. 8-13)

Standard UV fiber optics
Special UV fiber optics
Optical frontends

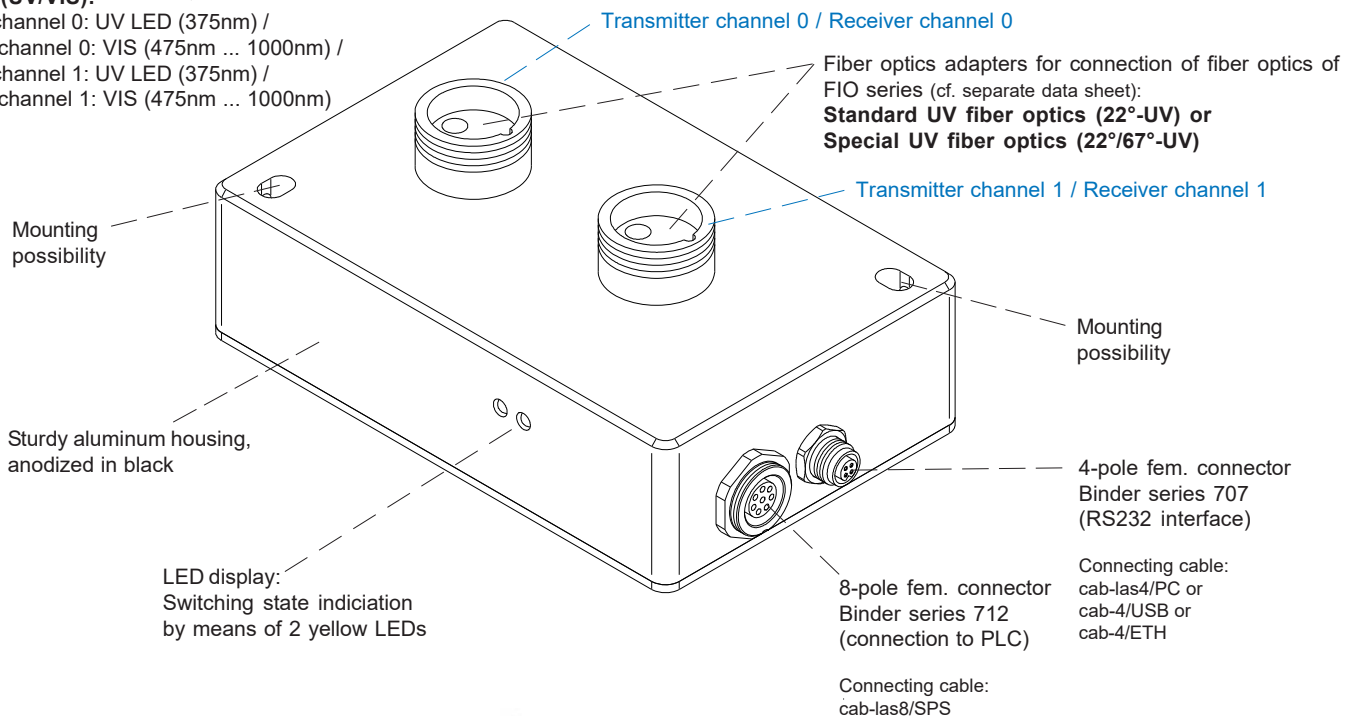



Technical Data

Model	SPECTRO-2-FIO-(UV/VIS)/(UV/VIS)																																					
Voltage supply	+24VDC (± 10%), reverse polarity protected, overcurrent protected																																					
Current consumption	< 160 mA																																					
Max. switching current	100 mA, short circuit proof																																					
Switching state indication	2 yellow LED visualize the physical state of the outputs OUT0 and OUT1																																					
Digital inputs (2x)	IN0 and IN1 (Pin 3 and 4): digital (0V/+24V)																																					
Digital outputs (2x)	OUT0 and OUT1 (Pin 5 and 6): digital (0V/+24V), npn/pnp-able (bright-/dark-switching, can be switched)																																					
Analog output (1x)	ANALOG (Pin 7): voltage 0 ... +10V or current 4 ... 20mA, adjustable via PC software																																					
Interface	RS232																																					
Pulse lengthening	0 ... 100 ms, adjustable via PC software																																					
Averaging	max. 32768 values, adjustable via PC software																																					
Scan frequency (LED mode AC or DC, can be switched via PC software)	<table style="width: 100%; border-collapse: collapse;"> <thead> <tr> <th style="width: 33%;"></th> <th colspan="3" style="text-align: left; font-weight: normal;">LED mode AC (depends on parameterization):</th> <th colspan="3" style="text-align: left; font-weight: normal;">LED mode DC (depends on parameterization):</th> </tr> <tr> <th style="font-weight: normal;">Frequency [Hz]</th> <th style="font-weight: normal;">Digital outputs</th> <th style="font-weight: normal;">Analog output</th> <th style="font-weight: normal;">Frequency [Hz]</th> <th style="font-weight: normal;">Digital outputs</th> <th style="font-weight: normal;">Analog output</th> </tr> </thead> <tbody> <tr> <td>Max. 50 000</td> <td>Off</td> <td>Off</td> <td>Max. 130 000</td> <td>Off</td> <td>Off</td> </tr> <tr> <td>Max. 48 000</td> <td>On</td> <td>Off</td> <td>Max. 100 000</td> <td>On</td> <td>Off</td> </tr> <tr> <td>Max. 42 000</td> <td>Off</td> <td>On</td> <td>Max. 85 000</td> <td>Off</td> <td>On</td> </tr> <tr> <td>Max. 41 000</td> <td>On</td> <td>On</td> <td>Max. 72 500</td> <td>On</td> <td>On</td> </tr> </tbody> </table> <p>Measurements were made with the smallest gain at the receiver (AMP1). At the highest gain (AMP8), the frequency is reduced by a factor of 10.</p> <p>The frequency is independent of the gain set at the receiver.</p>		LED mode AC (depends on parameterization):			LED mode DC (depends on parameterization):			Frequency [Hz]	Digital outputs	Analog output	Frequency [Hz]	Digital outputs	Analog output	Max. 50 000	Off	Off	Max. 130 000	Off	Off	Max. 48 000	On	Off	Max. 100 000	On	Off	Max. 42 000	Off	On	Max. 85 000	Off	On	Max. 41 000	On	On	Max. 72 500	On	On
	LED mode AC (depends on parameterization):			LED mode DC (depends on parameterization):																																		
Frequency [Hz]	Digital outputs	Analog output	Frequency [Hz]	Digital outputs	Analog output																																	
Max. 50 000	Off	Off	Max. 130 000	Off	Off																																	
Max. 48 000	On	Off	Max. 100 000	On	Off																																	
Max. 42 000	Off	On	Max. 85 000	Off	On																																	
Max. 41 000	On	On	Max. 72 500	On	On																																	
Switching frequency	typ. 60 kHz																																					
Analog band width	typ. 90 kHz (-3 dB)																																					
Transmitter (light source)	Transmitter channel 0: UV-LED (375 nm) Transmitter channel 1: UV-LED (375 nm)																																					
Receiver	Receiver channel 0: Photo diode with IR filter (475 nm ... 1000 nm) Receiver channel 1: Photo diode with IR filter (475 nm ... 1000 nm)																																					
Transmitter control	can be switched via PC software: AC operation (LED MODE-AC), DC operation (LED MODE-DC)																																					
Object distance (measurement range)	with reflected light fiber optics: typ. 1 mm ... 100 mm (depends on fiber optics and attachment optics) with transmitted light fiber optics: typ. 10 mm ... 200 mm (depends on fiber optics and attachment optics)																																					
Receiver gain setting	8 steps (AMP1 ... AMP8), adjustable via PC software																																					
Ambient light	max. 5000 Lux																																					
Size of light spot	depends on fiber optics and attachment optics (cf. catalog FIO series)																																					
Reproducibility	2 digits at 12-bit A/D conversion																																					
Housing dimensions	LxWxH approx. 100 mm x 65 mm x 38 mm (incl. fiber optics connector M18x1, without connectors)																																					
Housing material	aluminum, anodized in black																																					
Enclosure rating	IP64																																					
Connecting cables	to PLC: cab-las8/SPS or cab-las8/SPS-w to PC/RS232 interface: cab-las4/PC or cab-las4/PC-w to PC/USB interface: cab-4/USB or cab-4/USB-w to PC/Ethernet interface: cab-4/ETH																																					
Type of connector	connection to PLC: 8-pole fem. connector (Binder 712) connection to PC: 4-pole fem. connector (Binder 707)																																					
Operating temp. range	-20°C ... +55°C																																					
Storage temp. range	-20°C ... +85°C																																					
EMC test acc. to	DIN EN 60947-5-2																																					

Dimensions

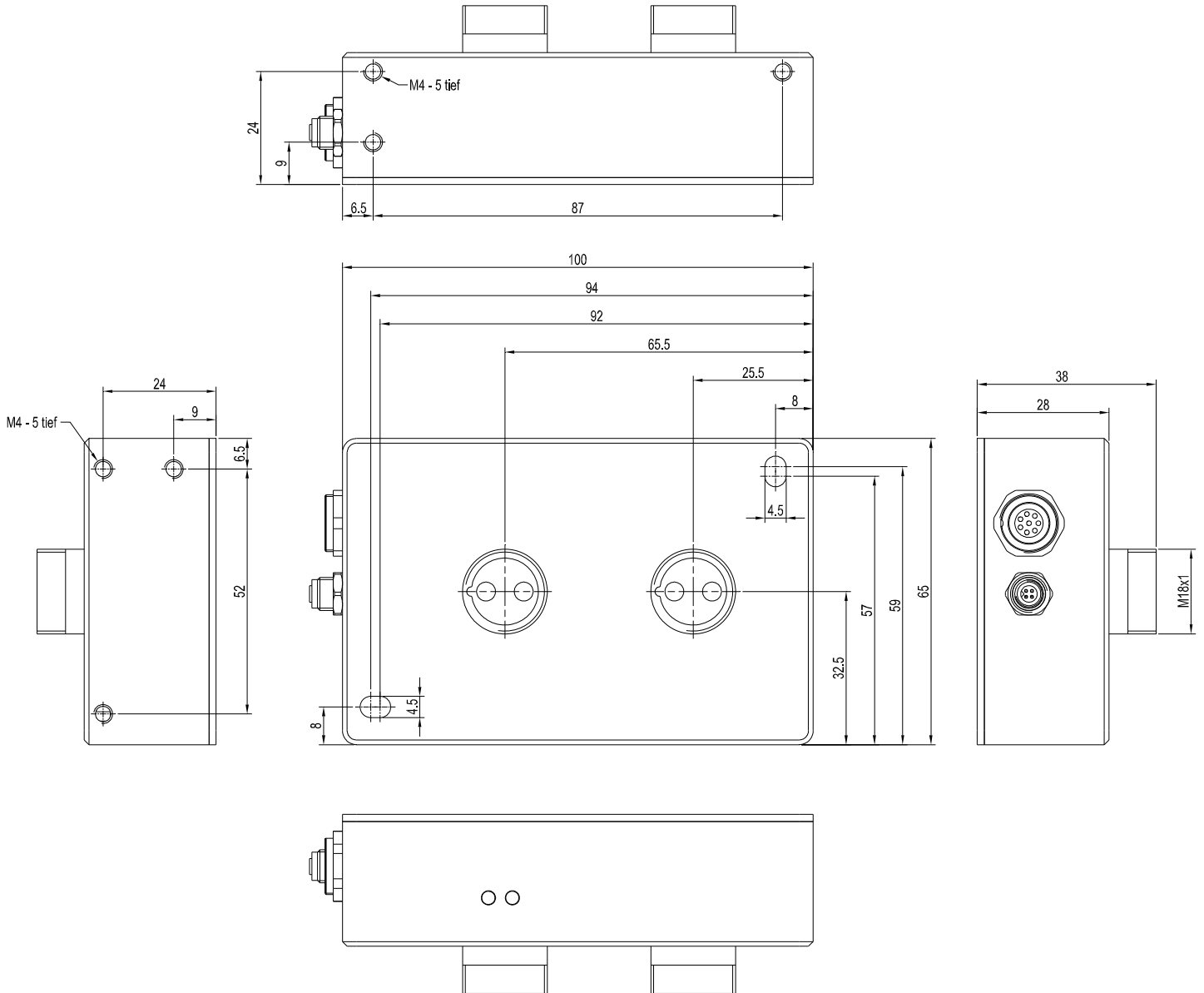

All dimensions in mm

Connector Assignment

Connection to PLC:**8-pole fem. connector Binder Series 712**

Pin:	Color:	Assignment:
1	white	GND (0V)
2	brown	+24VDC ($\pm 10\%$)
3	green	IN0 (Digital 0: 0 ... 1V, Digital 1: +Ub - 10%)
4	yellow	IN1 (Digital 0: 0 ... 1V, Digital 1: +Ub - 10%)
5	grey	OUT0 (Digital 0: Type 0 ... 1V, Digital 1: Type +Ub - 10%)
6	pink	OUT1 (Digital 0: Type 0 ... 1V, Digital 1: Type +Ub - 10%)
7	blue	ANALOG (0 ... +10V or 4 ... 20mA)
8	red	n.c.

Connecting cable:

cab-las8/SPS-(length)

cab-las8/SPS-w-(length) (angle type, 90°)

(standard length 2m)

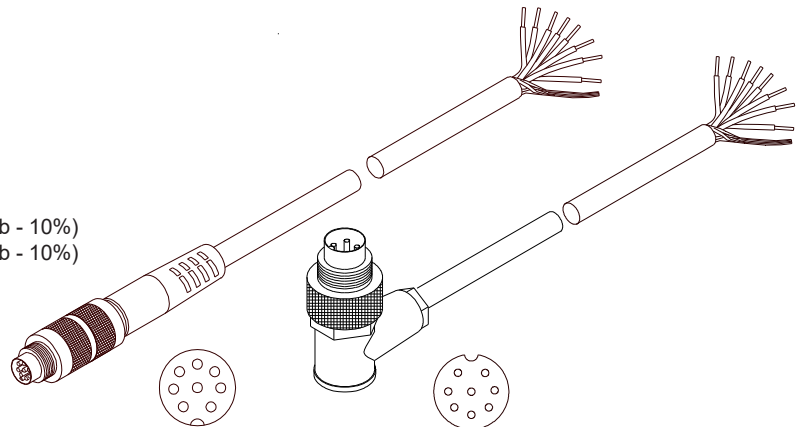
cab-las8/SPS-...
(max. length 25m,
outer jacket: PUR)cab-las8/SPS-w-...
(max. length 25m,
outer jacket: PUR)**Connection to PC:****4-pole fem. connector Binder Series 707**

Pin:	Assignment:
1	+24VDC (+Ub, OUT)
2	GND (0V)
3	RxD
4	TxD

Connection via RS232 interface at the PC:**Connecting cable:**

cab-las4/PC-(length)

cab-las4/PC-w-(length) (angle type 90°)

(standard length 2m)

alternative:**Connection via USB interface at the PC:**

USB converter (incl. driver software):

cab-4/USB-(length)

cab-4/USB-w-(length) (angle type 90°)

(standard length 2m)

alternative:**Connection to local network via Ethernet bus:**

Ethernet converter (incl. software „SensorFinder“):

cab-4/ETH-500

(standard length 0.5m)

Optional: External CAT5 cable, e.g.

cab-eth/M12D-RJ45-flx-(length)

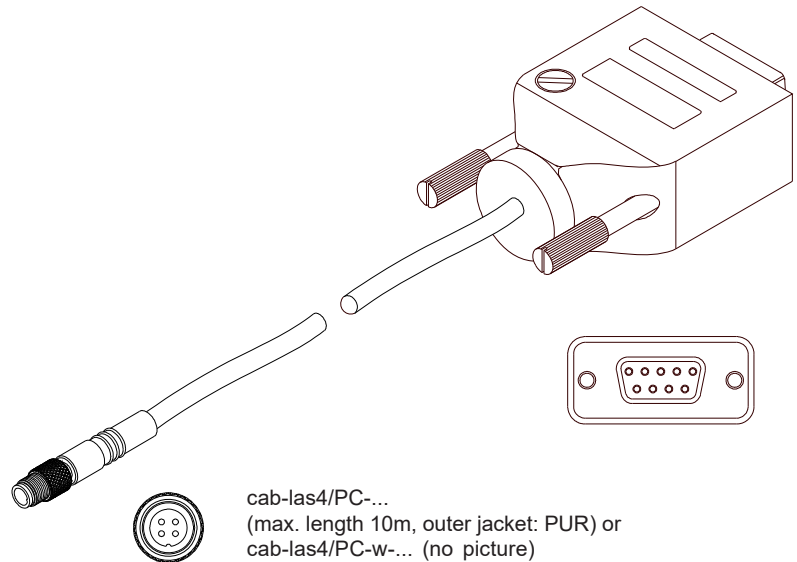
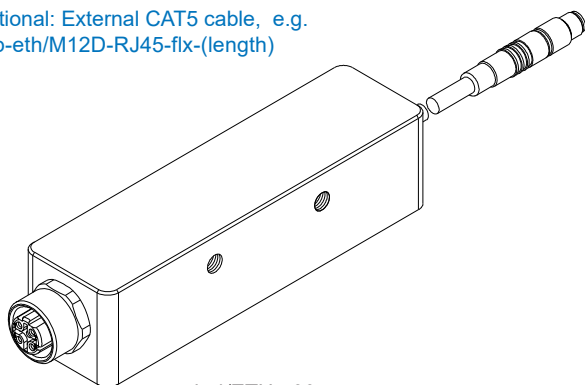
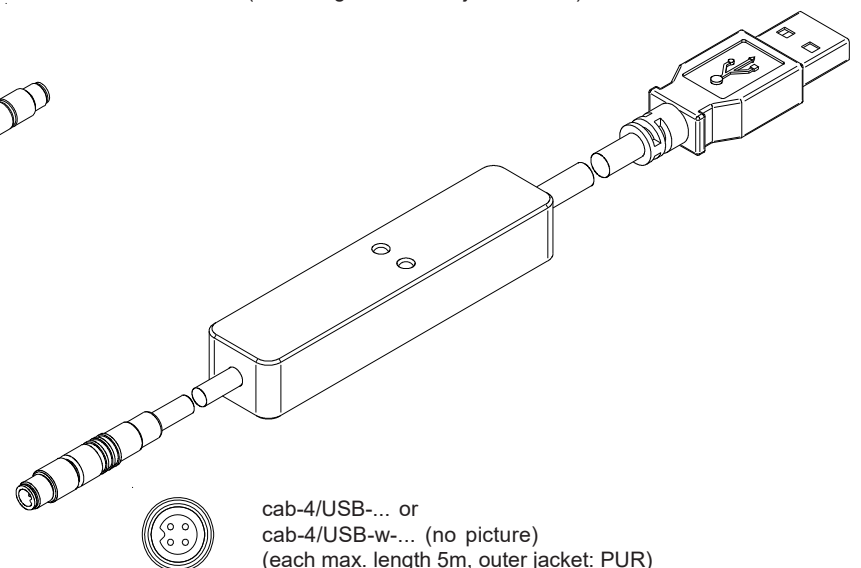
cab-las4/PC-...
(max. length 10m, outer jacket: PUR) or
cab-las4/PC-w-... (no picture)
(max. length 5m, outer jacket: PUR)cab-4/ETH-500
(length 0.5m, outer jacket: PUR)
4-pole M12 fem. conn. (D-coded)
for connection of an external
CAT5 cable, e.g.
cab-eth/M12D-RJ45-flx-(length)cab-4/USB-... or
cab-4/USB-w-... (no picture)
(each max. length 5m, outer jacket: PUR)



LED Display

LED display:

By means of the two LEDs the physical state of the two outputs OUT0 and OUT1 is visualized:

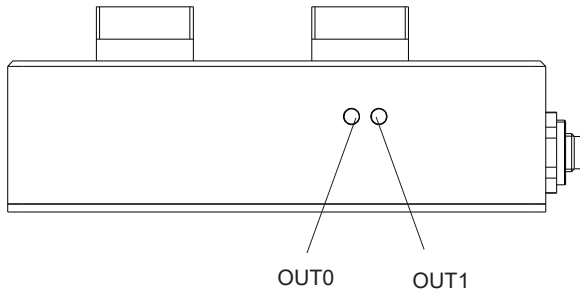

Measuring Principle

Measuring principle of the sensors of SPECTRO-2 series:

The sensors of the SPECTRO-2 series feature a two-channel design, which means they acquire the analog signals of two receivers and evaluate these signals. They also have two independently adjustable transmitter sources. Various light sources such as e.g. white light, UV light, or IR light, are available as transmitters. The receiver is correspondingly matched to the transmitter. The acquired analog signal is provided through a voltage output or a current output.

The software can be used to select various evaluation modes for the analog signal.

The status of the output signal is provided through 2 digital outputs in accordance with the selected evaluation mode.

A digital input allows external "teaching" of the sensor.

An additional input allows the "freezing" of the analog output signal upon a positive input edge.

The SPECTRO-2 sensor allows highly flexible signal acquisition. The sensor, for example, can be operated in alternating-light mode (AC mode), which means the sensor is not influenced by external light, or in constant-light mode (DC mode), which provides outstanding high-speed sensor operation. An OFF function deactivates the sensor's integrated light source and changes to DC mode, which allows the sensor to detect so-called "self-luminous objects". With the stepless adjustment of the integrated light source, the selectable gain of the receiver signal, and an INTEGRAL function the sensor can be adjusted to almost any surface or any "self-luminous object".

A micro-controller performs 12-bit analog/digital conversion of the analog signal, which allows recording and evaluation of the signal. Furthermore the SPECTRO-2 sensor offers various options for intelligent signal processing such as e.g. dirt accumulation compensation.

Parameters and measurement values can be exchanged between PC and sensor either through RS232 or Ethernet (using an Ethernet converter). Through the interface all the parameters can be stored in the non-volatile EEPROM of the sensor.

The PC software facilitates the parameterisation, diagnostics, and adjustment of the sensor system (oscilloscope function). The software furthermore provides a data recorder function that automatically records data and stores them on the hard disk of the PC.

SPECTRO-2 sensors are temperature-compensated over a range of 0°C to 80°C.

When parameterisation is finished, the sensor continues to operate with the current parameters in STAND-ALONE mode without a PC.



Parameterization

Windows® user interface:

(The current software version is available for download on our website.)

The PC software SPECTRO2-Scope facilitates the parameterization, the diagnosis, and the adjustment of the sensor system (oscilloscope function). Moreover, the software features a data recorder function that allows the automatic recording of recorded data and the saving of those at the hard disk of the PC.

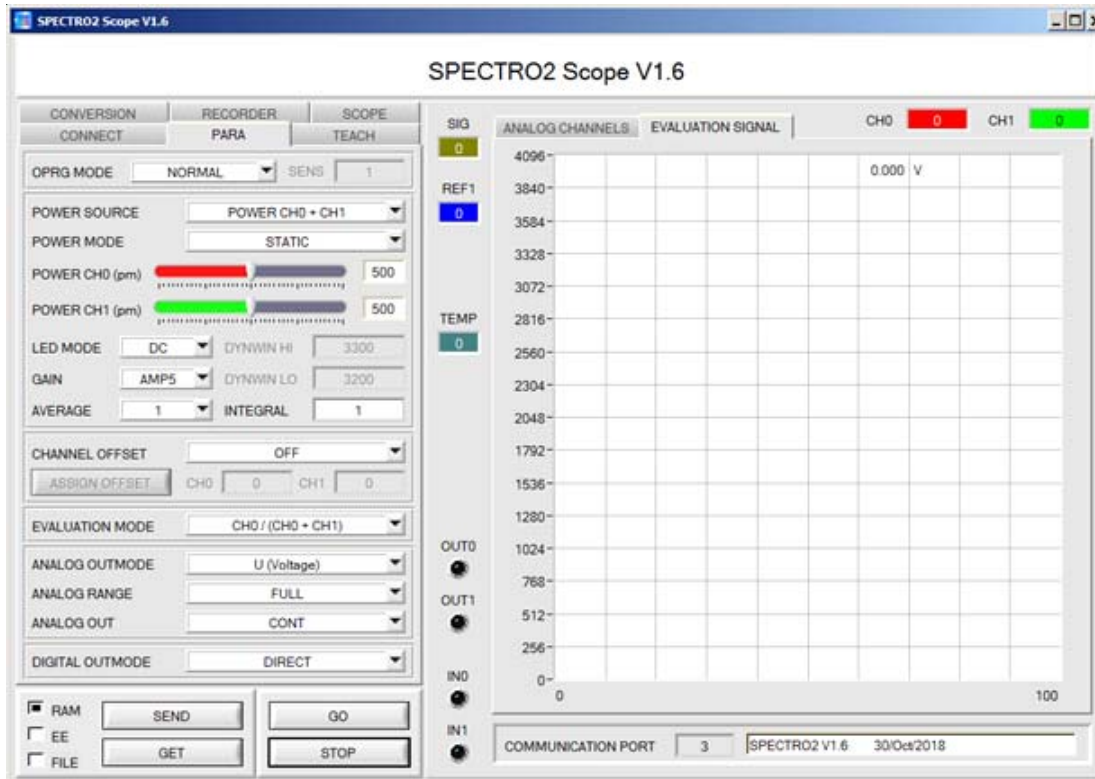

Parameters and measurement values can be exchanged between PC and sensor either through RS232 or Ethernet (using the Ethernet converter cab-4/ETH-500).

Through the interface all the parameters can be stored in the non-volatile EEPROM of the sensor.



The SCOPE tab visualizes an oscilloscope.



Firmware Update

Firmware update by means of the software „FirmwareLoader“:

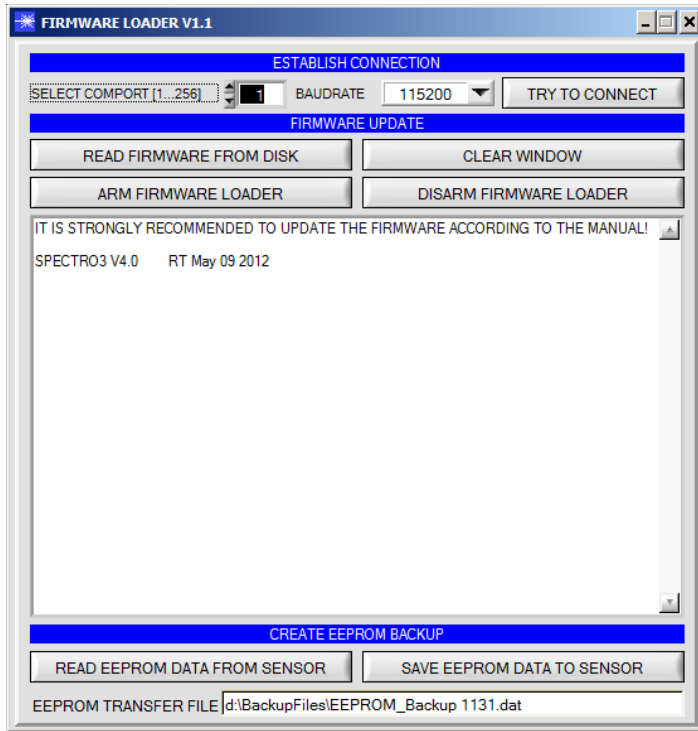

The software „Firmware Loader“ allows the user to perform an automatic firmware update. The update will be carried out through the RS232 interface.

An initialisation file (xxx.ini) and a firmware file (xxx.elf.S) are required for performing a firmware update. These files can be obtained from your supplier. In some cases an additional firmware file for the program memory (xxx.elf.p.S) is also needed, and this file will be automatically provided together with the other two files.



UV Fiber Optics

Available standard UV fiber optics:

- R-S-A1.1-(1.5)-1200-22°-UV
- R-S-A2.0-(2.5)-600-22°-UV
- R-S-A2.0-(2.5)-1200-22°-UV
- R-S-A3.0-(3.0)-1200-22°-UV
- R-S-R1.1-(3x0.5)-600-22°-UV
- R-S-R1.1-(3x0.5)-1200-22°-UV
- R-S-R2.1-(6x1)-1200-22°-UV
- D-P-B3.0-(2.5)-600-22°-UV
- D-S-A2.0-(2.5)-600-22°-UV
- D-S-A3.0-(3.0)-600-22°-UV

Available special UV fiber optics (p. 9-12)

- R-S-A3.0-(3.0)-1200-22°/67°-UV
- R-S-R2.1-(6x1)-1200-22°/67°-UV
- D-S-A3.0-(3.0)-1200-22°/67°-UV
- D-S-R2.1-(6x1)-1200-22°/67°-UV

(further fiber optics types are available on request)



Characteristics:

Light-conducting glass fibers are optical components that allow the transmission of light through any curved path based on the principle of total reflection. The individual fiber is composed of high-break core glass and low-break cladding glass. The light beams entering the core glass within the critical angle are guided through the fiber by way of reflection at the core/cladding contact surfaces (step index fiber). The highly flexible optical fibers are made of bundled individual glass fibers. The ends are each glued into a sensor head and a connector. The faces are optically polished. For protection against mechanical, chemical, or thermal destruction the optical fibers are provided with a corresponding protective sheath.

Order code:

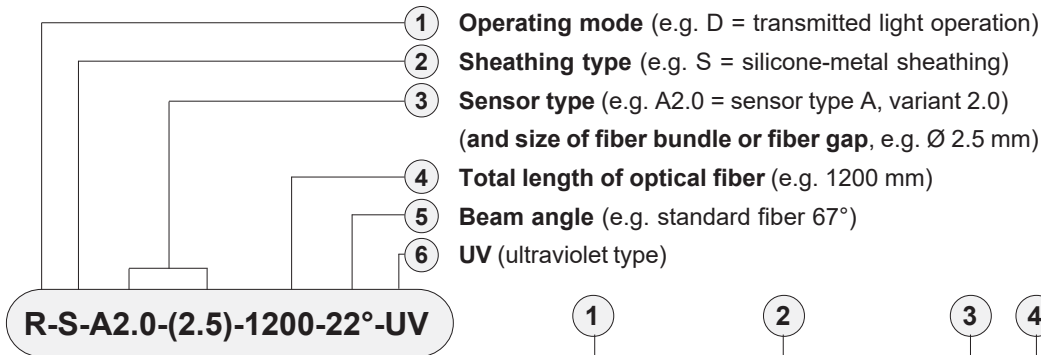

R-S-A2.0-(2.5)-1200-22°-UV

Order code for optical fiber

(For detailed description of the various types of fiber optics, please cf. catalog „FIO Series“)

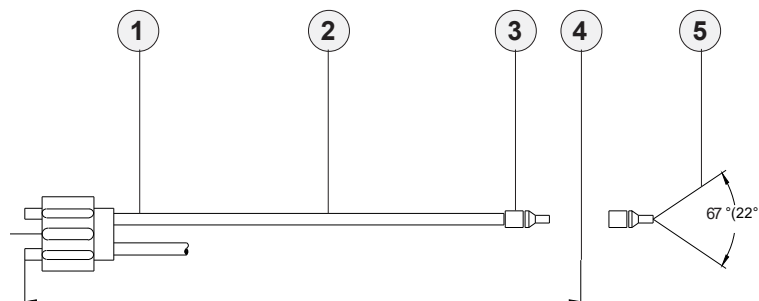

Dimensions of adapter

Attachment optics (e.g. focus lens, reflex optics, prismn optics)

Fiber optics for reflex light operation

Fiber optics for transmitted light operation

Mounting hints

cf. catalog FIO Series

cf. catalog FIO Series

cf. catalog FIO Series

cf. catalog FIO Series

cf. catalog FIO Series



Spezial UV Fiber Optics

R-S-A3.0-(3.0)-1200-22°/67°-UV
Reflected-light UV fiber optics

Detail B

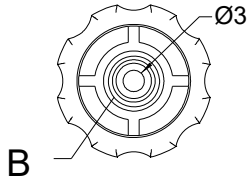
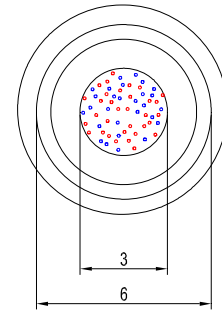

Adapter 2-pin

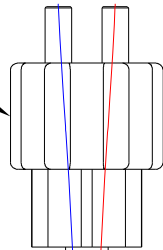

Length
1200mm

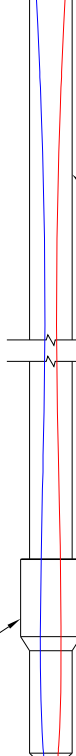

Sensor head type
A3.0 (3.0)

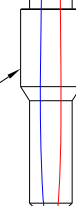

Detail A

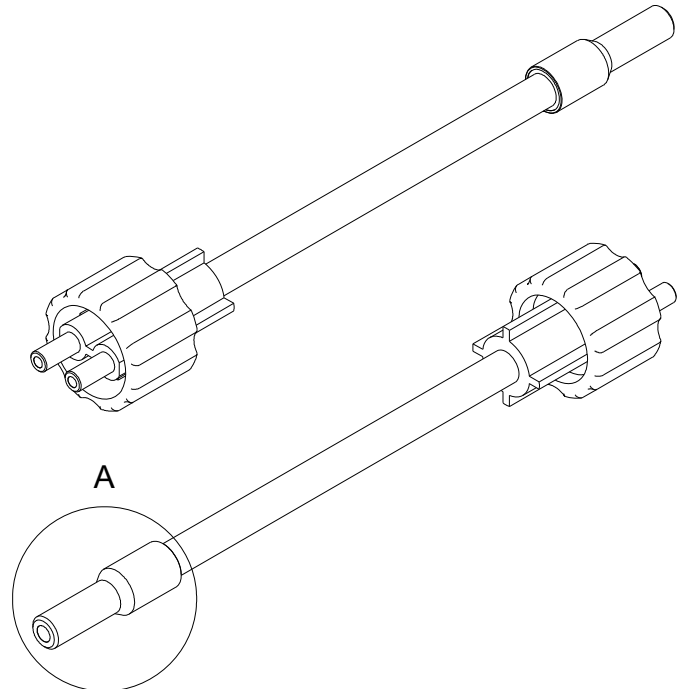
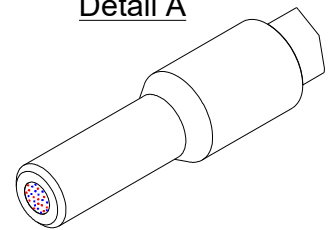

A

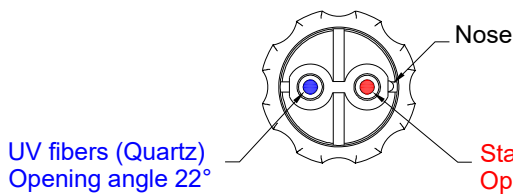

UV fibers (Quartz)
Opening angle 22°

Standard fibers
Opening angle 67°

Special UV Fiber Optics

R-S-R2.1-(6x1)-1200-22°/67°-UV
Reflected light UV fiber optics

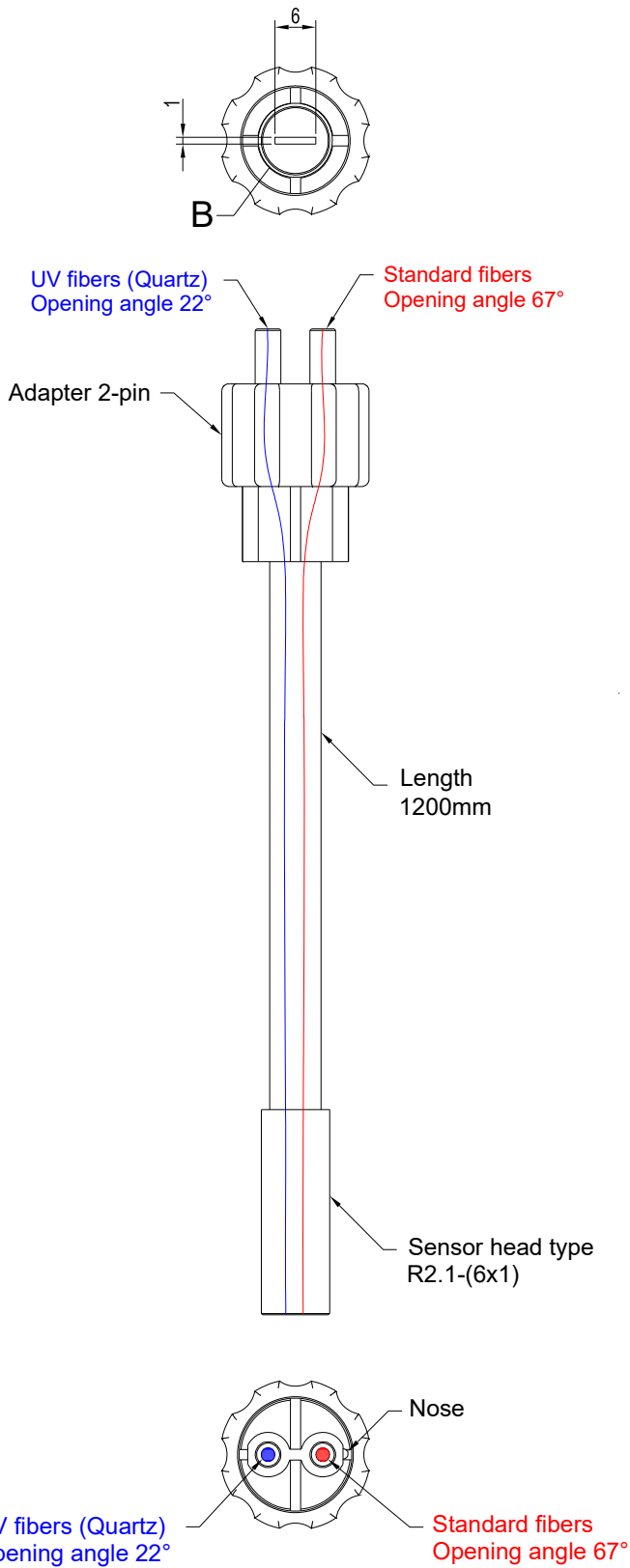

Detail B

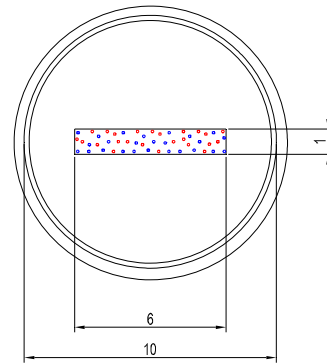

Detail A

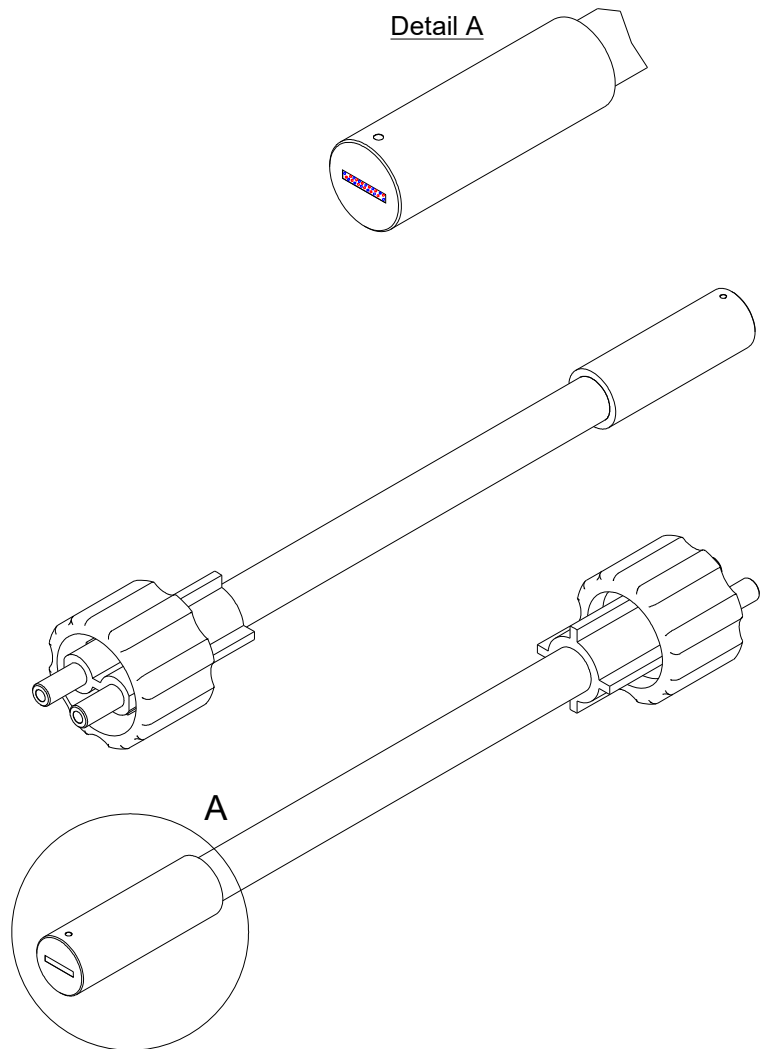

Spezial UV Fiber Optics

D-S-A3.0-(3.0)-1200-22°/67°-UV
Transmitted-light UV fiber optics

Detail

Detail

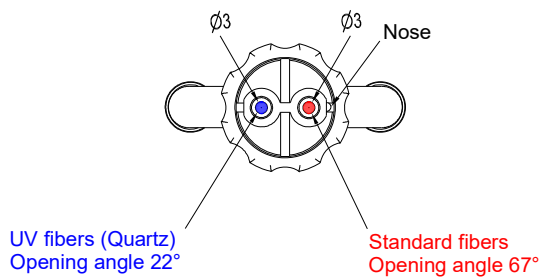
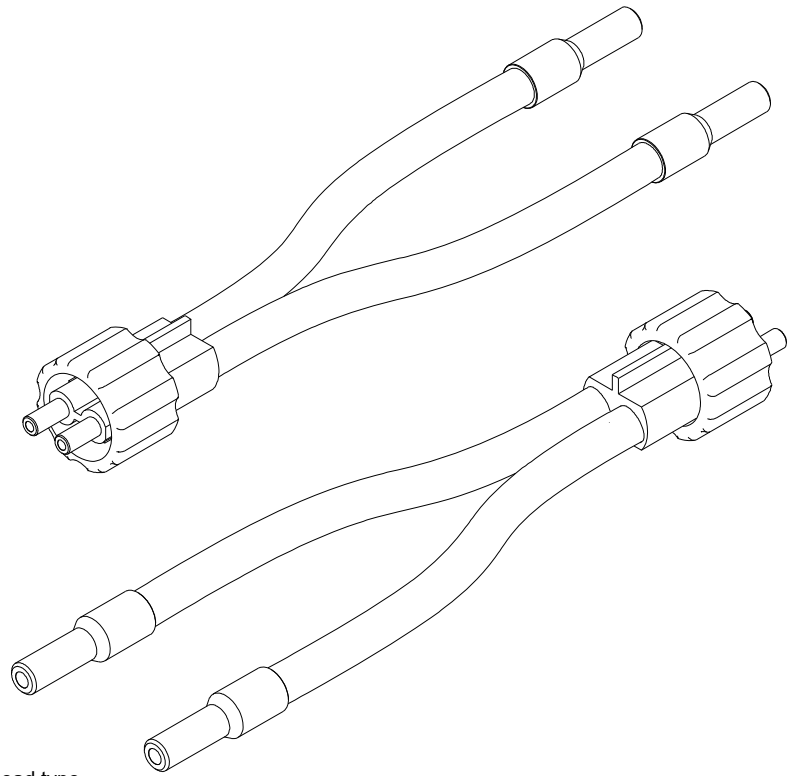
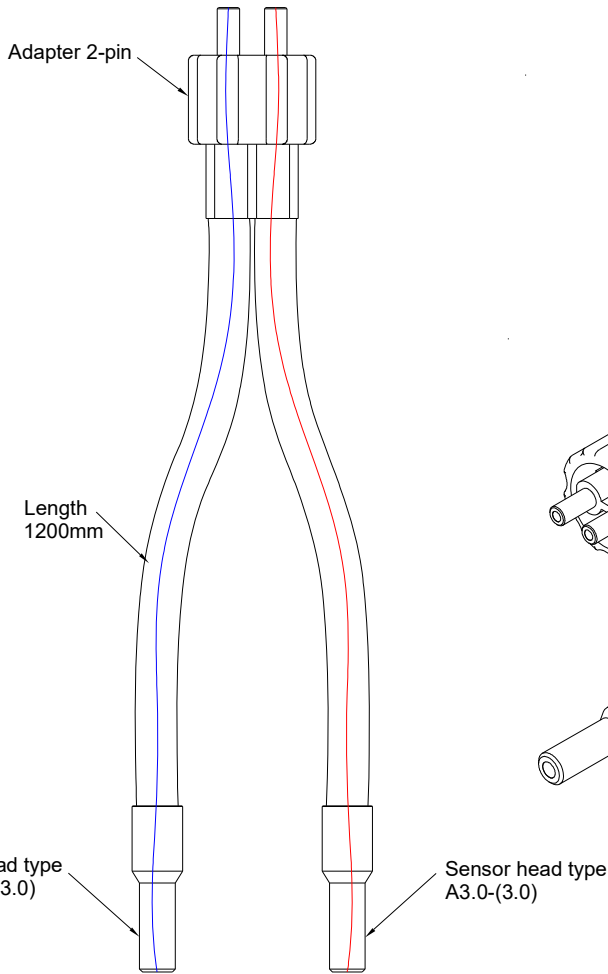
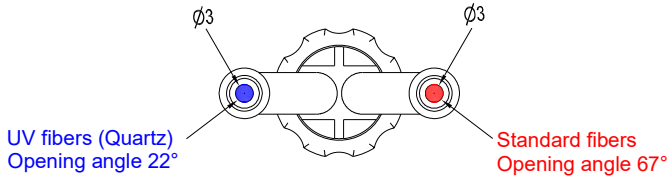
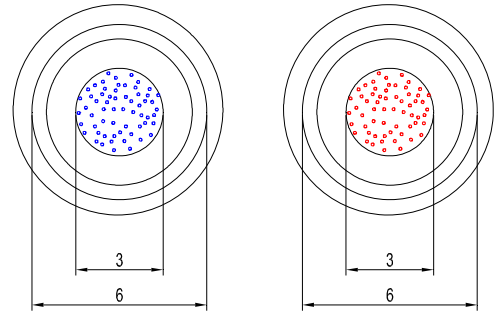



Spezial UV Fiber Optics

D-S-R2.1-(6x1)-1200-22°/67°-UV
Transmitted-light UV fiber optics

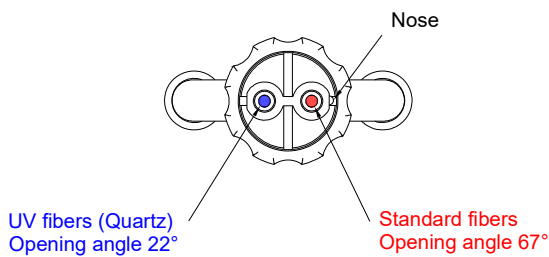
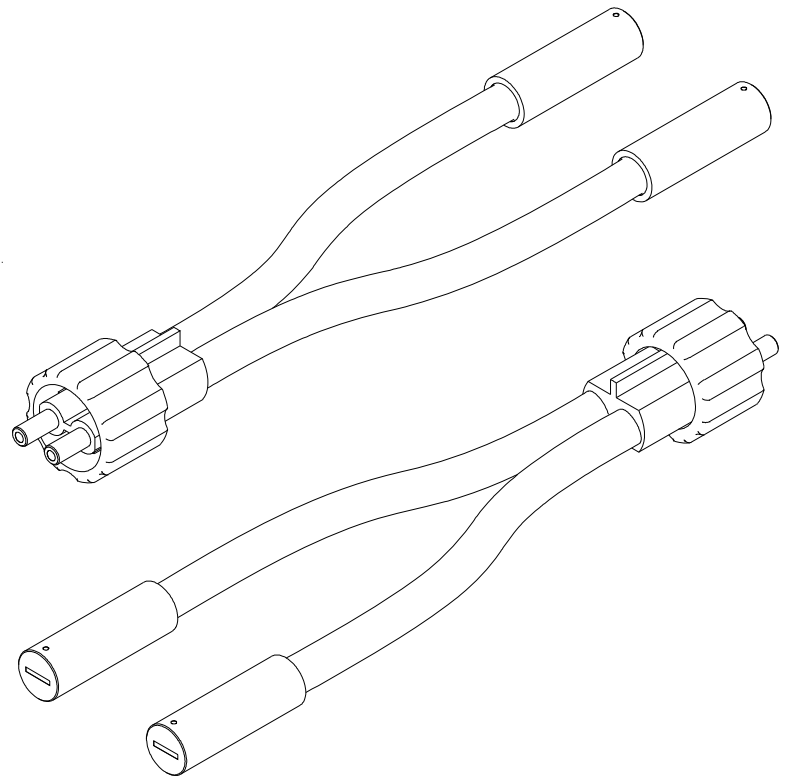
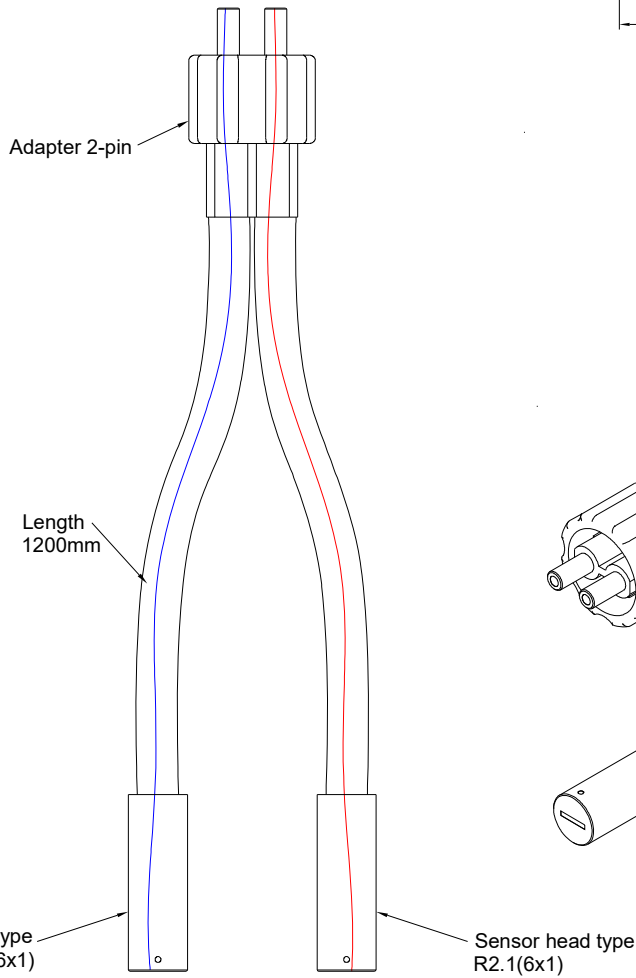
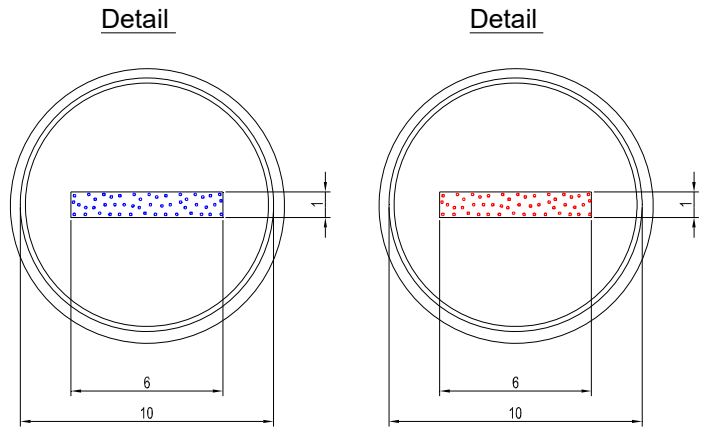
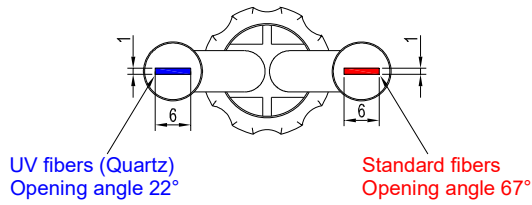



Optical Frontends

Overview: Optical frontends for UV fiber optics with sensor head type „A3.0“ or „R2.1“:



KL-8-R2.1
KL-9-A3.0



KL-M12-A3.0



KL-M18-A3.0
KL-M18-R2.1



KL-M18-XL-A3.0
KL-M18-XL-R2.1



KL-M34-A3.0
KL-M34-R2.1



KL-M34-XL-A3.0
KL-M34-XL-R2.1



KL-M34/62-A3.0
KL-M34/62-R2.1



KL-52-XL-A3.0



KL-D-10°-45-POL°-A3.0

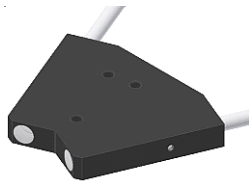

KL-D-0°/45°-30-A3.0



KL-D-5°-85-POL-A3.0

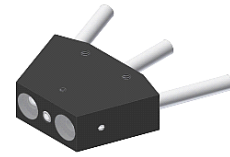

KL-D-40°-23-5/DIF-A3.0



KL-D-20°-20-POL-A3.0



KL-D-M12-0°/30°-9-A3.0

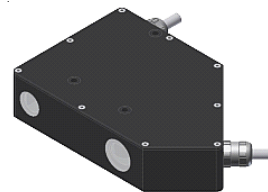

KL-D-0°/45°-85-1200-A3.0