

SPECTRO-M Series

► SPECTRO-M-2-15-3.5/4.25

- Inline sensor for non-contact measurement of thin organic coatings on metal substrates in diffuse reflection
- Measurement in the mid-infrared range (MIR)
- Working distance typ. 13 mm ... 17 mm
- 1 analog output (voltage 0V...+10V or current 4mA...20mA)
- 2 digital outputs (0V/+24V)
- 2 digital inputs (0V/+24V)
- Data interface (RS232)
- Ethernet converter available
- Windows® PC software for sensor parameterization
- On-site calibration to the respective metal surface and the medium to be measured
- Output of the coating in various units: thickness [µm], surface tension [mN/m], weight [g/m²] or RFU via data interface
- Temperature compensation for ambient temperatures from 10°C to 45°C
- Sturdy sensor in an anodized aluminum housing, CaF glass covers and integrated evaluation electronics
- No moving parts, insensitive to vibrations

In Proud Partnership with Sensor Instruments

PAQUIN
SENSORS

For technical support, sales, & distribution
within the USA & Canada

www.paquin.com | (800) 831-8217 | paquinsensors@paquin.com



Design

Product name:

SPECTRO-M-2-15-3.5/4.25

(incl. Windows® software SPECTRO-M-2-Scope)

Accessories: (page 8)

SPECTRO-M-2-15-OFL

(Spacer)

Sturdy aluminum housing,
anodized in black

Optics holder (aluminum,
anodized in black or
natural anodized)

Transmitter optics
with 8 MIR light
sources

Receiver optics with
5 band-pass filters each
for the two MIR measuring
windows

4-pole fem.
connector
Binder series 707
(RS232 interface)

Connecting cable:
cab-las4/PC or
cab-4/USB or
cab-4/ETH

8-pole fem. connector
Binder series 712
(Connection to PLC)

Connecting cable:
cab-las8/SPS

LED display:
Switching state
indication by means of
2 yellow LED

Mounting screws
(M34)





Technical Data

Type	SPECTRO-M-2-15-3.5/4.25															
Voltage supply	+24VDC (± 10%), reverse polarity protected, overcurrent protected															
Current consumption	typ. 300mA															
LED display	2 yellow LED on the front of the housing visualize the physical state of the outputs OUT0 and OUT1															
Inputs digital (2x)	IN0 (Pin 3) and IN1 (Pin 4): digital (0V/+24V)															
Outputs digital (2x)	OUT0 (Pin 5) and OUT1 (Pin 6): digital (0V/+24V) npn-/pnp-able (bright-/dark-switching, can be switched)															
Output analog (1x)	ANALOG (Pin 8): Voltage (0...+10V) or current (4mA...20mA)															
Interface	RS232															
Pulse lengthening	0 ... 100 ms, adjustable via PC software															
Averaging	max. 32768 values, adjustable via PC software															
Scan frequency	Depending on the parameterization: <table style="margin-left: 20px; border-collapse: collapse;"> <thead> <tr> <th>Frequency [Hz]</th> <th>Digital outputs</th> <th>Analog output</th> </tr> </thead> <tbody> <tr> <td>Max. 85 000</td> <td>Off</td> <td>Off</td> </tr> <tr> <td>Max. 71 000</td> <td>On</td> <td>Off</td> </tr> <tr> <td>Max. 57 500</td> <td>Off</td> <td>On</td> </tr> <tr> <td>Max. 50 000</td> <td>On</td> <td>On</td> </tr> </tbody> </table> Accurate display on the PC interface	Frequency [Hz]	Digital outputs	Analog output	Max. 85 000	Off	Off	Max. 71 000	On	Off	Max. 57 500	Off	On	Max. 50 000	On	On
Frequency [Hz]	Digital outputs	Analog output														
Max. 85 000	Off	Off														
Max. 71 000	On	Off														
Max. 57 500	Off	On														
Max. 50 000	On	On														
Switching frequency	typ. 60 kHz															
Analog band width	typ. 90 kHz (-3dB)															
Object distance	typ. 13 mm ... 17 mm															
Receiver	2-channel-receiver, each channel with 5 receivers (Measuring window central wavelength: 3.5 µm and 4.25 µm)															
Transmitter	High-power MIR transmitter															
Spot size	typ. Ø 25 mm at a working distance of 15 mm															
Reproducibility	± 2 digit at 12-Bit-A/D-conversion															
Housing dimensions	Length approx. 144.5 mm x Ø 32 mm respectively M34 (optics holder approx. Ø 81 mm)															
Housing material	Aluminum, anodized in black (optics holder natural anodized)															
Enclosure rating	IP64															
Type of connector	Connection to PLC: 8-pole fem. connector (Binder 712) Connection to PC: 4-pole fem. connector (Binder 707)															
Connecting cables	to PLC: cab-las8/SPS or cab-las8/SPS-w to PC/RS232-interface: cab-las4/PC or cab-las4/PC-w to PC/USB-interface: cab-4/USB or cab-4/USB-w to PC/Ethernet-interface: cab-4/ETH															
Warm-up time	The sensor requires approx. 45 minutes to reach a temperature equilibrium with the environment and thus ensure the stability of the measured value															
Operating temperature range	+0°C ... +50°C															
EMC test acc. to	DIN EN 60947-5-2															



Dimensions

SPECTRO-M-2-15-3.5/4.25

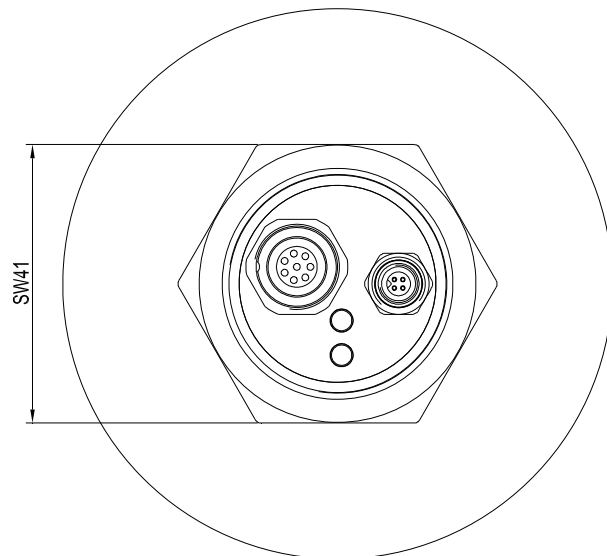
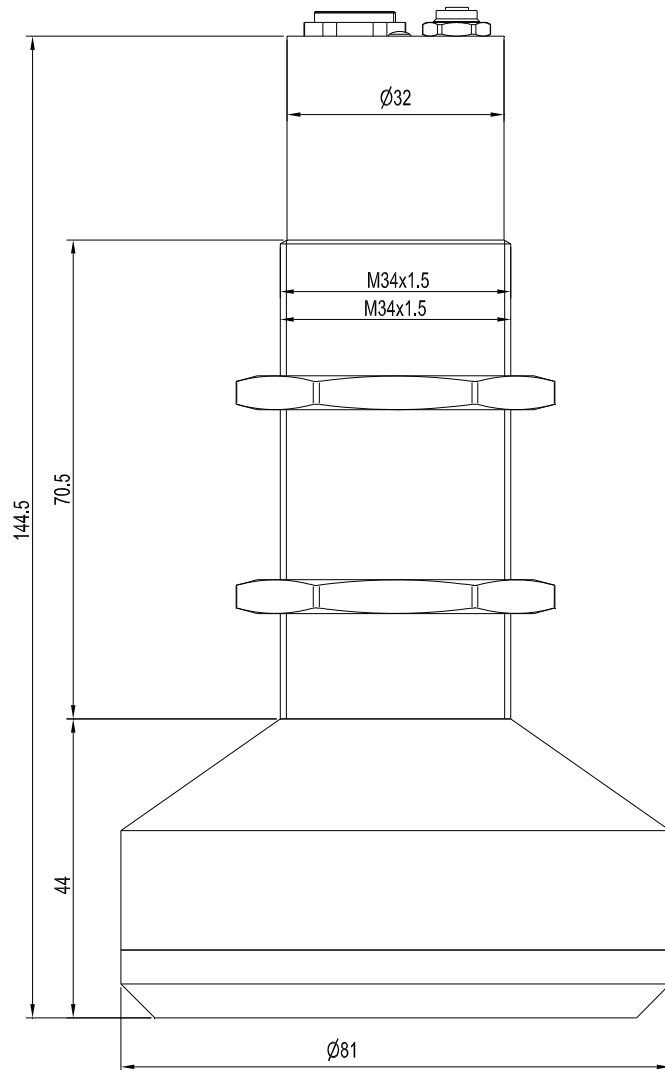

All dimensions in mm

Anschlussbelegung

Connection to PLC:
8-pole fem. connector Binder series 712

Pin:	Color:	Assignment:
1	white	GND (0V)
2	brown	+24VDC ($\pm 10\%$)
3	green	IN0 (Digital 0: 0 ... 1V, Digital 1: +Ub - 10%)
4	yellow	IN1 (Digital 0: 0 ... 1V, Digital 1: +Ub - 10%)
5	grey	OUT0 (Digital 0: Type 0 ... 1V, Digital 1: Type +Ub - 10%)
6	pink or black	OUT1 (Digital 0: Type 0 ... 1V, Digital 1: Type +Ub - 10%)
7	blue	not connected
8	red	ANALOG (0 ... +10V or 4 ... 20mA)

Connecting cable:
 cab-las8/SPS-(length)
 cab-las8/SPS-w-(length)
 (standard length 2m)

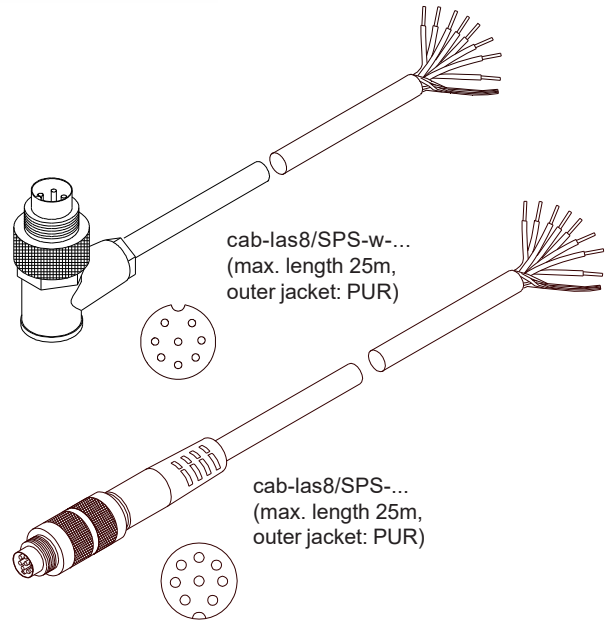

Connection to PC:
4-pole fem. connector Binder Series 707

Pin:	Assignment:
1	+24VDC (+Ub, OUT)
2	GND (0V)
3	RxD
4	TxD

Connection via RS232 interface at the PC:

Connecting cable:
 cab-las4/PC-(length)
 cab-las4/PC-w-(length) (angle type 90°)
 (standard length 2m)

alternative:

Connection via USB interface at the PC:

USB converter (incl. driver software):
 cab-4/USB-(length)
 cab-4/USB-w-(length) (angle type 90°)
 (standard length 2m)

alternative:

Connection to local network via Ethernet bus:

Ethernet converter (incl. software „SensorFinder“):
 cab-4/ETH-500
 (standard length 0.5m)

Optional: External CAT5 cable, e.g.
 cab-eth/M12D-RJ45-flx-(length)

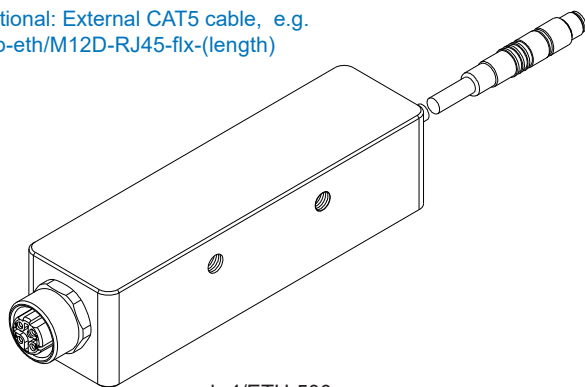
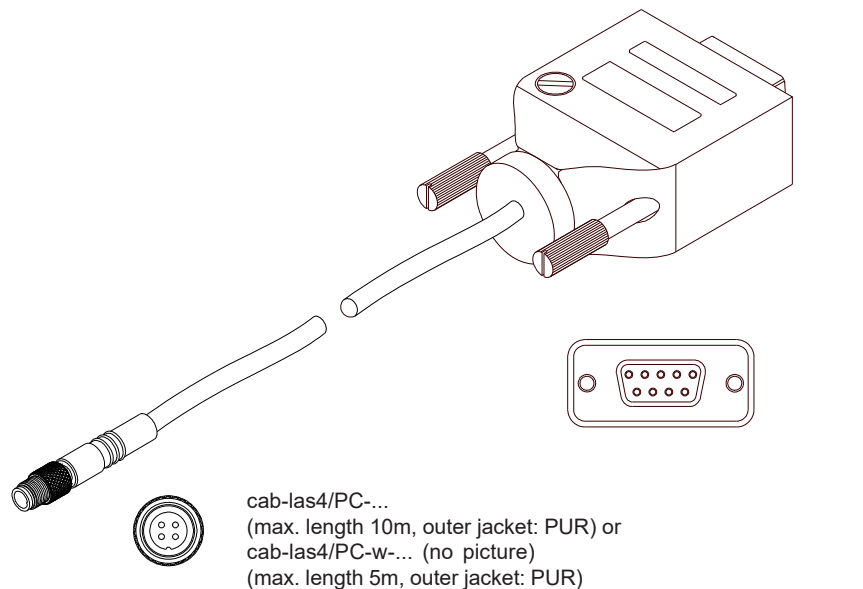

cab-4/ETH-500
 (length 0.5m, outer jacket: PUR)
 4-pole M12 fem. conn. (D-coded)
 for connection of an external
 CAT5 cable, e.g.
 cab-eth/M12D-RJ45-flx-(length)

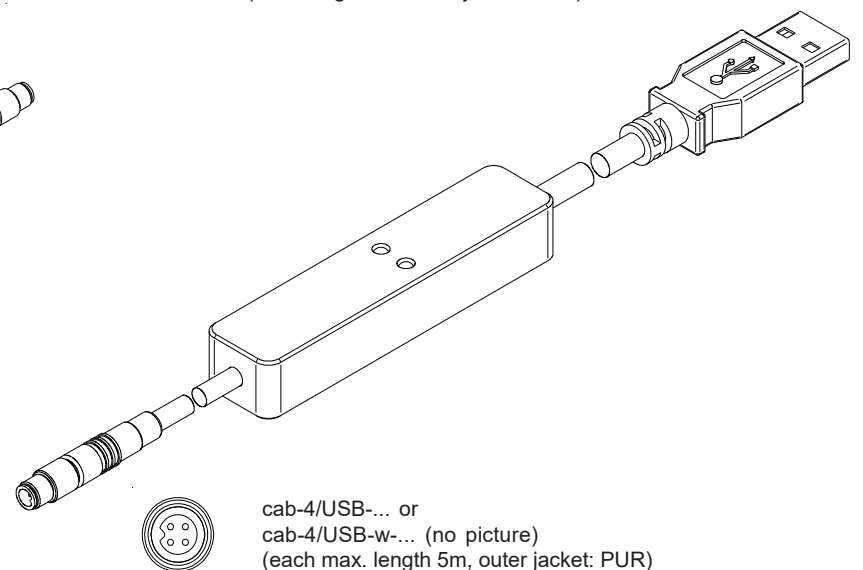

cab-4/USB-... or
 cab-4/USB-w-... (no picture)
 (each max. length 5m, outer jacket: PUR)

**LED Display****LED display:**

The two LEDs visualize the physical state of the outputs OUT0 und OUT1.

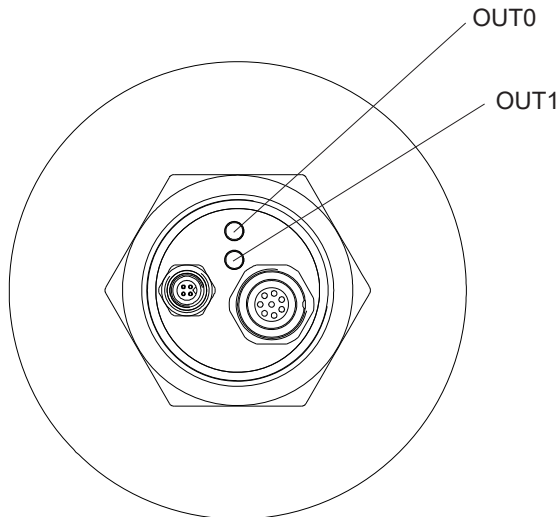
**Measuring Principle****Measuring principle of the sensor SPECTRO-M-2-15-3.5/4.25:**

The **SPECTRO-M-2-15-3.5/4.25** sensor is an optoelectronic measuring instrument for checking the coating thickness of organic layers on metallic reflective surfaces in the mid-infrared range (MIR).

The measuring principle is based on the wavelength-selective absorption property of certain organic materials in the MIR range. By means of broadband infrared radiation and narrowband receivers, the reflected radiation intensities in the two wavelength ranges are recorded. From the recorded channels, the application thickness of the material on the metal base can be determined using Lambert-Beer's law, which establishes the relationship between absorption behaviour and layer thickness.

Subsequent scaling of the relative coating thickness value enables adaptation to different coating materials as well as metal types and surfaces.



Parameterization

Parameterization via Windows® software SPECTRO-M-2-Scope:

The PC software SPECTRO-M-2-Scope is a tool for processing and analysing the measurement data and can be used to display the signals and values measured by the sensor on the screen. A recorder function allows recording on the PC.

Different views of the measurement data allow certain aspects of the measurement to be highlighted.

Furthermore, the sensor can be parameterised using the SPECTRO-M-2-Scope software, for example, the transmission power of the MIR emitters can be set, but also the amplification factor of the two receiver lines.

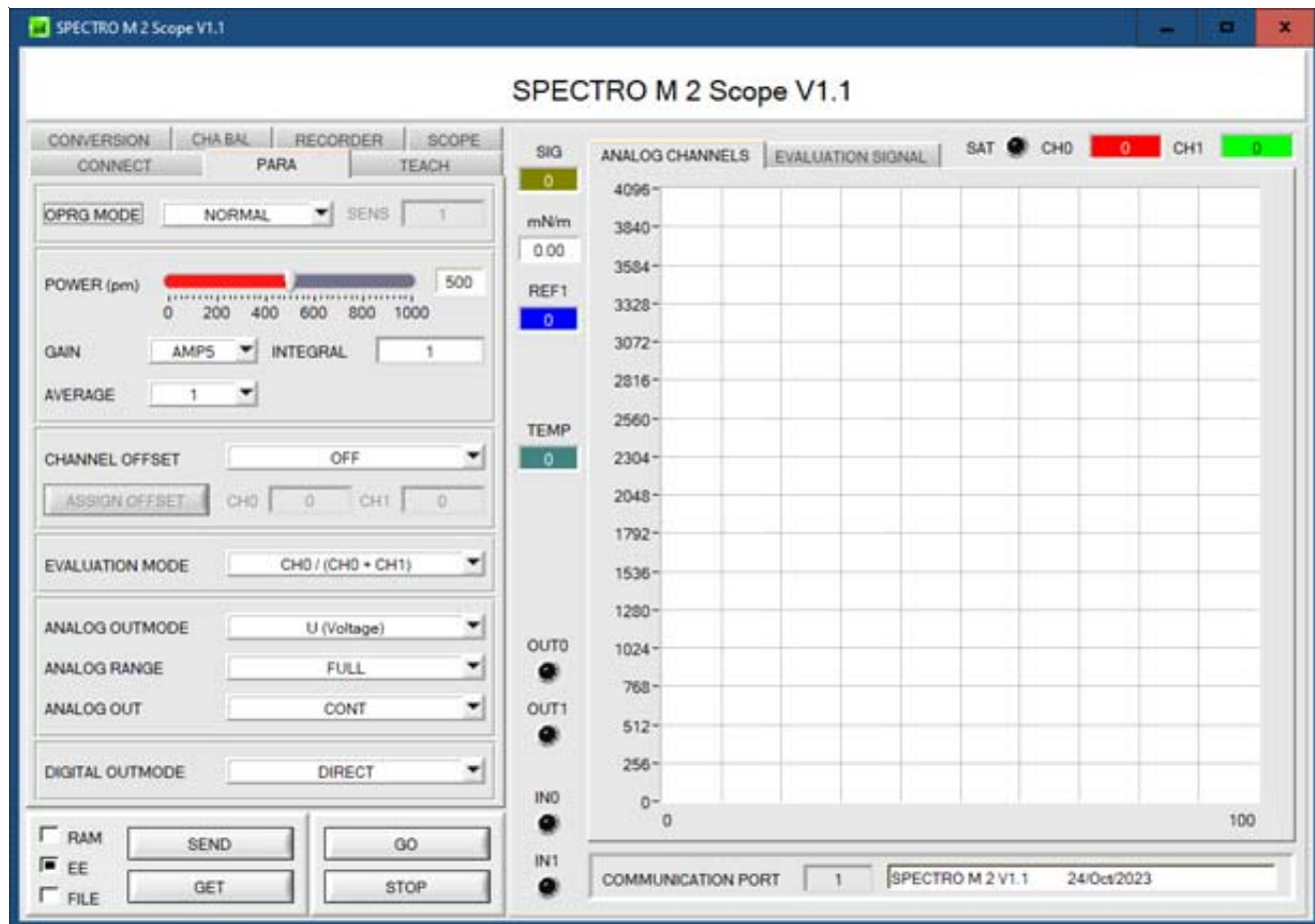



Firmware-Update

Firmware update via the Windows® software „Firmware Loader“:

(The current software version is available for download on our website.)

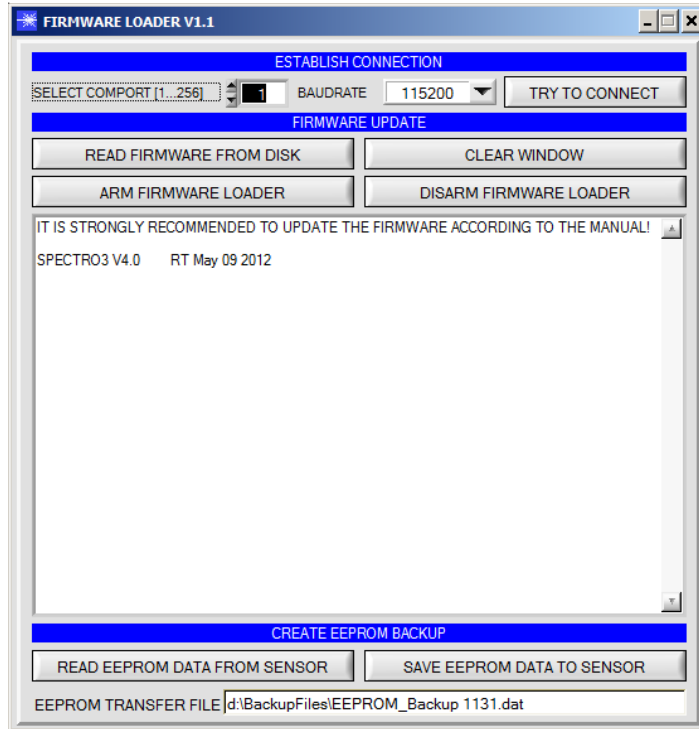

The software „Firmware Loader“ allows the user to perform an automatic firmware update. The update will be carried out through the RS232 interface.

An initialisation file (xxx.ini) and a firmware file (xxx.elf.S) are required for performing a firmware update. These files can be obtained from your supplier. In some cases an additional firmware file for the program memory (xxx.elf.p.S) is also needed, and this file will be automatically provided together with the other two files.



Spacer

SPECTRO-M-15-OFL
(please order separately)



SPECTRO-M-2-15-OFL

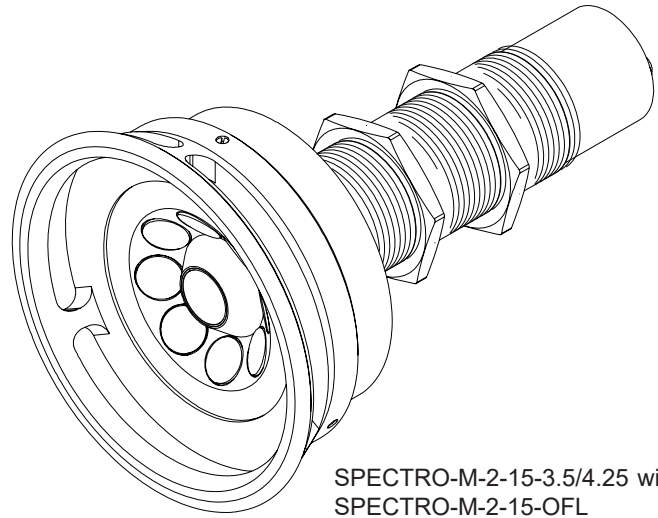

SPECTRO-M-2-15-3.5/4.25 with
SPECTRO-M-2-15-OFL

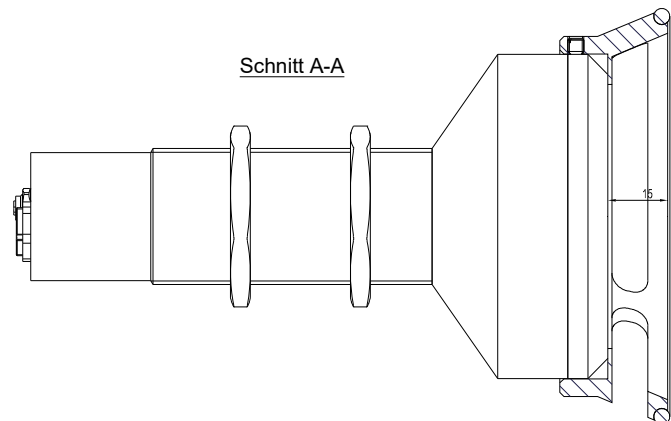
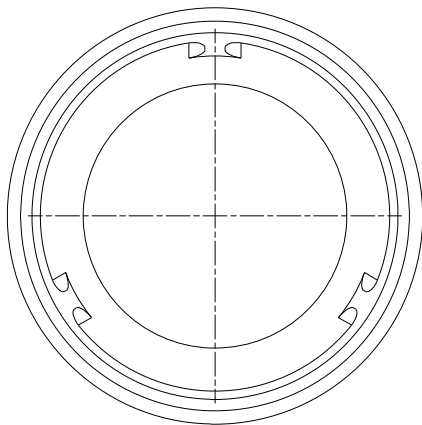
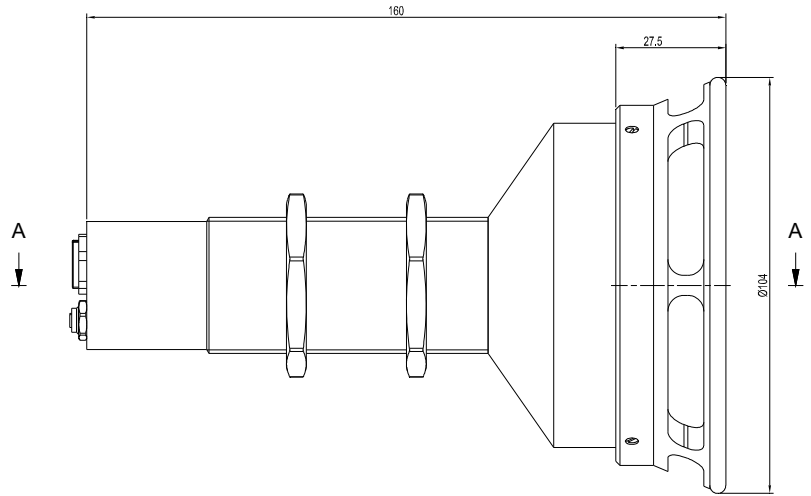
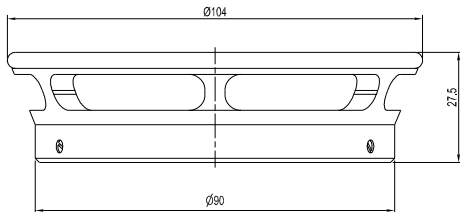
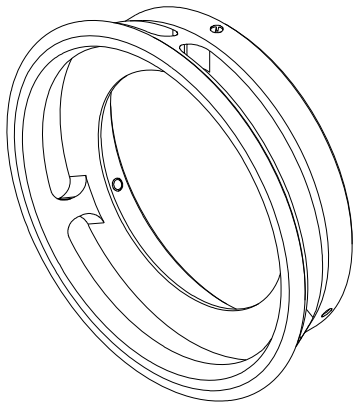



Diagrams

SPECTRO-M-2 signal depending on the distance to the object

Type of object: ALUMINUM GARDOBOND OAA 6014/4

POWER: 885 AMP3 DC INTEGRAL 3

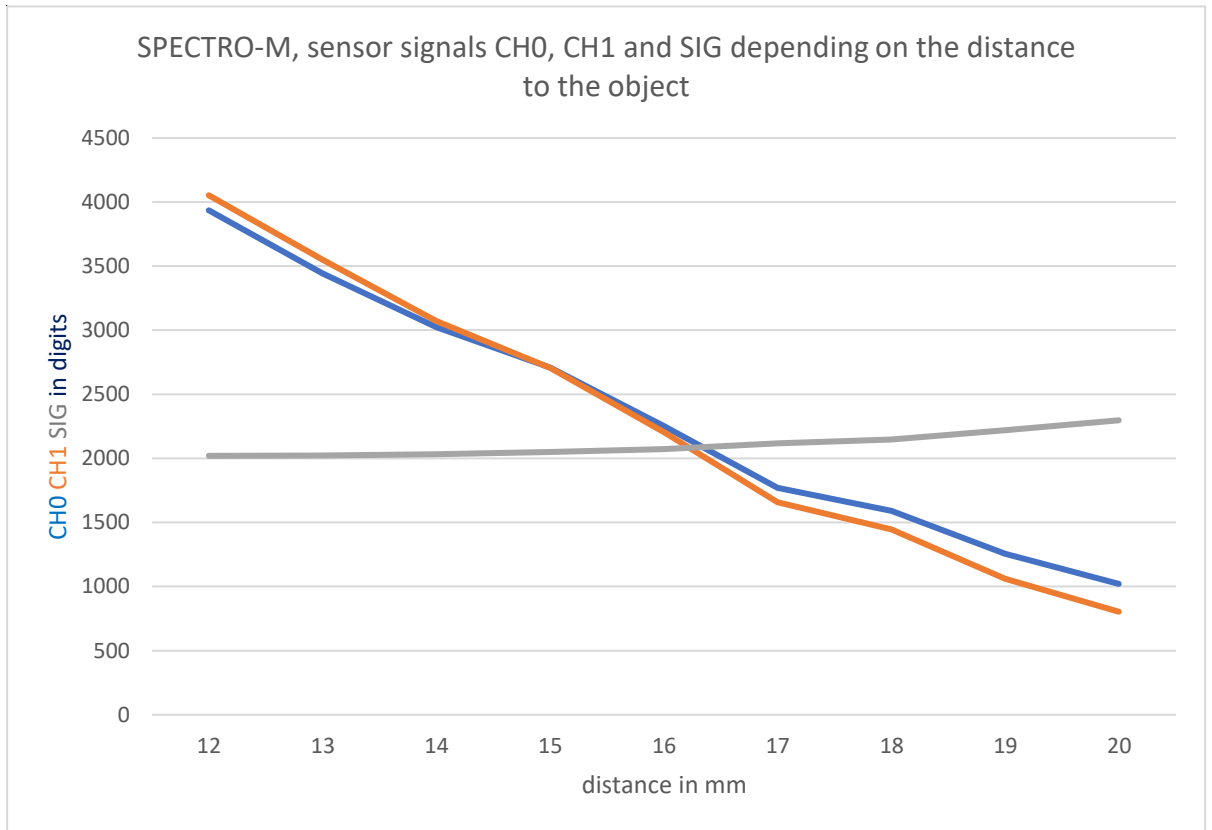

Spot size SPECTRO-M-2

5mm ALUMINUM stripe

Distance to the object: 15mm

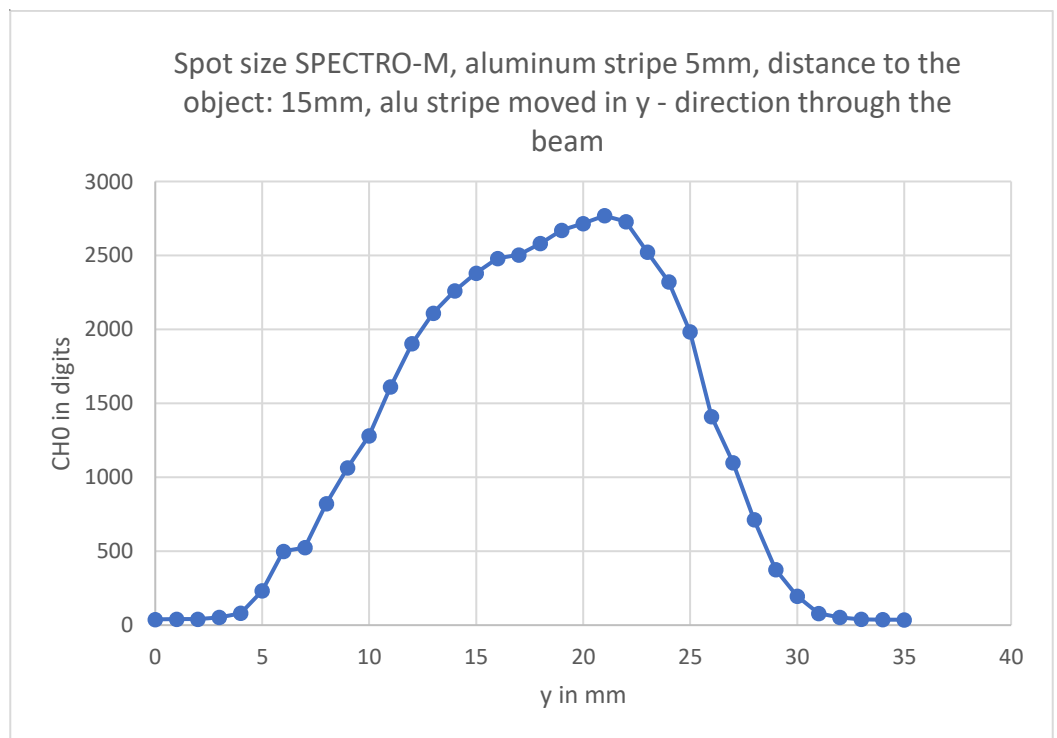



Diagrams

SPECTRO-M-2

CARBON BLACK surface Ø 25mm on ALUMINUM GARDOBOND OAA 6014/4 background

Distance to the object: 15mm

