

SPECTRO Series

► SPECTRO-3-UV-SLA

- Measuring range typ. 1 mm ... 50 mm
- Integrated transmitter and receiver optics
- RS232 interface (USB or Ethernet adapter is available)
- UV-LED, 375 nm ((AC-/DC-operation or OFF for luminous objects can be switched)
- Transmitter power of UV LED can be adjusted for excitation of luminescent marks
- Detection of different fluorescent colors
- Insensitive to outside light (in AC-operation)
- Brightness correction can be activated (STATIC/DYNAMIC)
- Scan frequency max. 90 kHz (in DC- or OFF-operation)
- 3 analog outputs, that either provide the red, green, blue components or the calculated color coordinates (X, Y, INT or s, i, M) from 0...+10V or 4...20mA
- Parameterizable via Windows® software, scope function
- Temperature compensated
- Averaging can be activated (from 1 up to over 32000 values)
- 3-color filter detector (true color detector: "human color perception")

In Proud Partnership with Sensor Instruments

PAQUIN
SENSORS

For technical support, sales, & distribution
within the USA & Canada

www.paquin.com | (800) 831-8217 | paquinsensors@paquin.com



Design

Product name:

SPECTRO-3-UV-SLA

(incl. Windows® PC software
SPECTRO3-SLA-Scope)

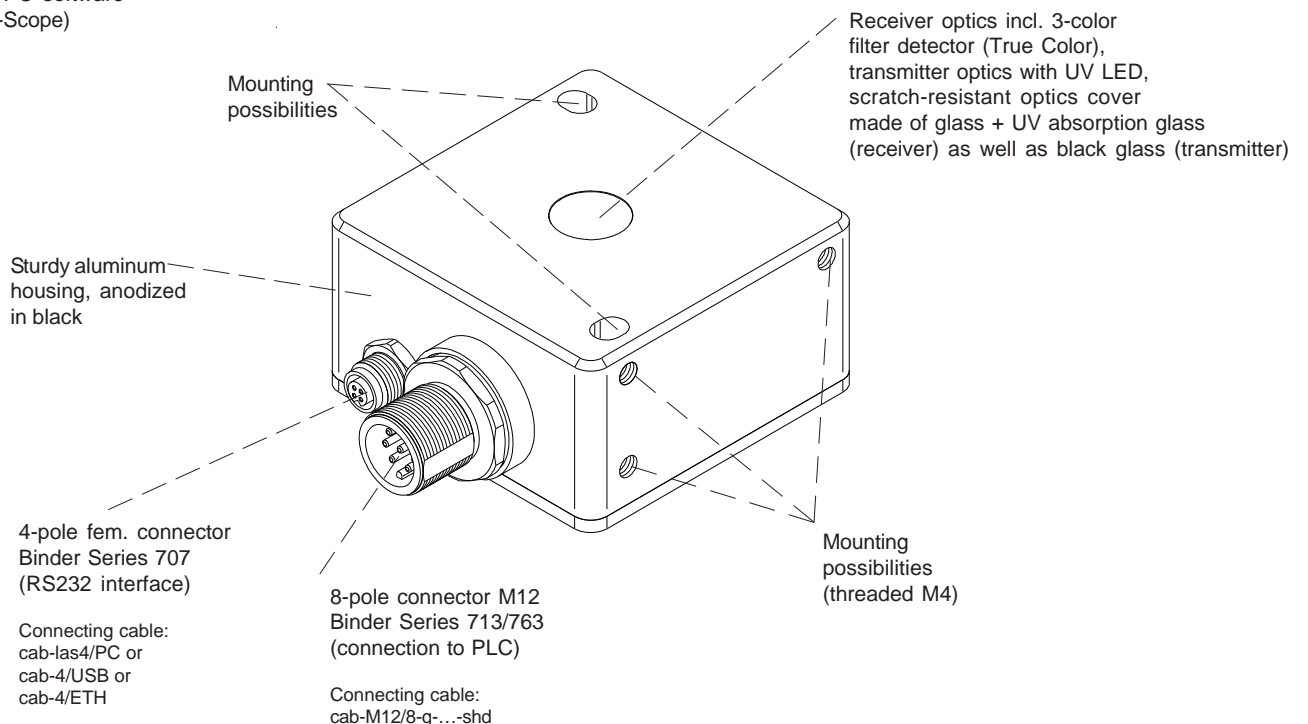



Technical Data

| Model | SPECTRO-3-UV-SLA | | | | | | |
|--|--|---------------------------------|-----------------------------------|----------------------------------|-----------------------------------|----------------------------------|-----------------------------------|
| Voltage supply | +24VDC ($\pm 10\%$), reverse polarity protected, overcurrent protected | | | | | | |
| Current consumption | < 160 mA | | | | | | |
| Max. switching current | 100 mA, short circuit proof | | | | | | |
| Input digital (1x) | IN0 (Pin 3), digital (0V/+24V) | | | | | | |
| Outputs analog (3x) | ANA OUT R (red), ANA OUT gG (green), ANA OUT B (blue) (Pin 6, 7 and 8): Voltage output 0...+10V or current output 4...20mA (R,G,B or X,Y,INT or s,i,M) | | | | | | |
| Interface | RS232 | | | | | | |
| Averaging | max. 32768 values, adjustable via PC software | | | | | | |
| Scan frequency | LED operation, can be switched via PC software: AC operation: max. 25 kHz (depends on parameterization) DC and OFF operation: max. 90 kHz (depends on parameterization) | | | | | | |
| Analog band width | max. 90 kHz (-3dB) | | | | | | |
| Transmitter (light source) | UV-LED, 375 nm | | | | | | |
| Transmitter control | can be switched via PC software: AC operation (LED MODE-AC), DC operation (LED MODE-DC), OFF operation (LED MODE-OFF) | | | | | | |
| Measuring range | typ. 1 mm ... 50 mm | | | | | | |
| Receiver | 3-color filter detector (TRUE COLOR detector, "human color perception"), color filter curves acc. to CIE 1931 | | | | | | |
| Receiver gain setting | 8 steps (AMP1 ... AMP8), adjustable via PC software | | | | | | |
| Ambient light | max. 5000 Lux | | | | | | |
| Detection range (half intensity width) | <table style="width: 100%; border: none;"> <tr> <td style="width: 50%;">typ. 5 mm at a distance of 5 mm</td> <td style="width: 50%;">typ. 10 mm at a distance of 30 mm</td> </tr> <tr> <td>typ. 6 mm at a distance of 10 mm</td> <td>typ. 12 mm at a distance of 40 mm</td> </tr> <tr> <td>typ. 8 mm at a distance of 20 mm</td> <td>typ. 14 mm at a distance of 50 mm</td> </tr> </table> | typ. 5 mm at a distance of 5 mm | typ. 10 mm at a distance of 30 mm | typ. 6 mm at a distance of 10 mm | typ. 12 mm at a distance of 40 mm | typ. 8 mm at a distance of 20 mm | typ. 14 mm at a distance of 50 mm |
| typ. 5 mm at a distance of 5 mm | typ. 10 mm at a distance of 30 mm | | | | | | |
| typ. 6 mm at a distance of 10 mm | typ. 12 mm at a distance of 40 mm | | | | | | |
| typ. 8 mm at a distance of 20 mm | typ. 14 mm at a distance of 50 mm | | | | | | |
| Reproducibility | in the X, Y color range each 1 digit at 12-bit A/D conversion | | | | | | |
| Temperature drift X,Y | $\Delta X/\Delta T$; $\Delta Y/\Delta T$ typ. 0,2 digits/ $^{\circ}\text{C}$ (< 0,01% / $^{\circ}\text{C}$) | | | | | | |
| Color difference | $\Delta E \geq 0,5$ | | | | | | |
| Color space | X Y INT siM (Lab) | | | | | | |
| Housing dimensions | LxWxH approx. 50 mm x 50 mm x 27 mm (without flange connectors) | | | | | | |
| Housing material | aluminum, anodized in black | | | | | | |
| Enclosure rating | IP64 | | | | | | |
| Connecting cables | to PLC: cab-M12/8-g-...-shd to PC/RS232 interface: cab-las4/PC or cab-las4/PC-w to PC/USB interface: cab-4/USB or cab-4/USB-w to PC/Ethernet interface: cab-4/ETH | | | | | | |
| Type of connector | connection to PLC: 8-pole M12-connector (Binder 713/763), connection to PC: 4-pole fem. connector (Binder 707) | | | | | | |
| Operating temp. range | -20 $^{\circ}\text{C}$... +55 $^{\circ}\text{C}$ | | | | | | |
| Storage temperature range | -20 $^{\circ}\text{C}$... +85 $^{\circ}\text{C}$ | | | | | | |
| EMC test acc. to | DIN EN 60947-5-2 | | | | | | |



Dimensions

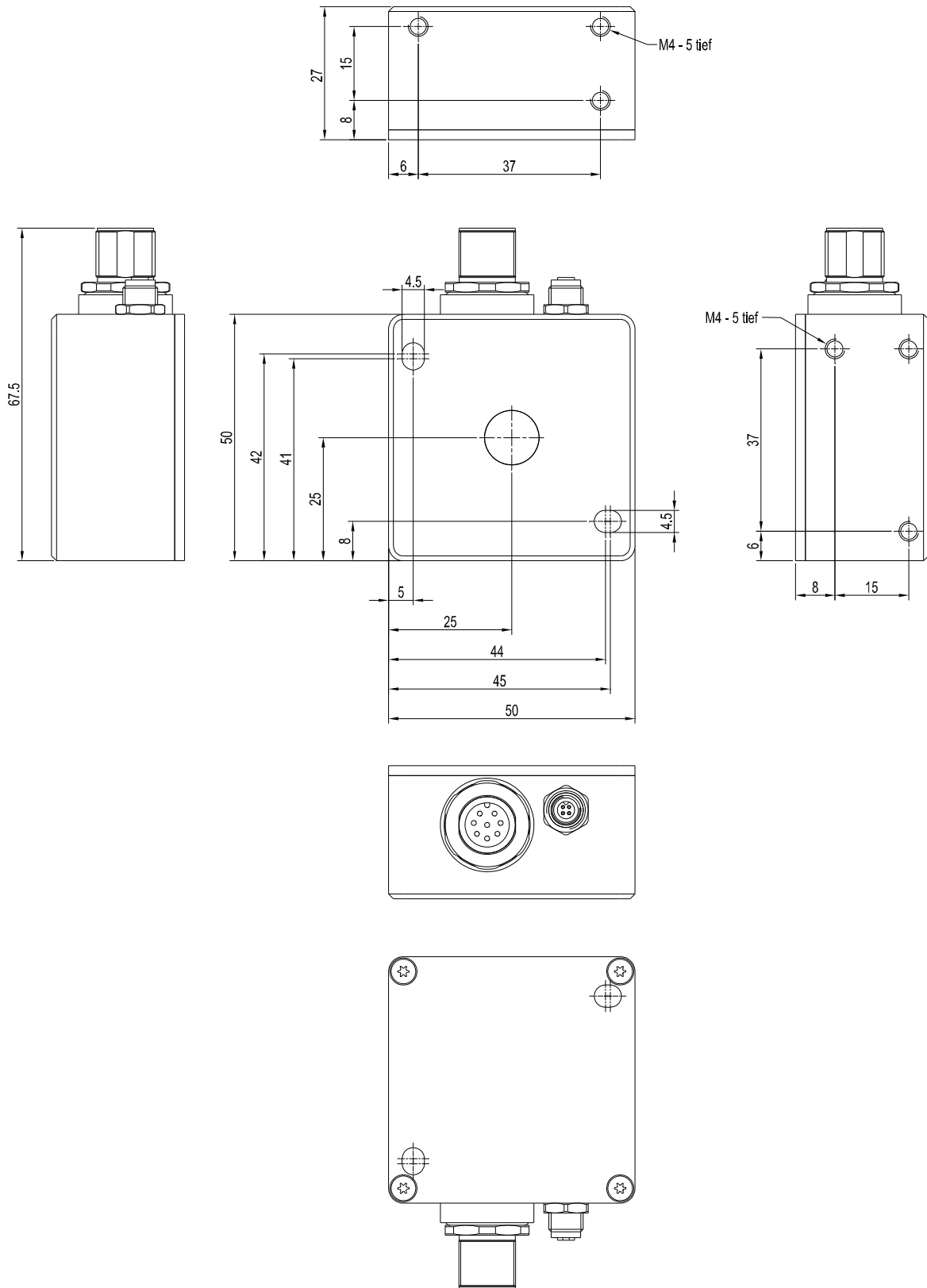

All dimensions in mm



Connector Assignment
Connection to PLC:**8-pole M12 connector Binder Series 713/763**

| Pin: | Color: | Assignment: |
|------|--------|--|
| 1 | white | GND (0V) |
| 2 | brown | +24VDC ($\pm 10\%$) |
| 3 | green | IN0 |
| 4 | yellow | not connected |
| 5 | grey | not connected |
| 6 | pink | ANA OUT (analog R or X or s: 0...+10V or 4...20mA) |
| 7 | blue | ANA OUT (analog G or Y or i: 0...+10V or 4...20mA) |
| 8 | red | ANA OUT (analog B or INT or M: 0...+10V or 4...20mA) |

Connecting cable:
 cab-M12/8-g-(length)-shd (shielded)
 (standard length 2m)

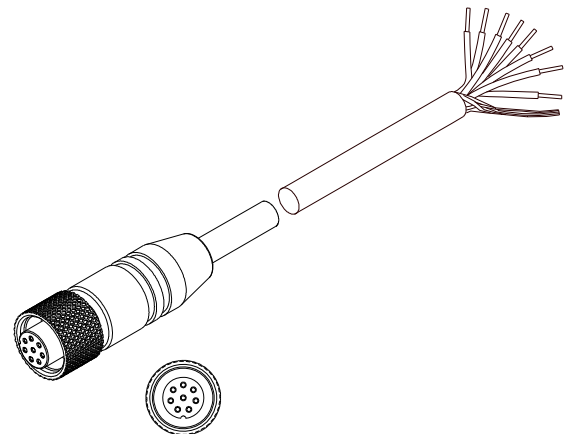

cab-M12/8-g-...-shd
 (max. length 5m, outer jacket: PUR)

Connection to PC:**4-pole fem. connector Binder Series 707**

| Pin: | Assignment: |
|------|-------------------|
| 1 | +24VDC (+Ub, OUT) |
| 2 | GND (0V) |
| 3 | RxD |
| 4 | TxD |

Connection via RS232 interface at the PC:

Connecting cable:
 cab-las4/PC-(length)
 cab-las4/PC-w-(length) (angle type 90°)
 (standard length 2m)

alternative:**Connection via USB interface at the PC:**

Connecting cable (incl. driver software):
 cab-4/USB-(length)
 cab-4/USB-w-(length) (angle type 90°)
 (standard length 2m)

alternative:**Connection to local network via Ethernet bus:**

Adapter (incl. software „SensorFinder“):
 cab-4/ETH-500
 (standard length 0.5m)

Optional: External CAT5 cable, e.g.
 cab-eth/M12D-RJ45-flx-(length)

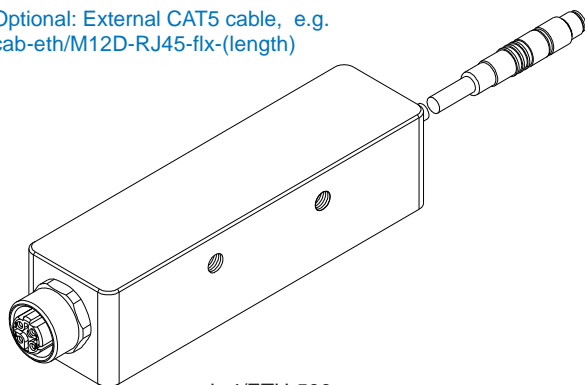

cab-4/ETH-500
 (length 0.5m, outer jacket: PUR)
 4-pole M12 fem. conn. (D-coded)
 for connection of an external
 CAT5 cable, e.g.
 cab-eth/M12D-RJ45-flx-(length)

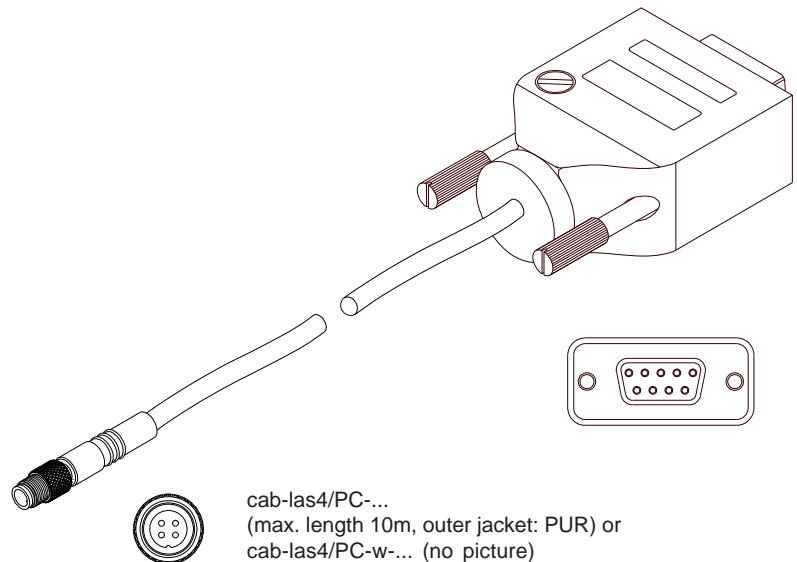

cab-las4/PC-...
 (max. length 10m, outer jacket: PUR) or
 cab-las4/PC-w-... (no picture)
 (max. length 5m, outer jacket: PUR)

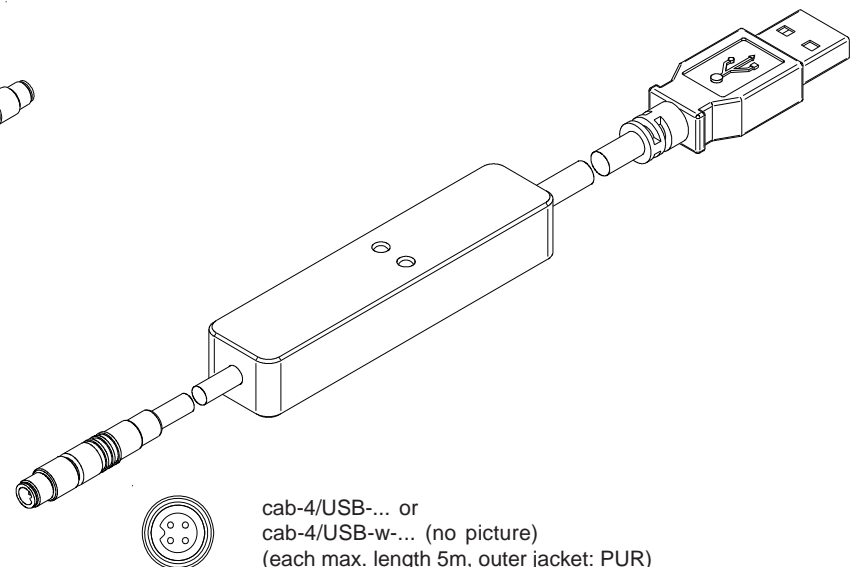

cab-4/USB-... or
 cab-4/USB-w-... (no picture)
 (each max. length 5m, outer jacket: PUR)

**Measuring Principle****Measuring principle of the color sensors of SPECTRO-3-SLA series:**

The SPECTRO-3-...-SLA provides highly flexible signal acquisition. For example, the sensor can be operated in alternating-light mode (AC mode), which makes the sensor insensitive to extraneous light. It also can be set to constant-light mode (DC mode), which makes the sensor extremely fast. An OFF function turns off the integrated light source at the sensor and changes to DC operation. The sensor then can detect so-called „self-luminous objects“. With the stepless adjustment of the integrated light source as well as the selectable gain of the receiver signal and an INTEGRAL function the sensor can be set to almost any surface or any „self-luminous object“.

When the integrated light source of the SPECTRO-3-...-SLA color sensor is activated, the sensor detects the radiation that is diffusely reflected from the object. As a light source the SPECTRO-3 color sensor uses a white-light LED with adjustable transmitter power. An integrated 3-fold receiver for the red, green, and blue content of the light that is reflected from the object, or the light that is emitted by a „self-luminous object“, is used as a receiver.

The sensor is equipped with 3 analog outputs that either provide the red, green, blue components or the calculated color coordinates (X, Y, INT or s, i, M) from 0...+10V or 4...20mA.

Parameters and measurement values can be exchanged between a PC and the SPECTRO-3-...-SLA color sensor through the serial RS232 interface. All the parameters for color detection also can be saved to the non-volatile EEPROM of the SPECTRO-3-...-SLA color sensor through this serial RS232 interface. When parameterisation is finished, the color sensor continues to operate with the current parameters in STAND-ALONE mode without a PC.

The sensors of the SPECTRO-3-...-SLA series can be calibrated (white-light balancing). Balancing can be performed to any white surface. A ColorChecker™ table with 24 color fields is available as an alternative. White-light balancing or calibration can be performed to one of the white fields.

As a light source the SPECTRO-3-UV-SLA (or SPECTRO-3-FIO-UV-SLA) color sensor uses a UV-LED (375 nm) with adjustable transmitter power to excite the luminescent marking. These UV-sensors can be optimally adjusted to almost any luminescent colorant that can be excited in the long-wave UV range (365 nm or 375 nm). The sensors of the SPECTRO-3-...-UV-SLA series also can be calibrated. Analogous to white-light balancing with color sensors, balancing of the SPECTRO-3-UV-SLA (or SPECTRO-3-FIO-UV-SLA) could be performed to any luminescent color marking.



Parameterization

Windows® user interface:

The color sensor is parameterized under Windows® with the SPECTRO3-SLA-Scope software. The Windows® user interface facilitates the teach-in process at the color sensor and supports the operator in the task of adjustment and commissioning of the color sensor.

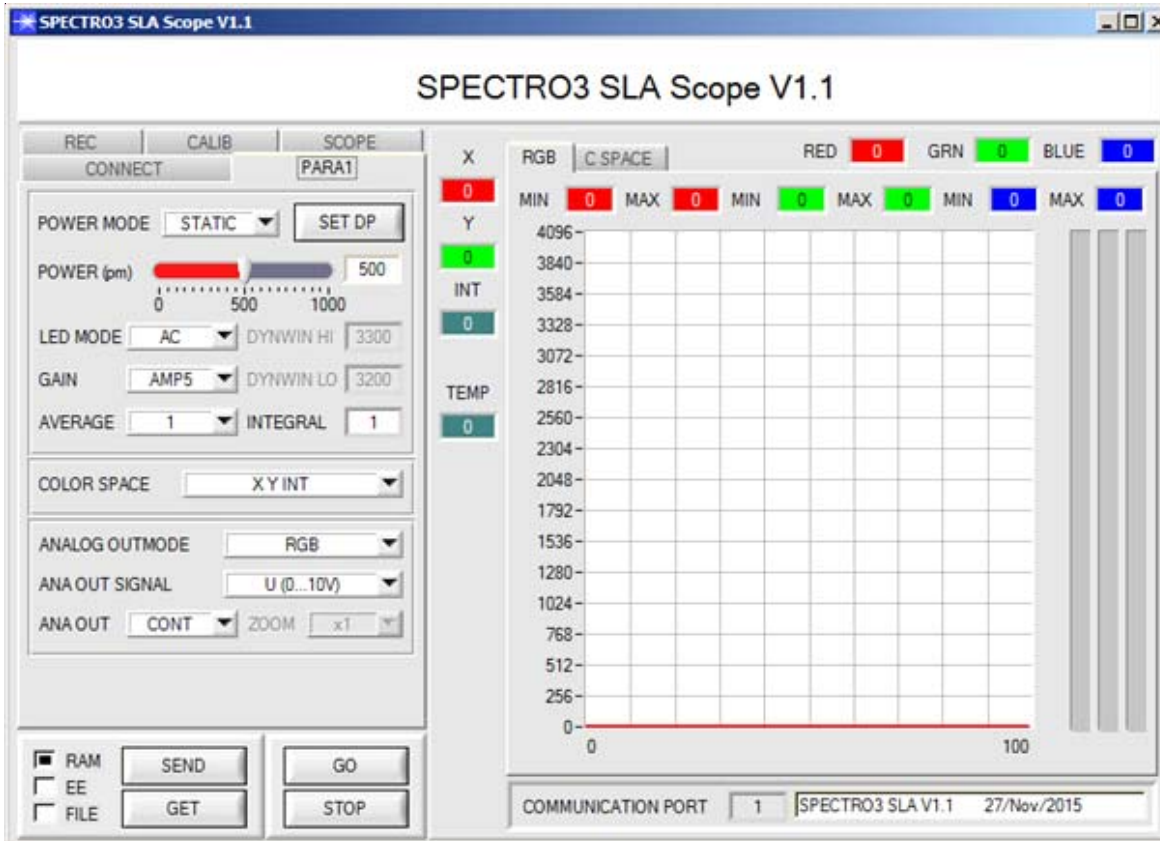

Under Windows® representation of the color value on a PC in numeric form and in a color chart, and representation of RGB values in a time chart. In addition the current RGB values are displayed as a bar chart.

The RS232 interface (tab PARA1) is used for setting parameters such as:

- POWER MODE: Light power of the LED
- SET DP Set Double Parameter (for setting of two parameter sets)
- LED MODE: Triggering of the internal light source
- GAIN: Used for setting the gain of the receiver
- AVERAGE: Used for adjusting the number of scanning values (measurement values) over which the raw signal measured at the receiver is averaged. A higher AVERAGE default value reduces noise of the raw signals at the receiver unit and there will be a decrease of the maximal available switching frequency of the sensor
- INTEGRAL: Used to set the number of scan values (measurement values) over which the raw signal measured at the receiver is summed up. This integral function allows the reliable detection even of extremely weak signals
- ANALOG OUTMODE: used to determine the signals that the sensor provides at its analog output (ANA OUT) (R G B, RGB MM, X Y INT, s i M or CS REF)
- INTLIM: Minimum intensity required for color evaluation
- COLOR SPACE: Used to set the color space that should be calculated (X Y INT or s i M)

Tab CALIB Selection of calibration (white light balancing or offset calibration)
 Tab SCOPE Visualises an oscilloscope
 Tab REC Data recorder



Firmware Update

Firmware update by means of the software „FirmwareLoader“:

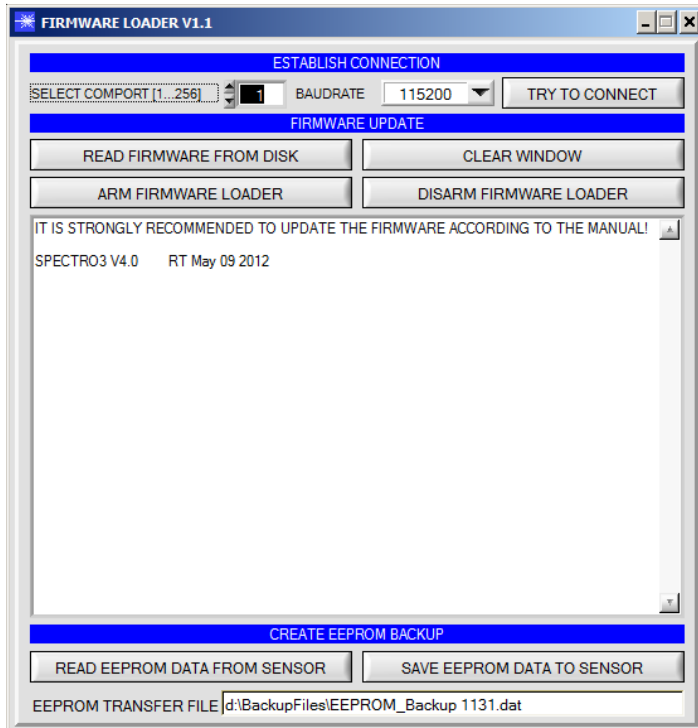

The software „Firmware Loader“ allows the user to perform an automatic firmware update. The update will be carried out through the RS232 interface.

An initialisation file (xxx.ini) and a firmware file (xxx.elf.S) are required for performing a firmware update. These files can be obtained from your supplier. In some cases an additional firmware file for the program memory (xxx.elf.p.S) is also needed, and this file will be automatically provided together with the other two files.



Diagrams

Diagramme: DETECTION RANGE (HALF INTENSITY WIDTH) and RELATIVE INTENSITY SPECTRO-3-UV-SLA

Detection range (half intensity width)
 SPECTRO-3-UV-SLA:
 8 mm (typ.) at a working distance of 20 mm

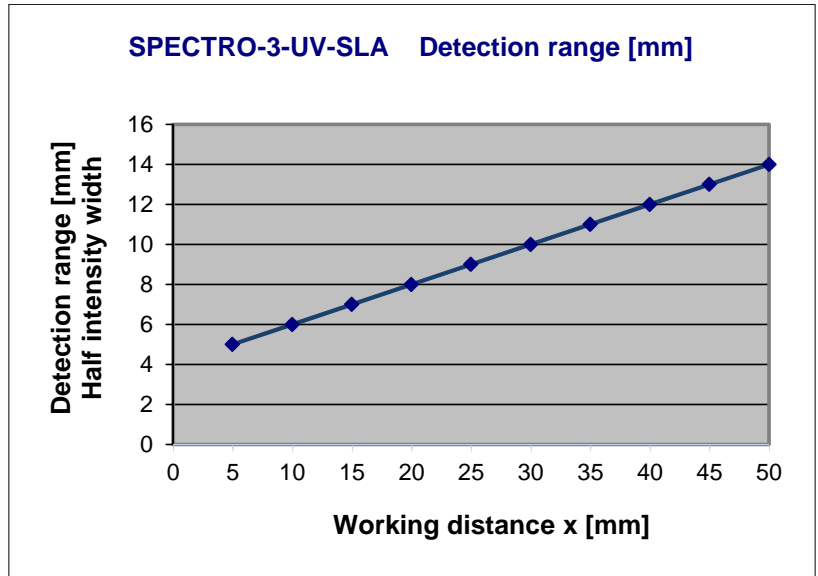

Relative Intensity:
 SPECTRO-3-UV-SLA:
 100% at a working distance of 7 mm
 (INTENSITY 2675)

