

SPECTRO Series

► SPECTRO-3-POF-SLE

- Big assortment of plastic optic fibers of POF Series available (diffuse reflection or through-beam sensor types)
- Working range for diffuse reflection types: typ. 1 mm ... 100 mm
Working range for through-beam types: typ. 1 mm ... 500 mm (depends on the optic fiber type used)
- Up to 31 colors can be taught (max. 64 colors in GROUP mode)
- RS232 interface (USB or Ethernet adapter is available)
- Super-bright white-light LED (AC/DC-operation or OFF for luminous objects can be switched)
- Color detection, contrast detection, and gray scale detection
- Insensitive to outside light (in AC-operation)
- Brightness correction can be activated (STATIC/DYNAMIC)
- Scan frequency max. 35 kHz (in DC- or OFF-operation)
- Switching frequency typ. 35 kHz
- 5 digital outputs to output the detected colors (provided either as a binary code or directly, if only up to 5 colors are to be detected)
- Several TEACH functions (via PC or PLC)
- Various evaluation algorithms can be activated
- "BEST HIT" mode ("human color assessment")
- Parameterizable via Windows® software, scope function
- Temperature compensated
- Averaging can be activated (from 1 up to over 32000 values)
- Color control of luminous objects (LEDs, halogen lamps, displays, ...)
- 3-color filter detector (true color detector: "human color perception")

In Proud Partnership with Sensor Instruments

PAQUIN
SENSORS

For technical support, sales, & distribution
within the USA & Canada

www.paquin.com | (800) 831-8217 | paquinsensors@paquin.com

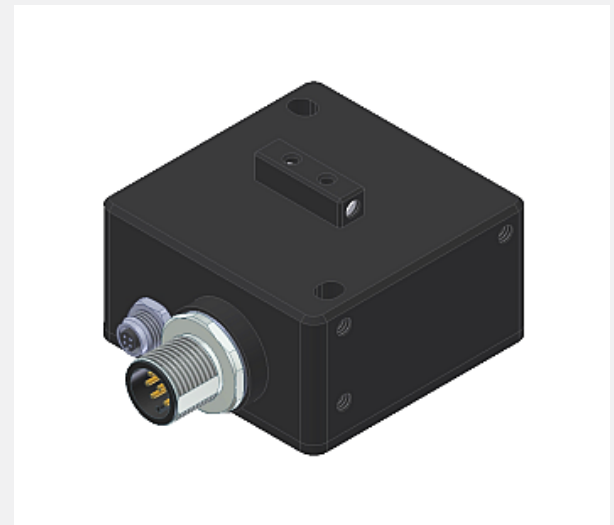

Design

Product name:

SPECTRO-3-POF-SLE

(incl. Windows® PC software
SPECTRO3-SLE-Scope and
SPECTRO3-COMFORT-Scope)

Accessories: (p. 8-9)

Fiber optics: POF Series

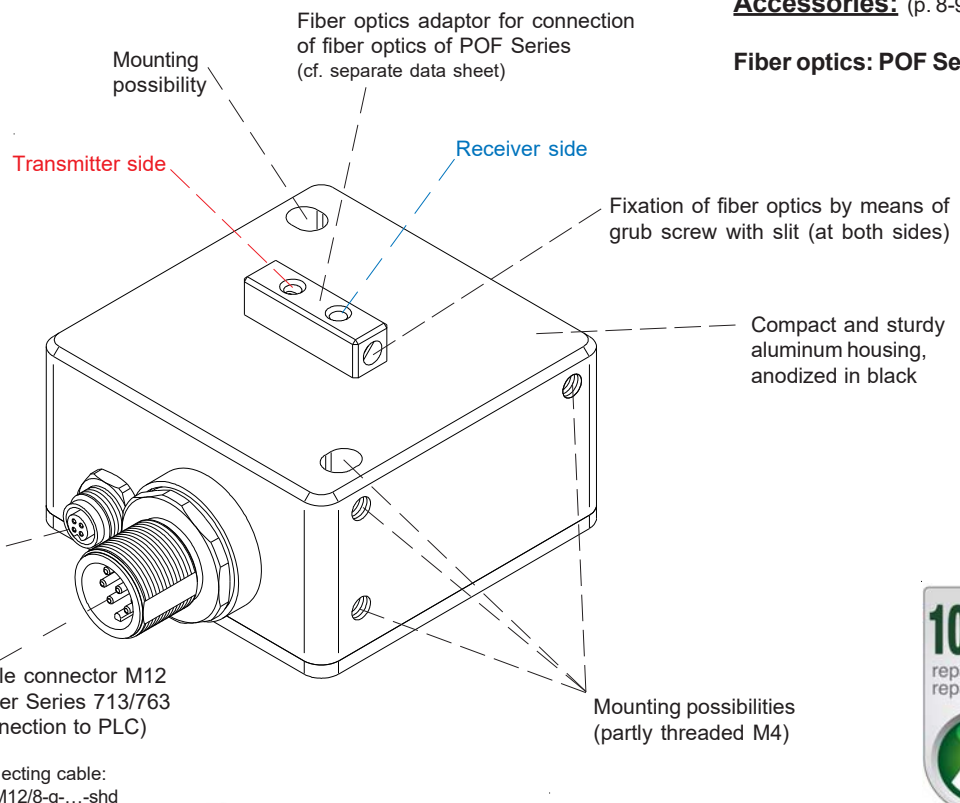



Technical Data

Model	SPECTRO-3-POF-SLE
Voltage supply	+24VDC ($\pm 10\%$), reverse polarity protected, overcurrent protected
Current consumption	< 160 mA
Max. switching current	100 mA, short circuit proof
Input digital (1x)	IN0 (Pin 3), digital (0V/+24V)
Outputs digital (5x)	OUT0 ... OUT1 (Pin 4 ... Pin 8): digital (0V/+24V), npn-/pnp-able (bright-/dark-switching, can be switched)
Interface	RS232
Pulse lengthening	0 ... 100 ms, adjustable via PC software
Averaging	max. 32768 values, adjustable via PC software
Scan frequency	LED operation, can be switched via PC software: AC operation: max. 20 kHz (depends on parameterization) DC and OFF operation: max. 35 kHz (depends on parameterization)
Switching frequency	typ. 35 kHz
Transmitter (light source)	super-bright white-light LED
Transmitter control	can be switched via PC software: AC operation (LED MODE-AC), DC operation (LED MODE-DC), OFF operation (LED MODE-OFF)
Object distance (measuring range)	with reflected light fiber optics: typ. 1 mm ... 100 mm (depends on selected fiber optics of POF Series) with transmitted light fiber optics: typ. 1 mm ... 500 mm (depends on selected fiber optics of POF Series)
Receiver	3-color filter detector (TRUE COLOR detector, "human color perception"), color filter curves acc. to CIE 1931
Receiver gain setting	8 steps (AMP1 ... AMP8), adjustable via PC software
Ambient light	max. 5000 Lux
Size of light spot	typ. \varnothing 1 mm ... \varnothing 20 mm (depends on selected fiber optics of POF series)
Reproducibility	in the X, Y color range each 1 digit at 12-bit A/D conversion
Temperature drift X,Y	$\Delta X/\Delta T$; $\Delta Y/\Delta T$ typ. 0,2 digits/ $^{\circ}\text{C}$ (< 0,01% / $^{\circ}\text{C}$)
Color difference	$\Delta E \geq 0,5$
Color space	X Y INT siM (Lab)
Color memory capacity	non-volatile EEPROM with parameter sets for max. 31 colors (max. 64 colors in GROUP mode)
Housing dimensions	LxWxH approx. 50 mm x 50 mm x 32.5 mm (incl. adaptor for plastic optic fibers, without flange connectors)
Housing material	aluminum, anodized in black
Enclosure rating	IP64
Connecting cables	to PLC: cab-M12/8-g-...-shd to PC/RS232 interface: cab-las4/PC or cab-las4/PC-w to PC/USB interface: cab-4/USB or cab-4/USB-w to PC/Ethernet interface: cab-4/ETH
Type of connector	connection to PLC: 8-pole M12-connector (Binder 713/763), connection to PC: 4-pole fem. connector (Binder 707)
Operating temp. range	-20 $^{\circ}\text{C}$... +55 $^{\circ}\text{C}$
Storage temperature range	-20 $^{\circ}\text{C}$... +85 $^{\circ}\text{C}$
EMC test acc. to	DIN EN 60947-5-2

Dimensions

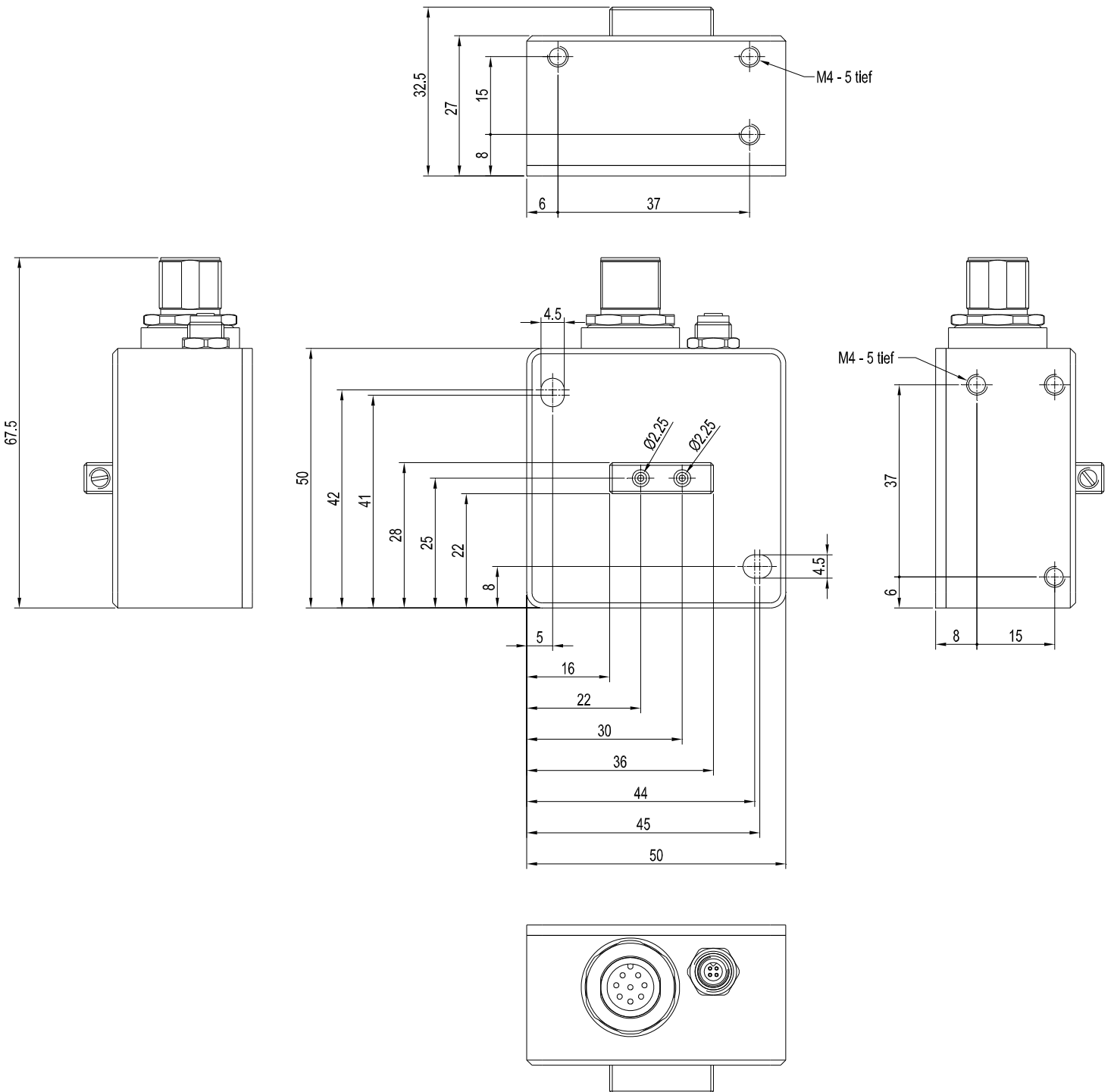

All dimensions in mm



Connector Assignment
Connection to PLC:**8-pole M12 connector Binder Series 713/763**

Pin:	Color:	Assignment:
1	white	GND (0V)
2	brown	+24VDC ($\pm 10\%$)
3	green	IN0
4	yellow	OUT0 (Digital 0: typ. 0 ... 1V, Digital 1: typ. +Ub - 10%)
5	grey	OUT1 (Digital 0: typ. 0 ... 1V, Digital 1: typ. +Ub - 10%)
6	pink	OUT2 (Digital 0: typ. 0 ... 1V, Digital 1: typ. +Ub - 10%)
7	blue	OUT3 (Digital 0: typ. 0 ... 1V, Digital 1: typ. +Ub - 10%)
8	red	OUT4 (Digital 0: typ. 0 ... 1V, Digital 1: typ. +Ub - 10%)

Connecting cable:
 cab-M12/8-g-(length)-shd (shielded)
 (standard length 2m)

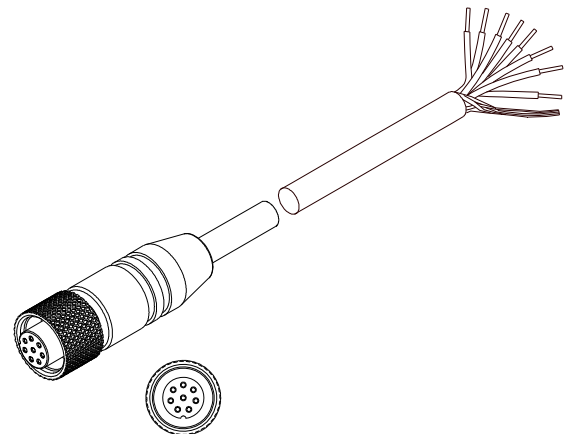

cab-M12/8-g-...-shd
 (max. length 5m, outer jacket: PUR)

Connection to PC:**4-pole fem. connector Binder Series 707**

Pin:	Assignment:
1	+24VDC (+Ub, OUT)
2	GND (0V)
3	RxD
4	TxD

Connection via RS232 interface at the PC:

Connecting cable:
 cab-las4/PC-(length)
 cab-las4/PC-w-(length) (angle type 90°)
 (standard length 2m)

alternative:**Connection via USB interface at the PC:**

Connecting cable (incl. driver software):
 cab-4/USB-(length)
 cab-4/USB-w-(length) (angle type 90°)
 (standard length 2m)

alternative:**Connection to local network via Ethernet bus:**

Adapter (incl. software „SensorFinder“):
 cab-4/ETH-500
 (standard length 0.5m)

Optional: External CAT5 cable, e.g.
 cab-eth/M12D-RJ45-flx-(length)

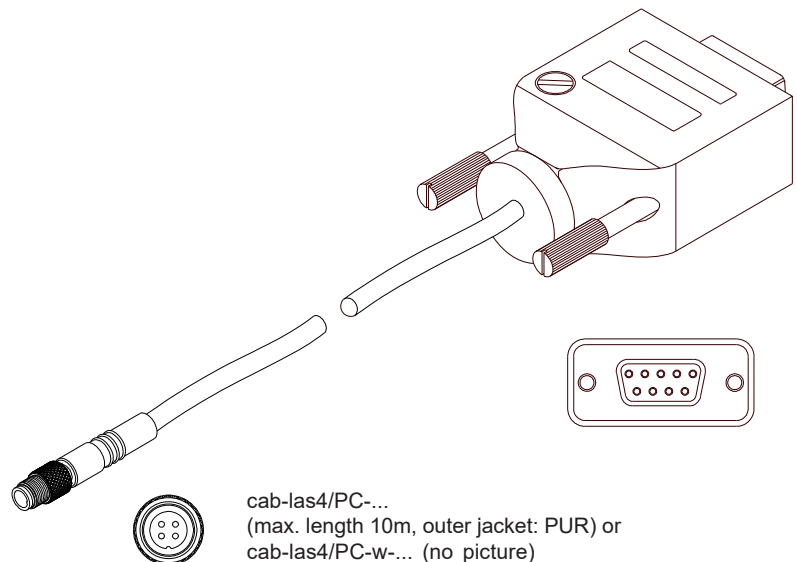

cab-las4/PC-...
 (max. length 10m, outer jacket: PUR) or
 cab-las4/PC-w-... (no picture)
 (max. length 5m, outer jacket: PUR)

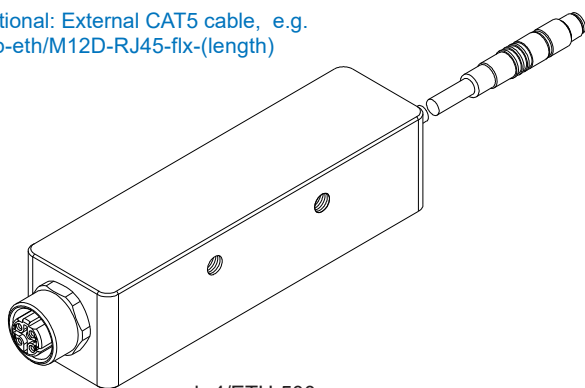

cab-4/ETH-500
 (length 0.5m, outer jacket: PUR)
 4-pole M12 fem. conn. (D-coded)
 for connection of an external
 CAT5 cable, e.g.
 cab-eth/M12D-RJ45-flx-(length)

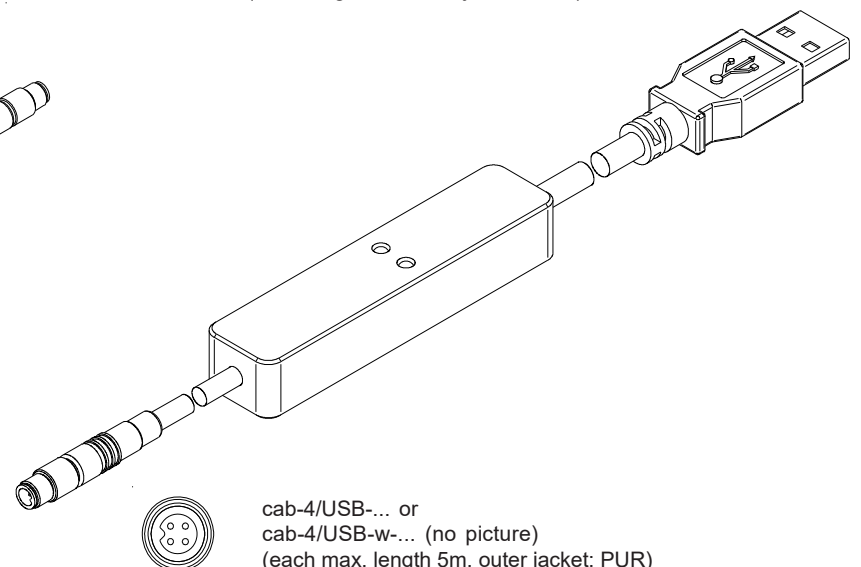

cab-4/USB-... or
 cab-4/USB-w-... (no picture)
 (each max. length 5m, outer jacket: PUR)

**Measuring Principle****Measuring Principle of the color sensors of SPECTRO-3-SLE series:**

The SPECTRO-3-...-SLE color sensor provides highly flexible signal acquisition. For example, the sensor can be operated in alternating-light mode (AC mode), which makes the sensor insensitive to extraneous light. It also can be set to constant-light mode (DC mode), which makes the sensor extremely fast. An OFF function turns off the integrated light source at the sensor and changes to DC operation. The sensor then can detect so-called "self-luminous objects". With the stepless adjustment of the integrated light source as well as the selectable gain of the receiver signal and an INTEGRAL function the sensor can be set to almost any surface or any "self-luminous object".

When the integrated light source of the SPECTRO-3-...-SLE color sensor is activated, the sensor detects the radiation that is diffusely reflected from the object. As a light source the SPECTRO-3-...-SLE color sensor uses a white-light LED with adjustable transmitter power. An integrated 3-fold receiver for the red, green, and blue content of the light that is reflected from the object, or the light that is emitted by a "self-luminous object", is used as a receiver.

As a light source the SPECTRO-3-UV-SLE or SPECTRO-3-FIO-UV-SLE color sensor uses a UV-LED (375 nm) with adjustable transmitter power to excite the luminescent marking. An integrated 3-fold receiver for the red, green, and blue content of the visible light that is emitted by the luminescent marking is used as a receiver. A special feature here is that the gain of the receiver can be set in 8 steps. This makes it possible to optimally adjust the sensor to almost any luminescent colorant that can be excited in the long-wave UV range.

The SPECTRO-3-...-SLE color sensor can be "taught" up to 31 colors, which are output directly via the outputs, and up to 64 colors which are output via color groups. For each of these taught colors it is possible to set tolerances. In "X Y INT - 2D" or "s i M - 2D" mode these tolerances form a color cylinder in space. In "X Y INT - 3D" or "s i M - 3D" mode the tolerances form a color sphere in space. Color evaluation according to "s i M - 2D" is based on the lab calculation method. All modes can be used in combination with several operating modes such as "FIRST HIT" and "BEST HIT". Raw data are represented with 12 bit resolution.

As a special feature the sensor can be taught two completely independent parameter sets. Input IN0 can be used to tell the sensor which parameter set it should work with.

Color detection either operates continuously or is started through an external PLC trigger signal. The respective detected color either is provided as a binary code at the 5 digital outputs or can be sent directly to the outputs, if only up to 5 colors are to be detected. Through input IN0 the color sensor can be taught up to 31 colors (64 colors in group mode). For this purpose the corresponding evaluation mode must be set with the software.

Parameters and measurement values can be exchanged between a PC and the SPECTRO-3-...-SLE color sensor through the serial RS232 interface. All the parameters for color detection also can be saved to the non-volatile EEPROM of the SPECTRO-3-...-SLE color sensor through this serial RS232 interface. When parameterisation is finished, the color sensor continues to operate with the current parameters in STAND-ALONE mode without a PC.

The sensors of the SPECTRO-3-...-SLE series can be calibrated (white-light balancing). Balancing can be performed to any white surface. A ColorChecker™ table with 24 color fields is available as an alternative. White-light balancing or calibration can be performed to one of the white, grey, or black fields.

The UV color sensors SPECTRO-3-UV-SLE and SPECTRO-3-FIO-UV-SLE also can be calibrated. Analogous to white-light balancing with color sensors, balancing of the SPECTRO-3-UV-SLE or SPECTRO-3-FIO-UV-SLE could be performed to any luminescent color marking.

Parameterization
Windows® user interface:

(The current software version is available for download on our website.)

The color sensor is parameterized under Windows® with the SPECTRO3-SLE-Scope software. The Windows® user interface facilitates the teach-in process at the color sensor and supports the operator in the task of adjustment and commissioning of the color sensor.

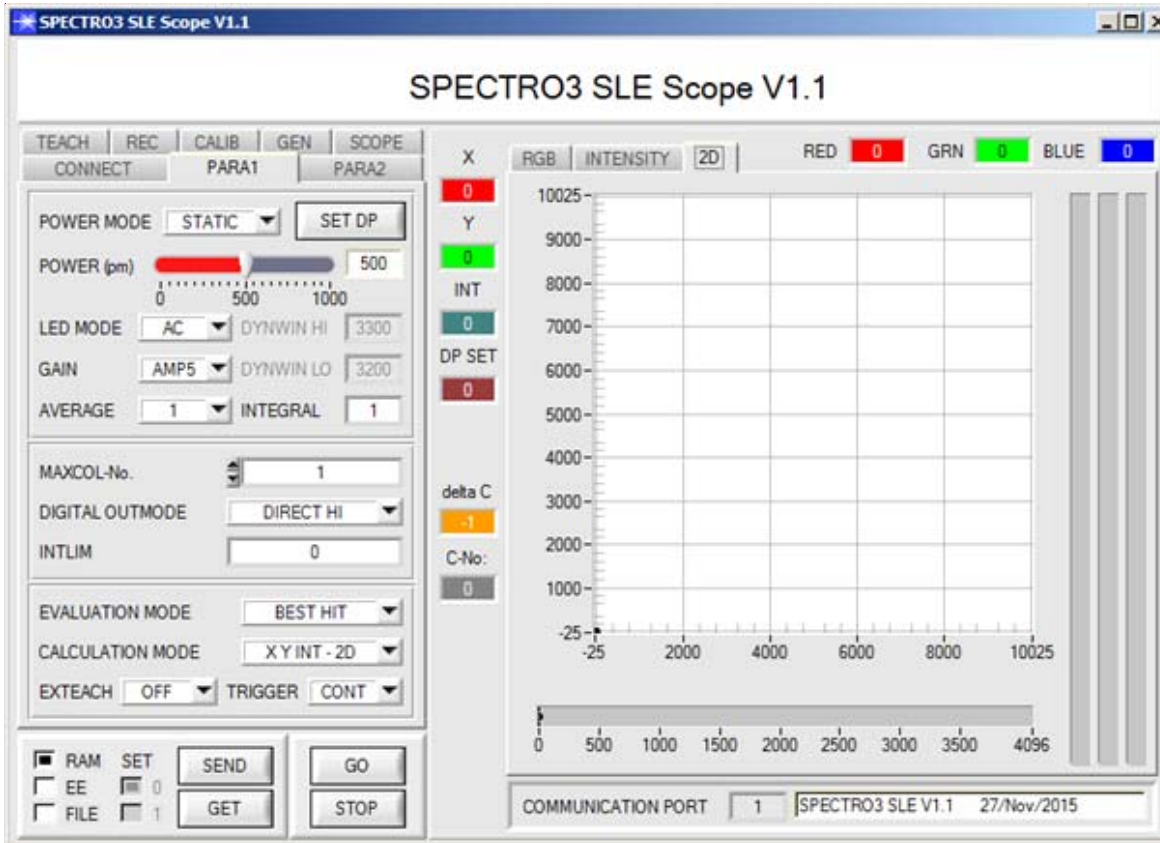

Under Windows® representation of the color value on a PC in numeric form and in a color chart, and representation of RGB values in a time chart. In addition the current RGB values are displayed as a bar chart.

The RS232 interface (tab PARA1 or PARA2) is used for setting parameters such as:

- POWER MODE: Light power of the LED
- SET DP: Setting of two parameter sets (Set Double Parameter)
- LED MODE: Triggering of the internal light source
- GAIN: Used for setting the gain of the receiver
- AVERAGE: Averaging over a maximum of 32768 values
- INTEGRAL: This function field is used to set the number of scan values (measurement values) over which the raw signal measured at the receiver is summed up. This integral function allows the reliable detection even of extremely weak signals
- MAXCOL-No.: Number of colors to be checked
- DIGITAL OUTMODE: Triggering of the digital outputs
- INTLIM: Minimum intensity required for color evaluation
- EVALUATION MODE: Various evaluation modes to choose from (FIRST HIT, BEST HIT, MIN DIST, COL5, THD RGB)
- CALCULATION MODE: There are 2 methods of teaching a color, which are selectable via CALCULATION MODE. The CALCULATION MODE „X Y INT - 3D“ (or „s i M - 3D“) uses a color sphere in space with radius TOL. Contrary to this, the CALCULATION MODE „X Y INT - 2D“ (or „s i M - 2D“) uses a color cylinder in space with radius CTO or siTO and with height ITO or M. The teach process is the same for both methods. Color evaluation according to "s i M - 2D" uses the Lab calculation method
- EXTEACH: In all the evaluation modes teaching of a color can be performed externally through INO
- TRIGGER: Continuous or external or self trigger

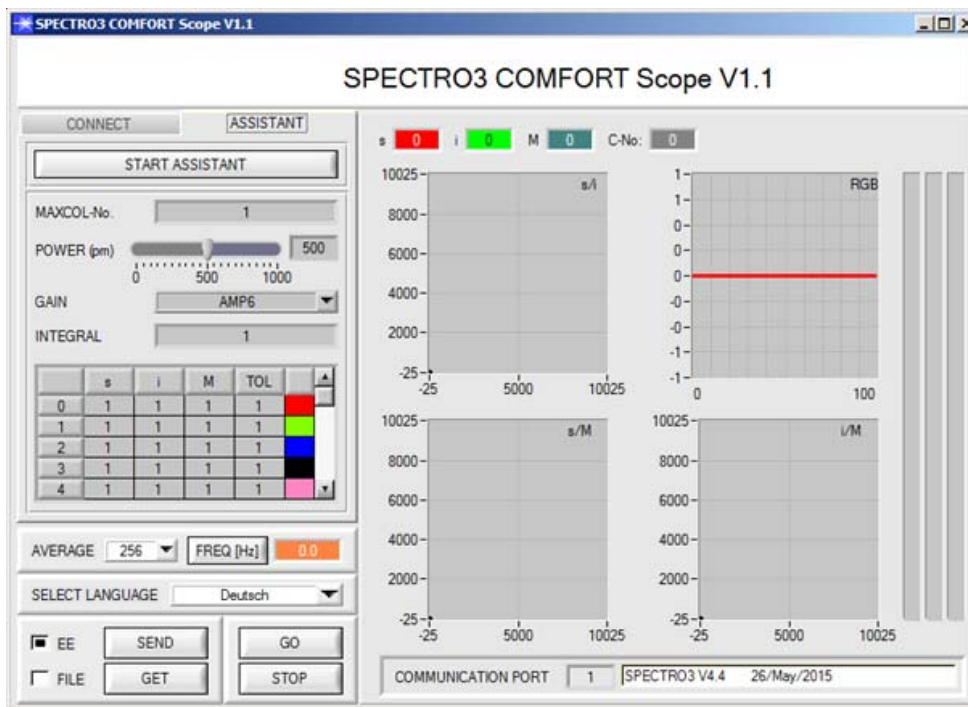

Parametrization
Windows® user interface SPECTRO3-COMFORT-Scope as an alternative to SPECTRO3-SLE-Scope:

Color sensors of the following types can be quickly parameterised with the SPECTRO3-COMFORT-SCOPE software:

SPECTRO-3 (im M34 housing)
 SPECTRO-3-CL
 SPECTRO-3-JR
 SPECTRO-3-SL
 SPECTRO-3-SLE

The software features menu guidance that prompts the user to enter all the relevant parameters.

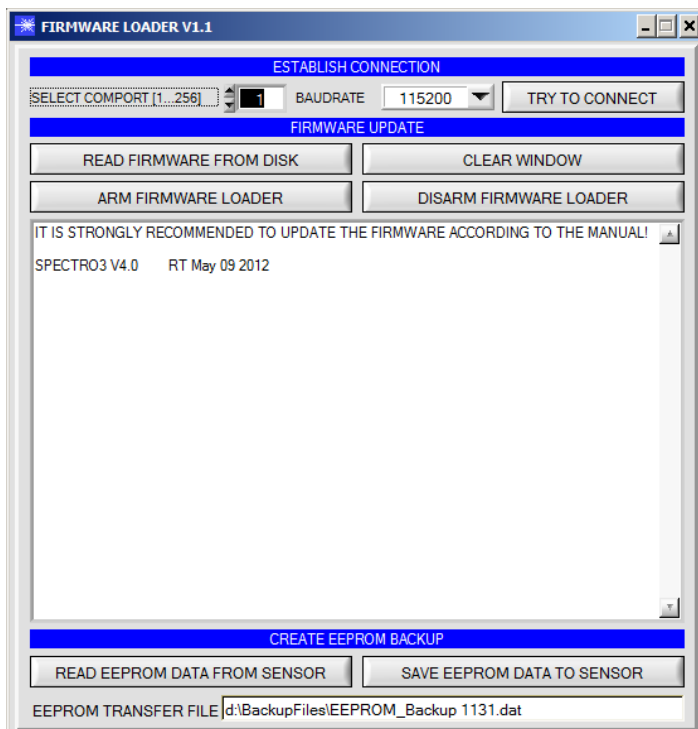

Firmware Update
Firmware update by means of the software „FirmwareLoader“:

The software „Firmware Loader“ allows the user to perform an automatic firmware update. The update will be carried out through the RS232 interface.

An initialisation file (xxx.ini) and a firmware file (xxx.elf.S) are required for performing a firmware update. These files can be obtained from your supplier. In some cases an additional firmware file for the program memory (xxx.elf.p.S) is also needed, and this file will be automatically provided together with the other two files.



POF Series

Plastic Optic Fibers

The plastic optic fibers of POF Series are used for **contactless detecting, counting, controlling, positioning** as well as **scanning of micro objects at processing stations, feed and automatic systems.**

- Big assortment of sensors (diffuse reflection or through-beam)
- Small sensing heads with different lines of sight (axial, angular, flexible)
- Trouble-free shortening of the plastic optic fibers
- Small bending radius, low weight
- Possible application in explosion-hazardous areas
- No interference by magnet or high-frequency fields (welding plants, switchgear et al.)
- Sturdy, flexible, vibration-proof
- For temperatures from -55°C to +80°C (or +350°C with HT type)



Characteristics:

Our plastic optic fiber systems consist of an optoelectronic fiber optic sensor (e.g. SPECTRO-1-POF, SPECTRO-1-POF-IR, SPECTRO-3-POF-SL, SPECTRO-3-POF-SLA, SPECTRO-3-POF-SLE) and a flexible plastic optic fiber with a sensing head.

The principle of operation is similar to a through-beam sensor or a diffuse reflection sensor.

The optoelectronic fiber optic sensor includes transmitter, receiver, evaluation electronics and amplifier. It uses e.g. white light or IR light, which is transmitted through the fiber by the principle of total internal reflection (see figure "reflection inside a plastic optic fiber").

We offer a wide choice of sensing heads that can be adapted to suit varying field conditions. E.g. as a diffuse reflection sensor or as a through-beam sensor with axial or radial light emission or with a 90mm flexible stainless steel sleeve which is even capable of „looking“ round corners, if needed.

The advantages of plastic optic fibers are the small bending radii. The fiber optics are bendable in any directions within the stated bending radii. It is also possible to cut the fibers in the field to any desired length using the fiber cutting tool (POF-CUTTER).

Order code:

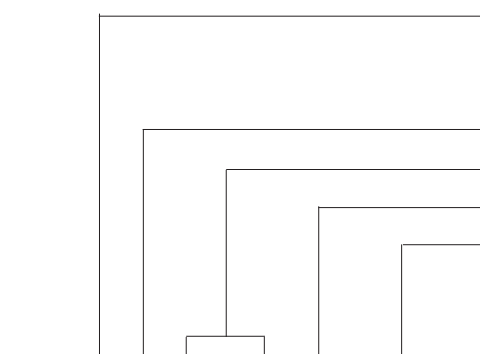

POF-D-80-d2.5/d1-(0.5)-2000

Order code plastic optic fibers (example)

(For detailed description of the various types of plastic optic fibers, please cf. catalog „POF Series“)

Function principle of the plastic optic fiber

(D = through-beam operation, D/90 = through-beam operation, angular 90°

R = reflective light operation, R/90 = reflective light operation, angular 90°)

Working range (scanning range) (in mm)

Sensor head type (e.g. d2.5/d1 = sensor head case style Ø 2.5mm and Ø 1mm)

Cross section of fiber bundle (in mm)

Total length of optic fiber (in mm)

Special versions:

-HT: Sensor head for use in applications with high temperature (up to 350°C)

-VA: Stainless steel sheathing (VA / SUS) of the optical fibers

-CSC: Cross section converter

-SPX: Simplex (plastic optic fiber in simple version without a sensor head)



(For detailed description of the various types of plast optic fibers, please cf. catalog „POF Series“)

Diffuse reflection sensors:

Reflective light fiber optics - optics axial

Catalog

POF-R-12-18x14x6-(0.5)-2000	page 4
POF-R-25-d4/d1.5-(1.1)-1000	page 4
POF-R-30-M6x0.75/d2.5-(1.0)-2000	page 5
POF-R-32-d3-(0.5)-2000	page 5
POF-R-32-M4/M3-(0.5)-2000	page 6
POF-R-35-d4/d3-(0.5)-2000	page 6
POF-R-35-M4/d3-(0.5)-2000	page 7
POF-R-40-M6x0.75/d4-(1.0)-2000	page 7
POF-R-45-M4/d2.5-(0.5)-2000	page 8
POF-R-55-M4/M3-(0.5)-2000	page 8
POF-R-60-M5x0.5-(0.5)-2000	page 9
POF-R-75-d6/d4-(1.0)-2000	page 9
POF-R-75-M6/d4.5-(1.0)-2000	page 10
POF-R-90-M4-(1.0)-2000	page 10
POF-R-110-20x20x5-(1.1)-2000	page 11
POF-R-110-d3-(1.0)-2000	page 11
POF-R-110-M6/d2.5-(1.1)-2000	page 12
POF-R-125-M3/d2-(0.5)-2000	page 12

POF-R-125-M4/d2.5-(0.5)-2000	page 13
POF-R-220-M6-(1.1)-2000	page 13
POF-R-230-15x9.5x5.2-(1.1)-2000	page 14
POF-R-400-M6/d4.5-(1.0)-2000	page 14

Reflective light fiber optics - high temperature resistant

POF-R-HT-M6x0.75/d4-(1.0)-2000-VA	page 15
---	---------

Reflective light fiber optics - optics angular 90°

POF-R/90-12-24x21x4-(0.5)-2000	page 16
POF-R/90-25-d3/d1.5-(0.5)-2000	page 16
POF-R/90-45-d5/d2-(1.1)-2000	page 17
POF-R/90-85-M8/d4-(1.0)-2000	page 17

Reflective light fiber optics - simplex:

POF-SPX1-d2.2-(1.0)-(length)	page 18
------------------------------------	---------

Through-beam sensors:

Through beam fiber optics - optics axial

Catalog

POF-D-40-d1-(0.5)-500	page 19
POF-D-80-15x15x5-(0.5)-2000	page 19
POF-D-100-d3/d1.5-(0.5)-2000	page 20
POF-D-100-d4/d3-(0.5)-2000	page 20
POF-D-100-M3/d2-(0.5)-2000	page 21
POF-D-100-M4/d1.2-(1.0)-2000	page 21
POF-D-120-M4/M2.6-(1.0)-2000	page 22
POF-D-140-d1.5-(0.5)-2000	page 22
POF-D-140-M3/d0.88-(0.5)-2000	page 23
POF-D-140-M3/d2-(0.5)-2000	page 23
POF-D-140-M4/M2.6-(1.0)-2000	page 24
POF-D-200-M4/d3-(1.0)-2000	page 24
POF-D-290-d3/d2-(1.1)-2000	page 25
POF-D-400-M4/d1.48-(1.0)-2000	page 25
POF-D-440-M4/d3-(1.0)-2000	page 26
POF-D-530-M4/M2.6-(1.0)-2000	page 26
POF-D-800-d2.5-(1.0)-2000	page 27
POF-D-1400-12x8x3-(0.5)-2000	page 27

POF-D-14000-M14-(1.0)-10000	page 28
-----------------------------------	---------

Through beam fiber optics - optics angular 90°

POF-D/90-100-d4-(1.0)-2000	page 28
POF-D/90-180-d2/d1-(1.0)-2000	page 29
POF-D/90-200-d2.5/d1.5-(1.0)-2000	page 29
POF-D/90-200-M4/d3-(1.0)-2000	page 30
POF-D/90-230-M4/M2.6-(1.0)-2000	page 30
POF-D/90-350-69x20x5-(1.1)-2000	page 31
POF-D/90-400-12x8.5x3-(0.5)-2000	page 31
POF-D/90-700-d4-(1.1)-2000	page 32
POF-D/90-800-12x8x3-(0.5)-2000	page 32
POF-D/90-1500-31x13.5x4.2-(1.1)-2000	page 33
POF-D/90-CSC-31x13.5x4.2-(2.2x11)-2000	page 34

Through beam fiber optics - simplex:

POF-SPX2-d2.2-(1.0)-(length)	page 35
------------------------------------	---------

Accessories:

Fiber cutting tool

Catalog

POF-CUTTER	page 35
------------------	---------

Reduction sleeve (included in scope of delivery)

POF-SLV-2.2/1.1	page 36
POF-SLV-2.2/1.3	page 36