

SPECTRO Series

► SPECTRO-3-FIO-UV/VIS-JR-HP

- Big working range: typ. 1 mm ... 500 mm (depends on fiber optics and attachment optics)
- Various UV light conducting fiber optics available
- Up to 31 colors can be stored
- RS232 interface (USB or Ethernet converter is available)
- UV-LED, 365 nm, modulated (AC-/DC-/PULSE-operation or OFF for luminous objects can be switched)
- Detection of different luminescent colors
- Insensitive to outside light (in AC- and PULSE-operation)
- Brightness correction can be activated (STAT/DYN)
- Scan frequency max. 35 kHz (in DC- or OFF-operation)
- Switching frequency max. 40 kHz
- TEACH via PC or PLC (external input)
- Various evaluation algorithms can be activated
- "BEST HIT" mode ("human color assessment")
- Parameterizable via Windows® software, scope function
- Temperature compensated
- Averaging can be activated (from 1 up to over 32000 values)
- 3-color filter detector (true color detector: "human color perception")
- Integrated cooling device for protection against overheating of the sensor

In Proud Partnership with Sensor Instruments

PAQUIN
SENSORS

For technical support, sales, & distribution
within the USA & Canada

www.paquin.com | (800) 831-8217 | paquinsensors@paquin.com



Design

Product range:

SPECTRO-3-FIO-UV/VIS-JR-HP

(incl. Windows® PC software SPECTRO3-Scope and SPECTRO3-COMFORT-Scope)

UV/VIS:

The transmitter here operates in the UV range, whereas the receiver operates in the visible range. Suitable fiber optics are available both for reflective and for through-beam operation. These fiber optics have quartz fibers at the transmitter side, and standard 67° fibers at the receiver side.

Accessories: (cf. p. 8-15)

UV fiber optics
Attachment optics
Offline units

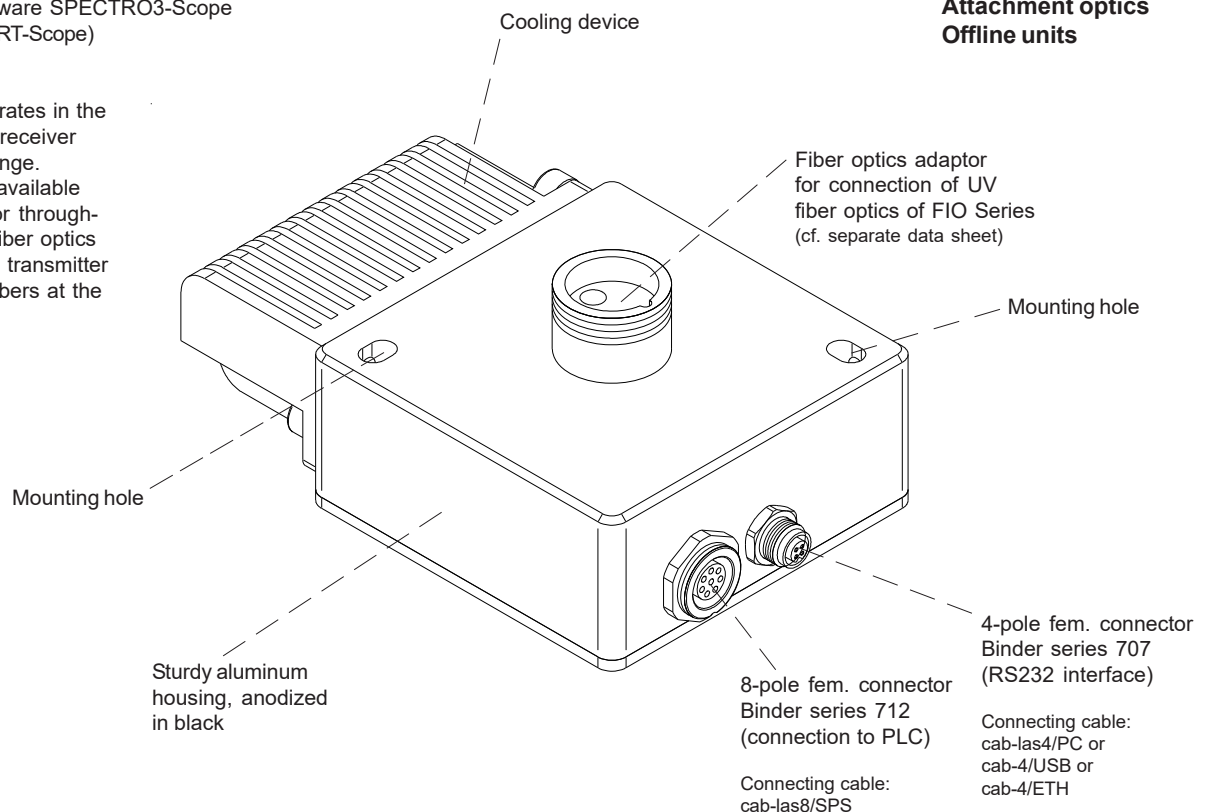



Technical Data

Model	SPECTRO-3-FIO-UV/VIS-JR-HP
Voltage supply	+24VDC ($\pm 10\%$), reverse polarity protected, overcurrent protected
Current consumption	< 160 mA
Max. switching current	100 mA, short circuit protected
Input digital (1x)	IN0 (Pin 3), digital (0V/+24V)
Outputs digital (5x)	OUT0 ... OUT4 (Pin 4 ... 8): digital (0V/+24V), npn-/pnp-able (bright-/dark-switching, can be switched)
Interface	RS232
Pulse lengthening	0 ... 100 ms, adjustable via PC software
Averaging	max. 32768 values, adjustable via PC software
Scan frequency	LED operation, can be switched via PC software: AC operation: max. 20 kHz (depends on parameterization) DC and OFF operation: max. 35 kHz (depends on parameterization) PULSE operation: max. 5 kHz (depends on parameterization)
Switching frequency	typ. 40 kHz
Transmitter (light source)	UV-LED, 365 nm
Transmitter control	can be switched via PC software: AC operation (LED MODE-AC), DC operation (LED MODE-DC), OFF operation (LED MODE-OFF) or PULSE operation (LED MODE-PULSE)
Object distance (measuring range)	with reflected light fiber optics: typ. 1 mm ... 500 mm (depends on fiber optics and optical frontend used) with transmitted light fiber optics: typ. 10 mm ... 500 mm (depends on fiber optics and optical frontend used)
Receiver	3-color filter detector (TRUE COLOR detector, "human color perception"), color filter curves acc. to CIE 1931
Receiver gain setting	8 steps (AMP1 ... AMP8), adjustable via PC software
Ambient light	max. 5000 Lux
Size of light spot	circular: typ. \varnothing 1.5 mm ... \varnothing 3 mm or rectangular: typ. 3 mm x 0.5 mm ... 6 mm x 1 mm depends on fiber optics and attachment optics (cf. catalog FIO series)
Reproducibility	in the X, Y color range each 1 digit at 12-bit A/D conversion
Temperature drift X,Y	$\Delta X/\Delta T$; $\Delta Y/\Delta T$ typ. 0,2 digits/ $^{\circ}\text{C}$ (< 0,01% / $^{\circ}\text{C}$)
Color difference	$\Delta E \geq 0,5$
Color space	X Y INT siM (Lab)
Color memory capacity	non-volatile EEPROM with parameter sets for max. 31 colors
Housing dimensions	LxWxH approx. 65 mm x 95 mm x 40 mm (incl. fiber optics adapter M18x1, without flange connectors)
Housing material	aluminum, anodized in black
Enclosure rating	IP64
Connecting cables	to PLC: cab-las8/SPS or cab-las8/SPS-w to PC/RS232 interface: cab-las4/PC or cab-las4/PC-w to PC/USB interface: cab-4/USB or cab-4/USB-w to PC/Ethernet interface: cab-4/ETH
Type of connector	connection to PLC: 8-pole fem. connector (Binder 712) connection to PC: 4-pole fem. connector (Binder 707)
Operating temp. range	-20 $^{\circ}\text{C}$... +55 $^{\circ}\text{C}$
Storage temperature range	-20 $^{\circ}\text{C}$... +85 $^{\circ}\text{C}$
EMC test acc. to	DIN EN 60947-5-2

Dimensions

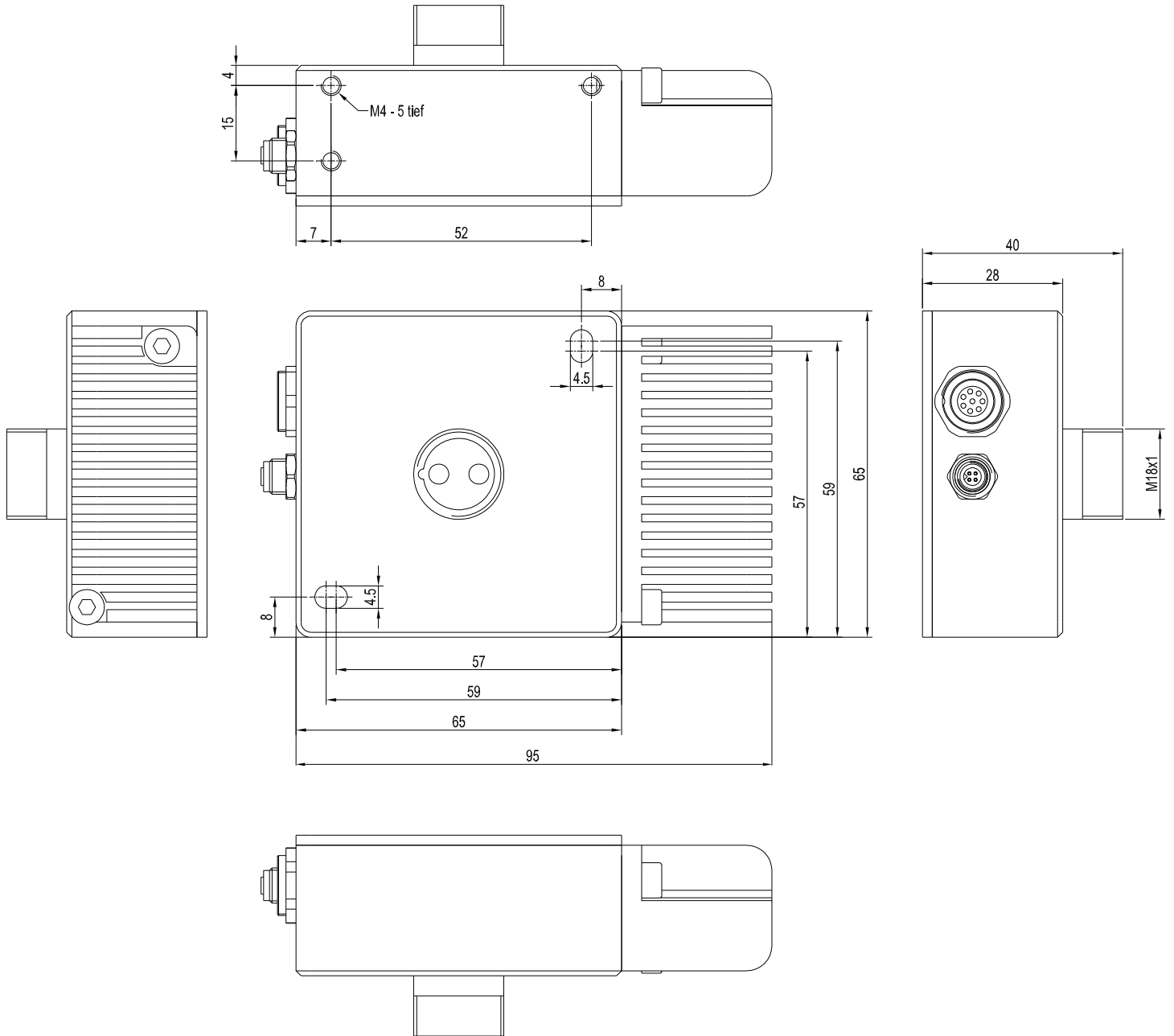

All dimensions in mm



Connector Assignment
Connection to PLC:**8-pole fem. connector Binder Series 712**

Pin:	Color:	Assignment:
1	white	GND (0V)
2	brown	+24VDC ($\pm 10\%$)
3	green	IN0
4	yellow	OUT0 (Digital 0: typ. 0...1V, Digital 1: typ. +Ub - 10%)
5	grey	OUT1 (Digital 0: typ. 0...1V, Digital 1: typ. +Ub - 10%)
6	pink	OUT2 (Digital 0: typ. 0...1V, Digital 1: typ. +Ub - 10%)
7	blue	OUT3 (Digital 0: typ. 0...1V, Digital 1: typ. +Ub - 10%)
8	red	OUT4 (Digital 0: typ. 0...1V, Digital 1: typ. +Ub - 10%)

Connecting cable:

cab-las8/SPS-(length)

cab-las8/SPS-w-(length) (angle type, 90°)

(standard length 2m)

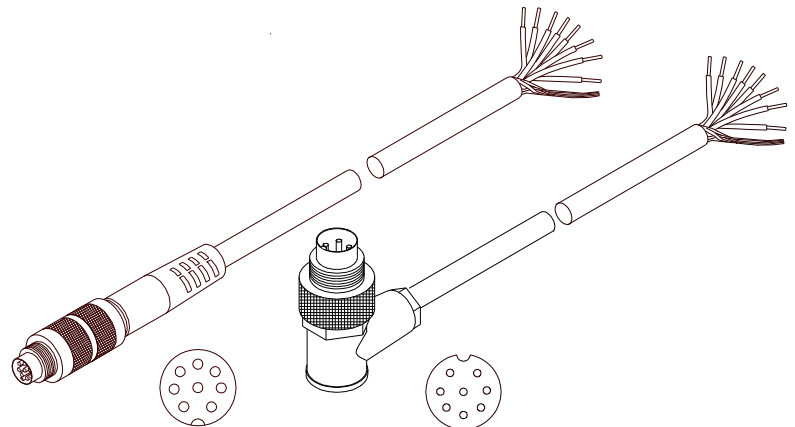
cab-las8/SPS-...
(max. length 25m, outer jacket: PUR)cab-las8/SPS-w-...
(max. length 25m, outer jacket: PUR)**Connection to PC:****4-pole fem. connector Binder Series 707**

Pin:	Assignment:
1	+24VDC (+Ub, OUT)
2	GND (0V)
3	RxD
4	TxD

Connection via RS232 interface at the PC:**Connecting cable:**

cab-las4/PC-(length)

cab-las4/PC-w-(length) (angle type 90°)

(standard length 2m)

alternative:**Connection via USB interface at the PC:**

USB converter (incl. driver software):

cab-4/USB-(length)

cab-4/USB-w-(length) (angle type 90°)

(standard length 2m)

alternative:**Connection to local network via Ethernet bus:**

Ethernet converter (incl. software „SensorFinder“):

cab-4/ETH-500

(standard length 0.5m)

Optional: External CAT5 cable, e.g.

cab-eth/M12D-RJ45-flx-(length)

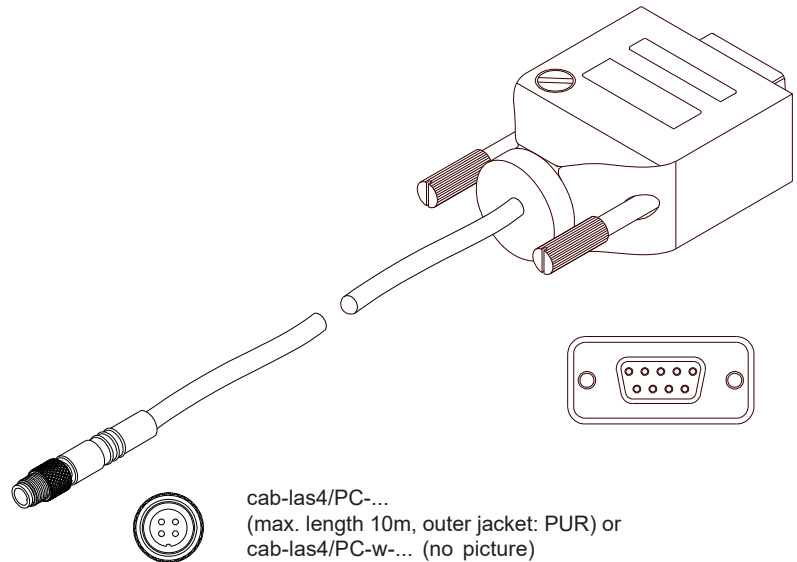
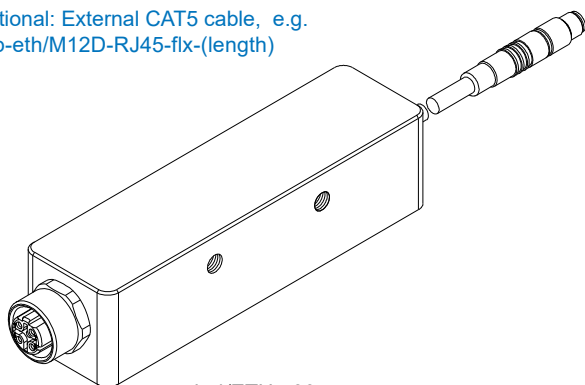
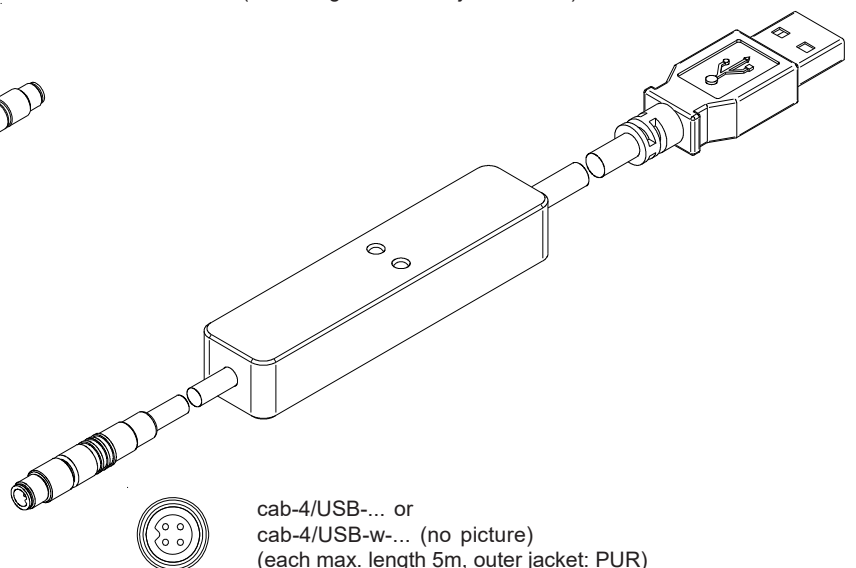
cab-las4/PC-...
(max. length 10m, outer jacket: PUR) or
cab-las4/PC-w-... (no picture)
(max. length 5m, outer jacket: PUR)cab-4/ETH-500
(length 0.5m, outer jacket: PUR)
4-pole M12 fem. conn. (D-coded)
for connection of an external
CAT5 cable, e.g.
cab-eth/M12D-RJ45-flx-(length)cab-4/USB-... or
cab-4/USB-w-... (no picture)
(each max. length 5m, outer jacket: PUR)



Measuring Principle

Measuring principle of color sensors of SPECTRO-3-...-UV series:

The SPECTRO-3 provides highly flexible signal acquisition. For example, the sensor can be operated in alternating-light mode (AC mode), which makes the sensor insensitive to extraneous light. It also can be set to constant-light mode (DC mode), which makes the sensor extremely fast and allows a scan-frequency of up to 35 kHz.

When the integrated light source of the SPECTRO-3-...-UV color sensor is activated, the sensor detects the radiation that is diffusely reflected from the object to be measured.

As a light source the SPECTRO-3-...-UV color sensor uses a UV-LED (375 nm, or 365 nm in case of using an external UV illumination unit SPECTRO-ELS-UV) with adjustable transmitter power to excite the luminescent marking. An integrated 3-fold receiver for the red, green, and blue content of the visible light that is emitted by the luminescent marking is used as a receiver. A special feature here is that the gain of the receiver can be set in 8 steps. This makes it possible to optimally adjust the sensor to almost any luminescent colorant that can be excited in the long-wave UV range (365 nm or 375 nm).

The SPECTRO-3 color sensor can be "taught" up to 31 colors. For each of these taught colors it is possible to set tolerances. In X/Y INT or s/i M mode these tolerances form a color cylinder in space. In X/Y/INT or s/i/M mode the tolerances form a color sphere in space. Color evaluation according to s/i M is based on the lab calculation method. All modes can be used in combination with several operating modes such as "FIRST HIT" and "BEST HIT". Raw data are represented with 12 bit resolution.

As a special feature the sensor can be taught two completely independent parameter sets. Input IN0 can then be used to tell the sensor which parameter set it should work with.

Color detection either operates continuously or is started through an external PLC trigger signal. The respective detected color either is provided as a binary code at the 5 digital outputs or can be sent directly to the outputs, if only up to 5 colors are to be detected. At the same time the detected color code is visualised by means of 5 LEDs at the housing of the SPECTRO-3. [\[Please note: Visualisation by means of LEDs not available with SPECTRO-3-...-JR types.\]](#)

With a TEACH button at the sensor housing the color sensor can be taught up to 31 colors. For this purpose the corresponding evaluation mode must be set with the software. The TEACH button is connected in parallel to the input IN0 (green wire at cable cab-las8/SPS). [\[Please note: TEACH button not available with SPECTRO-3-...-JR types.\]](#)

Parameters and measurement values can be exchanged between a PC and the SPECTRO-3 color sensor through the serial RS232 interface. All the parameters for color detection also can be saved to the non-volatile EEPROM of the SPECTRO-3 color sensor through this serial RS232 interface. When parameterisation is finished, the color sensor continues to operate with the current parameters in STAND-ALONE mode without a PC.

The sensors of the SPECTRO-3-...-UV series also can be calibrated. Analogous to white-light balancing with color sensors, balancing of the SPECTRO-3-...-UV could be performed to any luminescent color marking.

Parameterization
Windows® user interface:

(The current software version is available for download on our website.)

The color sensor is parameterized under Windows® with the SPECTRO3-Scope software. The Windows® user interface facilitates the teach-in process at the color sensor and supports the operator in the task of adjustment and commissioning of the color sensor. Moreover, the software features a data recorder function that allows the automatic recording of recorded data and the saving of those at the hard disk of the PC.

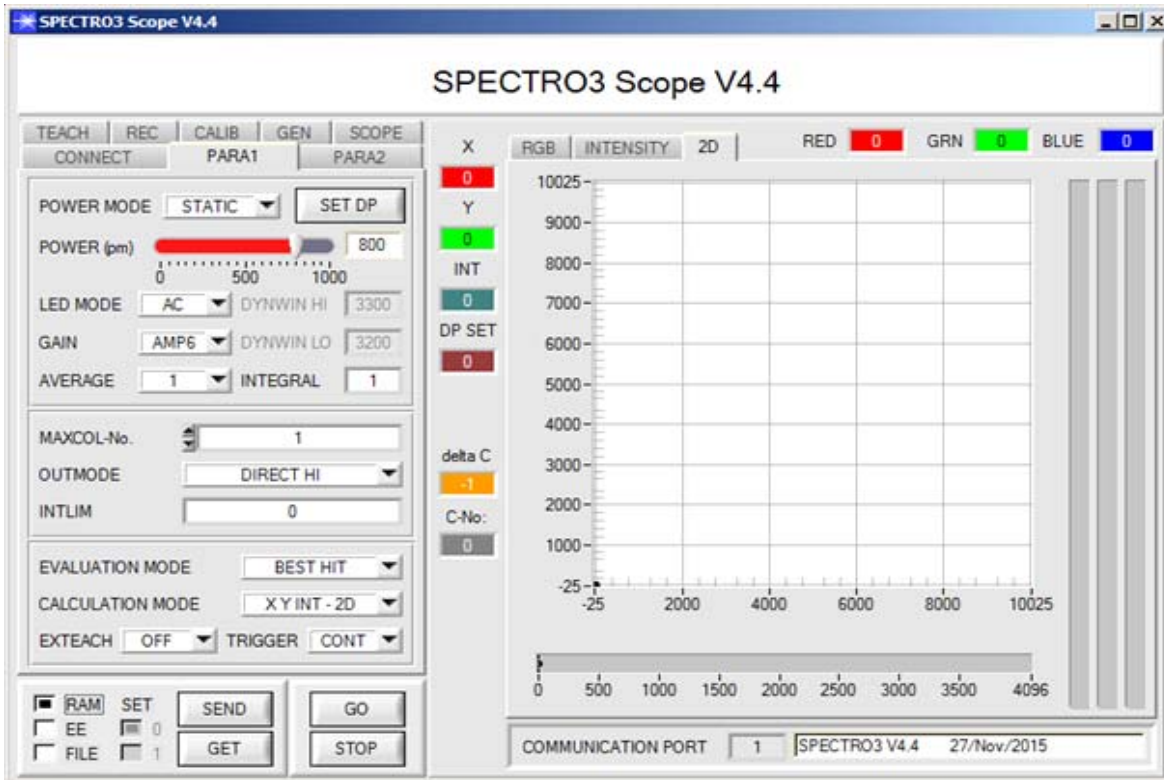

Under Windows® representation of the color value on a PC in numeric form and in a color chart, and representation of RGB values in a time chart. In addition the current RGB values are displayed as a bar chart.

Parameters and measurement values can be exchanged between PC and sensor either through RS232 or Ethernet (using an Ethernet adaptor). Through the interface all the parameters can be stored in the non-volatile EEPROM of the sensor. Tab PARA1 and PARA2 are used for setting parameters such as:

- POWER MODE: Light power of the LED
- LED MODE: Triggering of the internal light source
- GAIN: Used for setting the gain of the receiver
- AVERAGE: Averaging over a maximum of 32768 values
- INTEGRAL: This function field is used to set the number of scan values (measurement values) over which the raw signal measured at the receiver is summed up. This integral function allows the reliable detection even of extremely weak signals
- MAXCOL-No.: Number of colors to be checked
- OUTMODE: Triggering of the digital outputs
- INTLIM: Minimum intensity required for color evaluation
- EVALUATION MODE: Various evaluation modes to choose from (FIRST HIT, BEST HIT, MIN DIST, COL5, THD RGB)
- CALCULATION MODE: There are 2 methods of teaching a color, which are selectable via CALCULATION MODE. The CALCULATION MODE „X Y INT - 3D“ (or „s i M - 3D“) uses a color sphere in space with radius TOL. Contrary to this, the CALCULATION MODE „X Y INT - 2D“ (or „s i M - 2D“) uses a color cylinder in space with radius CTO or siTO and with height ITO or M. The teach process is the same for both methods. Color evaluation according to „s i M - 2D“ uses the Lab calculation method
- EXTEACH: In all the evaluation modes teaching of a color can be performed externally through IN0 or by means of the button at the sensor housing [Please note: TEACH button not available with SPECTRO-3-...-JR types.]
- TRIGGER: Continuous or external or self trigger

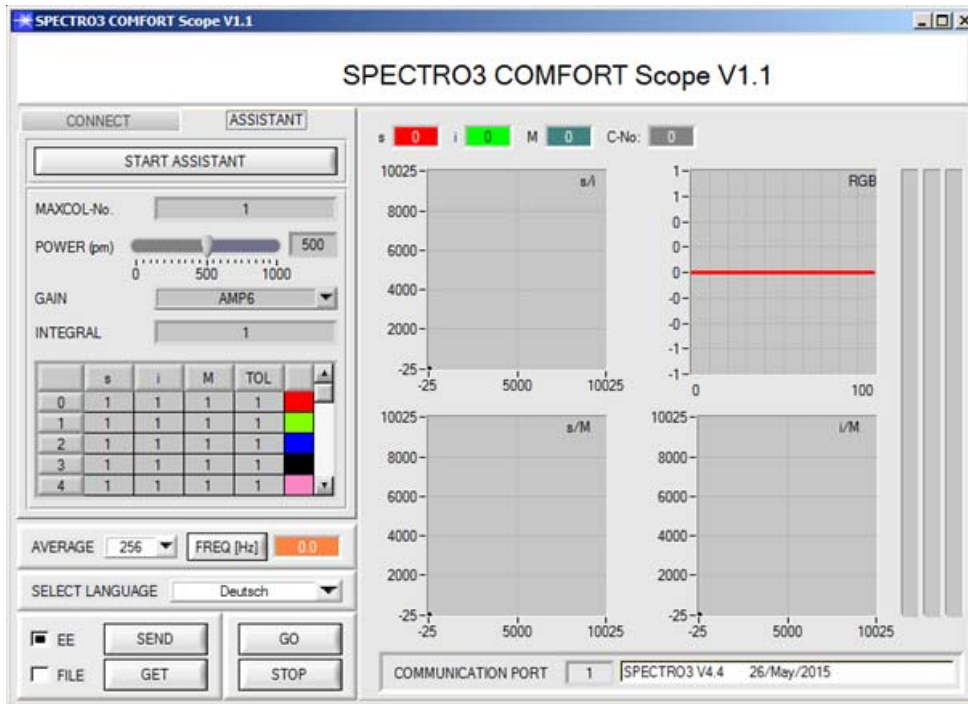

Parametrization
Windows® user interface SPECTRO3-COMFORT-Scope as an alternative to SPECTRO3-Scope:

Color sensors of the following types can be quickly parameterised with the SPECTRO3-COMFORT-SCOPE software:

SPECTRO-3 (im M34 housing)
 SPECTRO-3-CL
 SPECTRO-3-JR
 SPECTRO-3-SL
 SPECTRO-3-SLE

The software features menu guidance that prompts the user to enter all the relevant parameters.

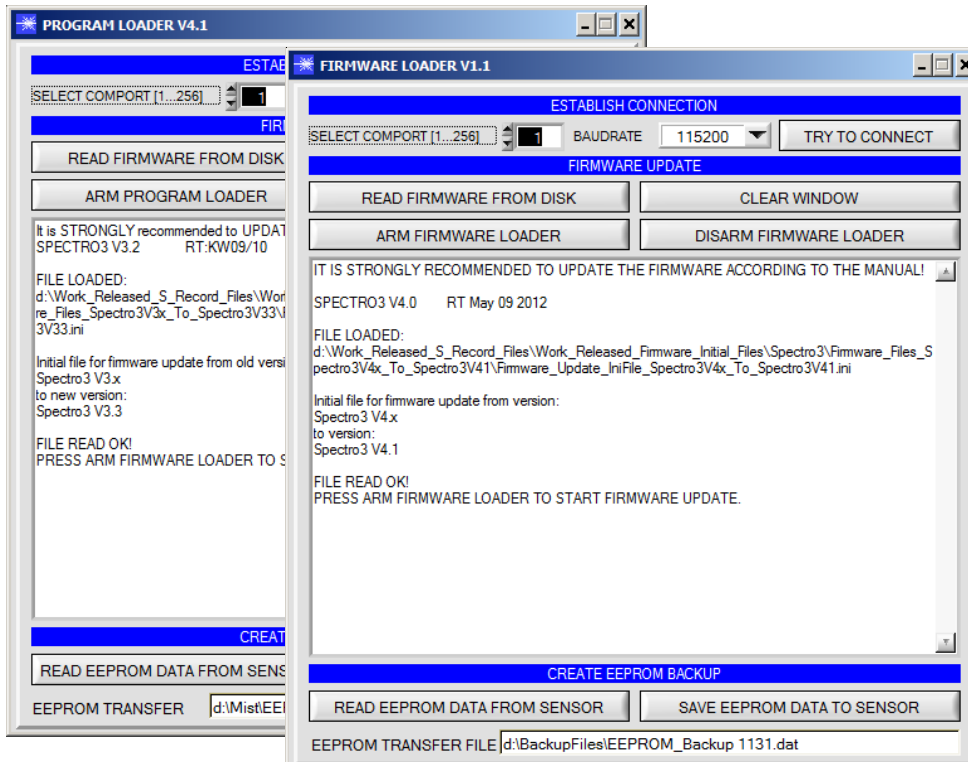

Firmware Update
Firmware update by means of software „ProgramLoader“ or „FirmwareLoader“:

The software „ProgramLoader“ or „FirmwareLoader“ allows the user to perform an automatic firmware update. The update will be carried out through the RS232 interface.

An initialisation file (xxx.ini) and a firmware file (xxx.elf.S) are required for performing a firmware update. These files can be obtained from your supplier. In some cases an additional firmware file for the program memory (xxx.elf.p.S) is also needed, and this file will be automatically provided together with the other two files.



UV Fiber Optics

Available standard-UV fiber optics types:

Reflected light UV fiber optics:

- R-S-A1.1-(1.5)-600-22°-UV
- R-S-A1.1-(1.5)-1200-22°-UV
- R-S-A2.0-(2.5)-600-22°-UV
- R-S-A2.0-(2.5)-1200-22°-UV
- R-S-A3.0-(3.0)-600-22°-UV
- R-S-A3.0-(3.0)-1200-22°-UV
- R-S-R1.1-(3x0.5)-600-22°-UV
- R-S-R1.1-(3x0.5)-1200-22°-UV
- R-S-R2.1-(6x1)-600-22°-UV
- R-S-R2.1-(6x1)-1200-22°-UV

Transmitted light UV fiber optics:

- D-P-B3.0-(2.5)-600-22°-UV
- D-S-A2.0-(2.5)-600-22°-UV
- D-S-A3.0-(3.0)-600-22°-UV

(further fiber optics types or lengths available on request)



Characteristics:

Light-conducting glass fibers are optical components that allow the transmission of light through any curved path based on the principle of total reflection. The individual fiber is composed of high-break core glass and low-break cladding glass. The light beams entering the core glass within the critical angle are guided through the fiber by way of reflection at the core/cladding contact surfaces (step index fiber). The highly flexible optical fibers are made of bundled individual glass fibers. The ends are each glued into a sensor head and a connector. The faces are optically polished. For protection against mechanical, chemical, or thermal destruction the optical fibers are provided with a corresponding protective sheath.

Order Code:

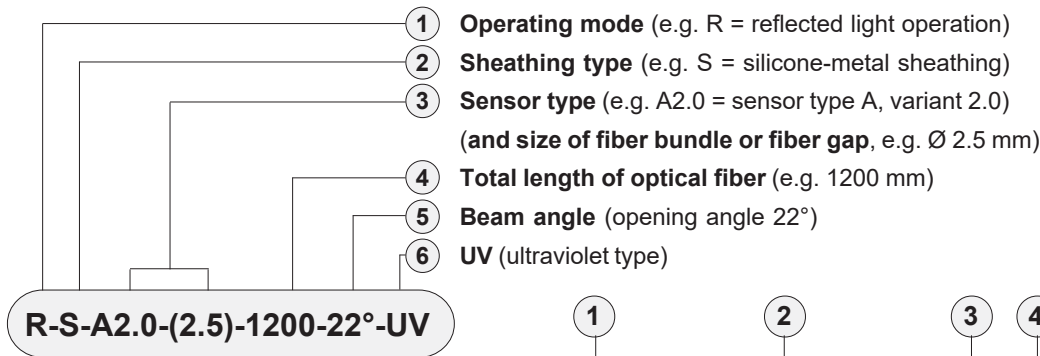

R-S-A2.0-(2.5)-1200-22°-UV

Order code for optical fiber

(For detailed description of the various types of fiber optics please cf. catalog „FIO Series“)

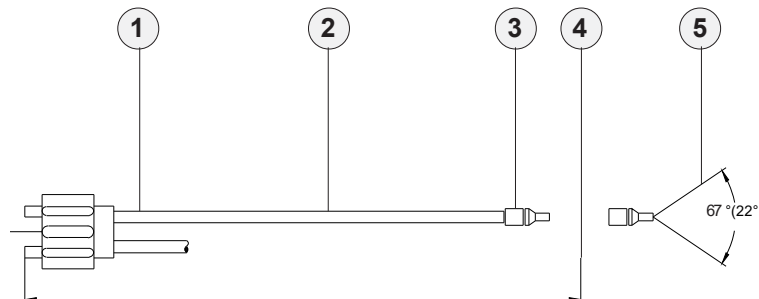

Dimensions of adapter

Attachment optics (e.g. focus lens, reflex optics, prism optics)

Fiber optics for reflex light operation

Fiber optics for transmitted light operation

Mounting hints

cf. catalog FIO Series
 cf. catalog FIO Series
 cf. catalog FIO Series
 cf. catalog FIO Series
 cf. catalog FIO Series



Optical Frontends

Overview: Optical frontends for reflected light UV fiber optics



KL-3-A2.0
KL-4-A1.1
KL-5-R1.1
KL-8-R2.1
KL-9-A3.0



KL-M8-A1.1



KL-M12-A1.1
KL-M12-A2.0
KL-M12-A3.0
KL-M12-R1.1



KL-M12-XL-A1.1
KL-M12-XL-A2.0
KL-M12-XL-R1.1



KL-M18-A1.1
KL-M18-A2.0
KL-M18-A3.0
KL-M18-R1.1
KL-M18-R2.1



KL-M18-XL-A1.1
KL-M18-XL-A2.0
KL-M18-XL-A3.0
KL-M18-XL-R1.1
KL-M18-XL-R2.1



KL-M34-A1.1
KL-M34-A2.0
KL-M34-A3.0
KL-M34-R1.1
KL-M34-R2.1



KL-M34-XL-A1.1
KL-M34-XL-A2.0
KL-M34-XL-A3.0
KL-M34-XL-R1.1
KL-M34-XL-R2.1



KL-M34/62-A1.1
KL-M34/62-A2.0
KL-M34/62-A3.0
KL-M34/62-R1.1
KL-M34/62-R2.1



Optical Frontends

Optical frontends for UV fiber optics (22°-UV):

Part number:	Suitable for UV fiber optics type: (R = reflected light)	Characteristics:
KL-3-A2.0	R-S-A2.0-(2.5)-1200-22°-UV	Working distance typ. 10 mm ... 20 mm
KL-4-A1.1	R-S-A1.1-(1.5)-1200-22°-UV	Working distance typ. 10 mm ... 15 mm
KL-5-R1.1	R-S-R1.1-(3x0.5)-1200-22°-UV	Working distance typ. 8 mm ... 20 mm
KL-8-R2.1	R-S-R2.1-(6x1)-1200-22°-UV	Working distance typ. 8 mm ... 25 mm
KL-9-A3.0	R-S-A3.0-(3.0)-1200-22°-UV	Working distance typ. 8 mm ... 25 mm
KL-M8-A1.1	R-S-A1.1-(1.5)-1200-22°-UV	Working distance typ. 8 mm ... 20 mm
KL-M12-A1.1	R-S-A1.1-(1.5)-1200-22°-UV	Working distance typ. 8 mm ... 20 mm
KL-M12-A2.0	R-S-A2.0-(2.5)-1200-22°-UV	Working distance typ. 8 mm ... 20 mm
KL-M12-A3.0	R-S-A3.0-(3.0)-1200-22°-UV	Working distance typ. 8 mm ... 20 mm
KL-M12-R1.1	R-S-R1.1-(3x0.5)-1200-22°-UV	Working distance typ. 8 mm ... 20 mm
KL-M12-XL-A1.1	R-S-A1.1-(1.5)-1200-22°-UV	Working distance typ. 30 mm ... 200 mm
KL-M12-XL-A2.0	R-S-A2.0-(2.5)-1200-22°-UV	Working distance typ. 30 mm ... 200 mm
KL-M12-XL-R1.1	R-S-R1.1-(3x0.5)-1200-22°-UV	Working distance typ. 30 mm ... 200 mm
KL-M18-A1.1	R-S-A1.1-(1.5)-1200-22°-UV	Working distance typ. 10 mm ... 60 mm
KL-M18-A2.0	R-S-A2.0-(2.5)-1200-22°-UV	Working distance typ. 10 mm ... 80 mm
KL-M18-A3.0	R-S-A3.0-(3.0)-1200-22°-UV	Working distance typ. 10 mm ... 80 mm
KL-M18-R1.1	R-S-R1.1-(3x0.5)-1200-22°-UV	Working distance typ. 10 mm ... 60 mm
KL-M18-R2.1	R-S-R2.1-(6x1)-1200-22°-UV	Working distance typ. 10 mm ... 80 mm
KL-M18-XL-A1.1	R-S-A1.1-(1.5)-1200-22°-UV	Working distance typ. 50 mm ... 300 mm
KL-M18-XL-A2.0	R-S-A2.0-(2.5)-1200-22°-UV	Working distance typ. 50 mm ... 300 mm
KL-M18-XL-A3.0	R-S-A3.0-(3.0)-1200-22°-UV	Working distance typ. 50 mm ... 300 mm
KL-M18-XL-R1.1	R-S-R1.1-(3x0.5)-1200-22°-UV	Working distance typ. 50 mm ... 300 mm
KL-M18-XL-R2.1	R-S-R2.1-(6x1)-1200-22°-UV	Working distance typ. 50 mm ... 300 mm
KL-M34-A1.1	R-S-A1.1-(1.5)-1200-22°-UV	Working distance typ. 50 mm ... 200 mm
KL-M34-A2.0	R-S-A2.0-(2.5)-1200-22°-UV	Working distance typ. 50 mm ... 250 mm
KL-M34-A3.0	R-S-A3.0-(3.0)-1200-22°-UV	Working distance typ. 50 mm ... 300 mm
KL-M34-R1.1	R-S-R1.1-(3x0.5)-1200-22°-UV	Working distance typ. 50 mm ... 200 mm
KL-M34-R2.1	R-S-R2.1-(6x1)-1200-22°-UV	Working distance typ. 50 mm ... 300 mm
KL-M34-XL-A1.1	R-S-A1.1-(1.5)-1200-22°-UV	Working distance typ. 50 mm ... 400 mm
KL-M34-XL-A2.0	R-S-A2.0-(2.5)-1200-22°-UV	Working distance typ. 50 mm ... 400 mm
KL-M34-XL-A3.0	R-S-A3.0-(3.0)-1200-22°-UV	Working distance typ. 50 mm ... 400 mm
KL-M34-XL-R1.1	R-S-R1.1-(3x0.5)-1200-22°-UV	Working distance typ. 50 mm ... 400 mm
KL-M34-XL-R2.1	R-S-R2.1-(6x1)-1200-22°-UV	Working distance typ. 50 mm ... 400 mm
KL-M34/62-A1.1	R-S-A1.1-(1.5)-1200-22°-UV	Working distance typ. 80 mm ... 200 mm
KL-M34/62-A2.0	R-S-A2.0-(2.5)-1200-22°-UV	Working distance typ. 80 mm ... 200 mm
KL-M34/62-A3.0	R-S-A3.0-(3.0)-1200-22°-UV	Working distance typ. 80 mm ... 200 mm
KL-M34/62-R1.1	R-S-R1.1-(3x0.5)-1200-22°-UV	Working distance typ. 80 mm ... 200 mm
KL-M34/62-R2.1	R-S-R2.1-(6x1)-1200-22°-UV	Working distance typ. 80 mm ... 200 mm



Accessories

A3.0-OFL (offline unit for fiber optics type A3.0)

(please order separately)

for use with reflected light fiber optics

R-S-A3.0-(3.0)-...-67° or

R-S-A3.0-(3.0)-...-22°-UV

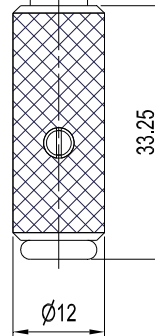
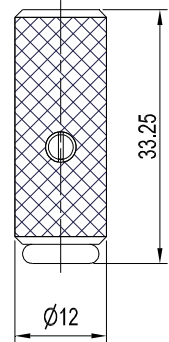
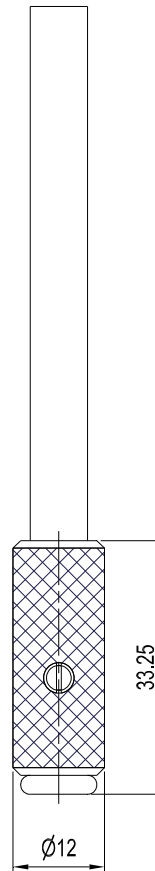
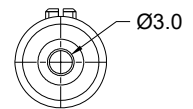
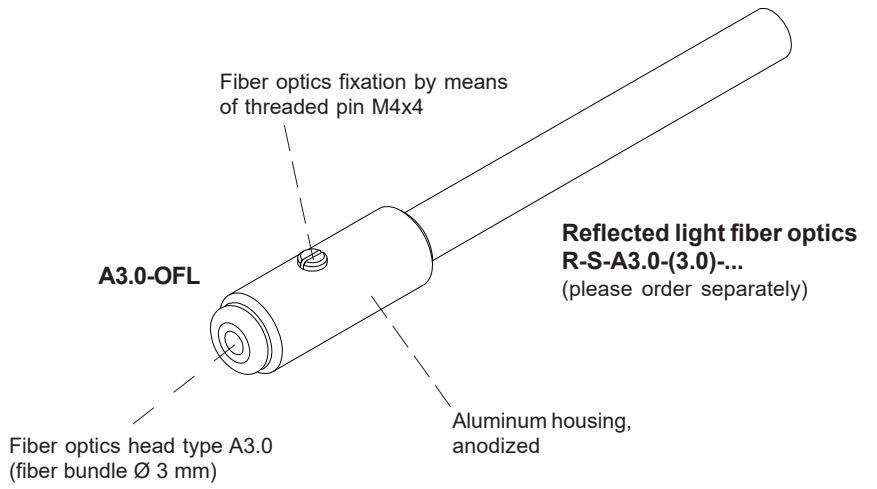

(All dimensions in mm)



Accessories

A3.0-OFL-10 (offline unit for fiber optics type A3.0)
(please order separately)

for use with reflected light fiber optics
R-S-A3.0-(3.0)-...-67° or
R-S-A3.0-(3.0)-...-22°-UV



A3.0-OFL-10

Fiber optics fixation by means of threaded pin M4x6

**Reflected light fiber optics
R-S-A3.0-(3.0)-...**
(please order separately)

Aluminum housing, anodized

Fiber optics head type A3.0
(fiber bundle Ø 3 mm),
offset 10 mm inwards

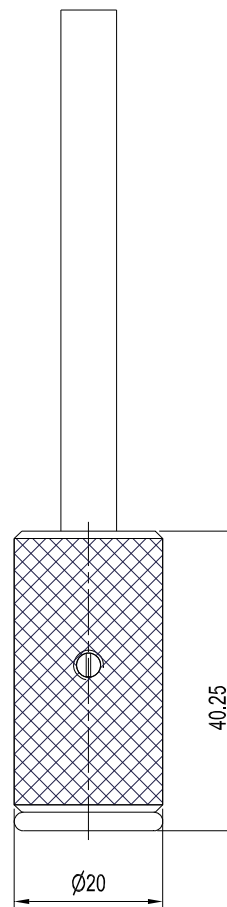
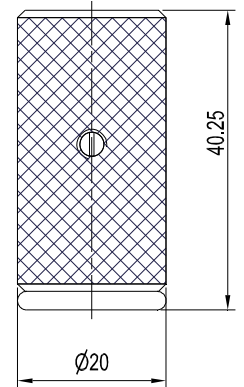
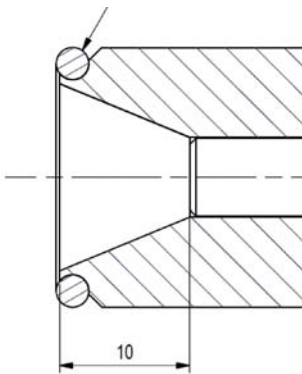
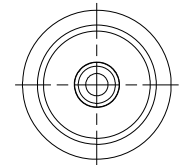
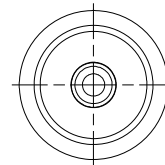

(All dimensions in mm)



Accessories

A3.0-OFL-SHIFT (offline unit for fiber optics type A3.0)
(please order separately)

For use with reflected light fiber optics
R-S-A3.0-(3.0)-...-67° or
R-S-A3.0-(3.0)-...-22°-UV

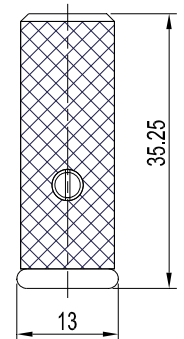
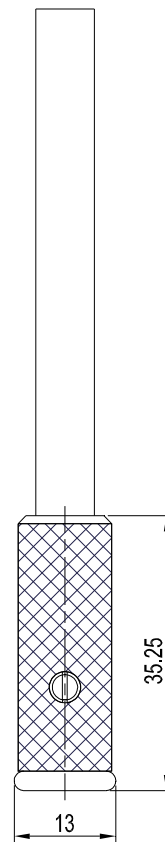
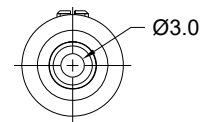
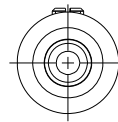
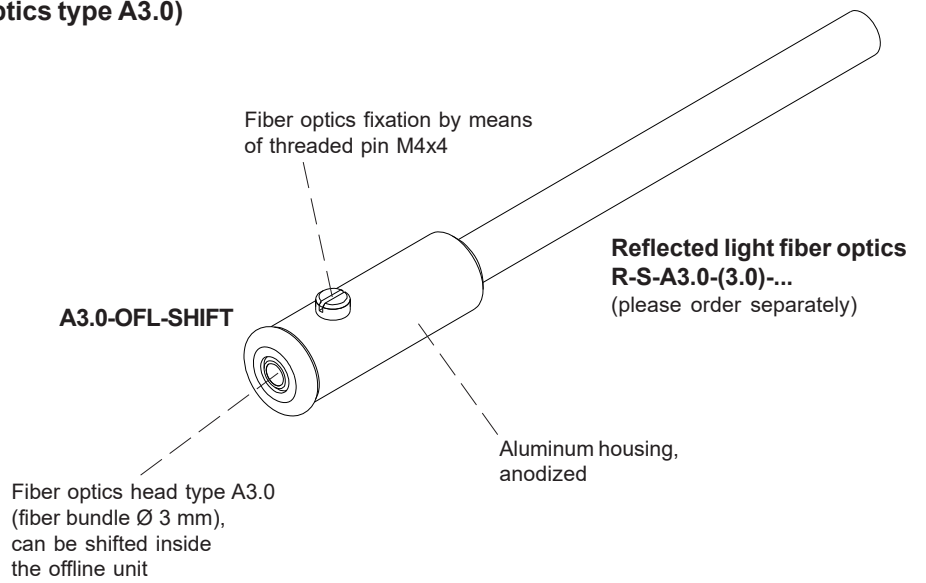

(All dimensions in mm)



Accessories

A3.0-OFL-D17-SHIFT (offline unit for fiber optics type A3.0)

(please order separately)

For use with reflected light fiber optics
 R-S-A3.0-(3.0)-...-67° or
 R-S-A3.0-(3.0)-...-22°-UV

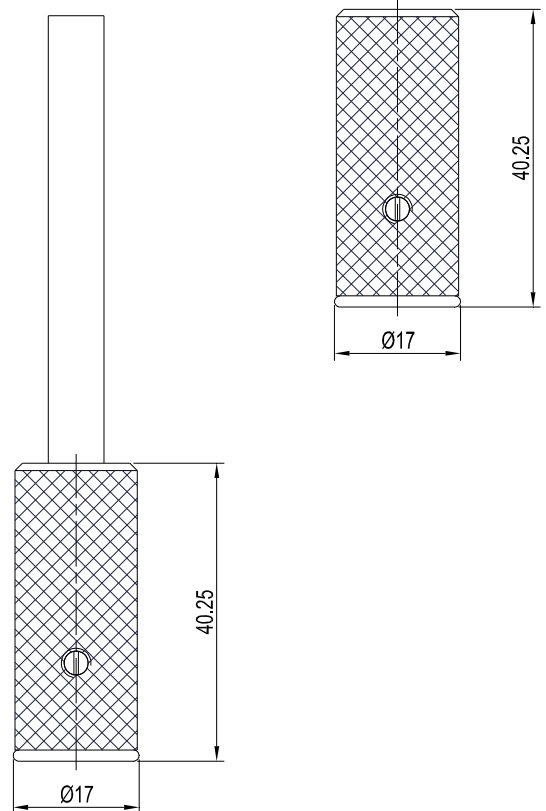
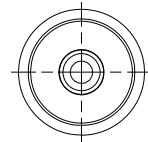
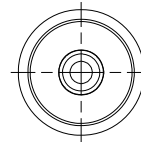
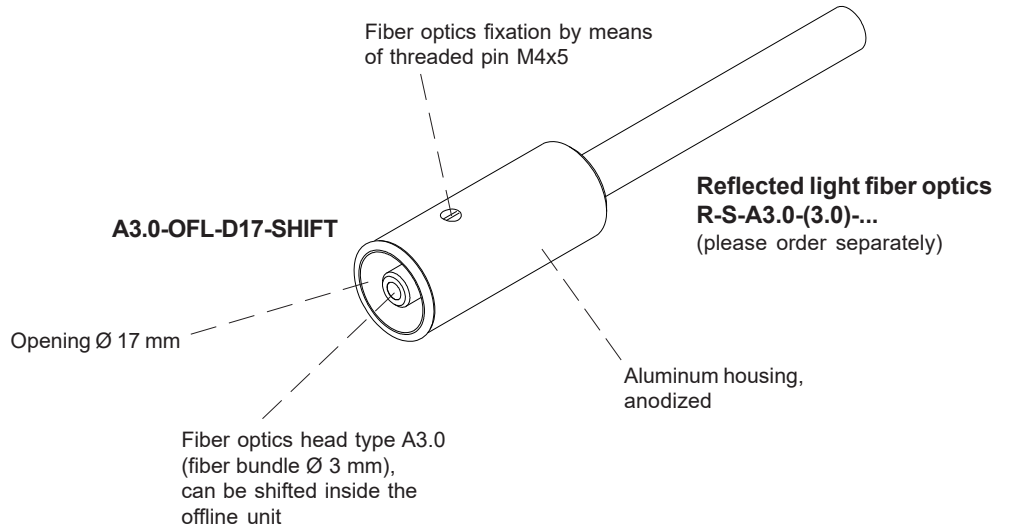

(All dimensions in mm)



Accessories

A3.0-OFL-D14/6 (offline unit for fiber optics type A3.0)

(please order separately)

For use with reflected light fiber optics
R-S-A3.0-(3.0)-...-67° or
R-S-A3.0-(3.0)-...-22°-UV

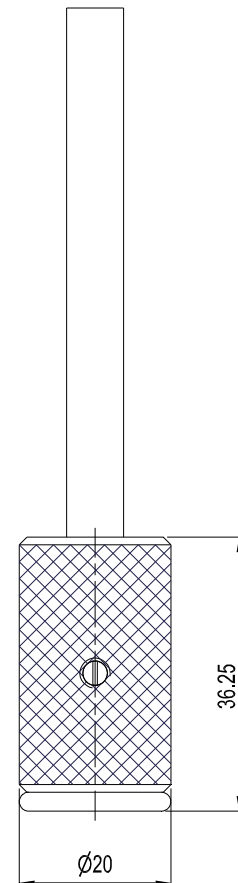
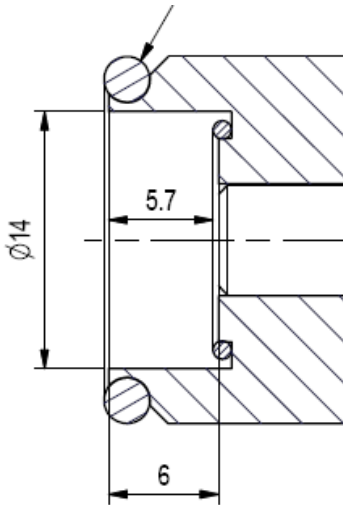
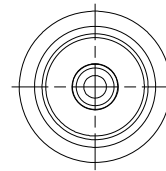
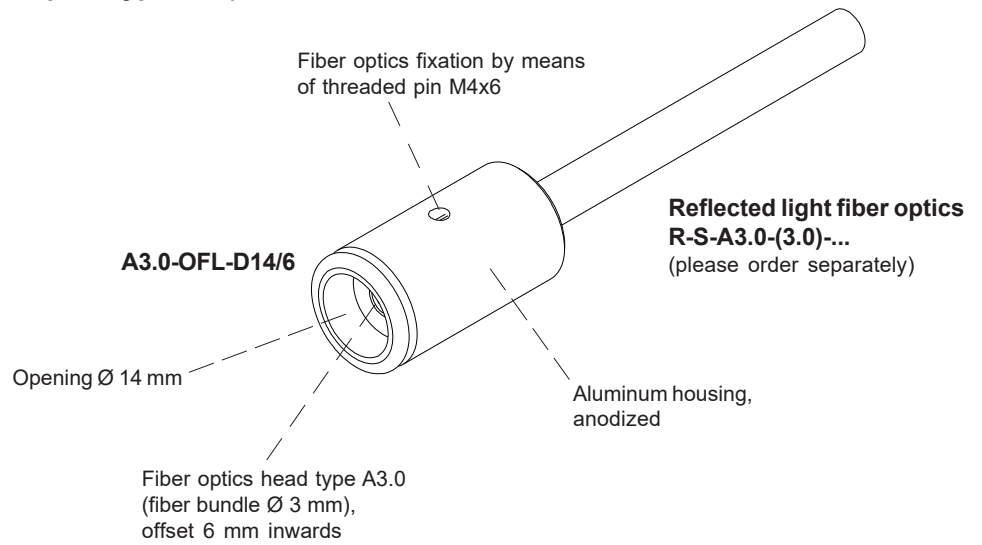

(All dimensions in mm)