

TLB Series

In Proud Partnership with Sensor Instruments



For technical support, sales, & distribution
within the USA & Canada

www.paquin.com | (800) 831-8217 | paquinsensors@paquin.com



▶ SLB-01 Split light barriers

- Insensitive to outside light due to optical filtering
- Connection either to constant light amplifier or pulsating light amplifier
- Oil resistant connecting cable
- High resolution
- Scratch-resistant optics cover made of glass
- Sturdy metal housing



Design

Product name:

SLB-01-500 (transmitter SLB-01-T, receiver SLB-01-R, cable l=500 mm)

SLB-01-1000 (transmitter SLB-01-T, receiver SLB-01-R, cable l=1000 mm)

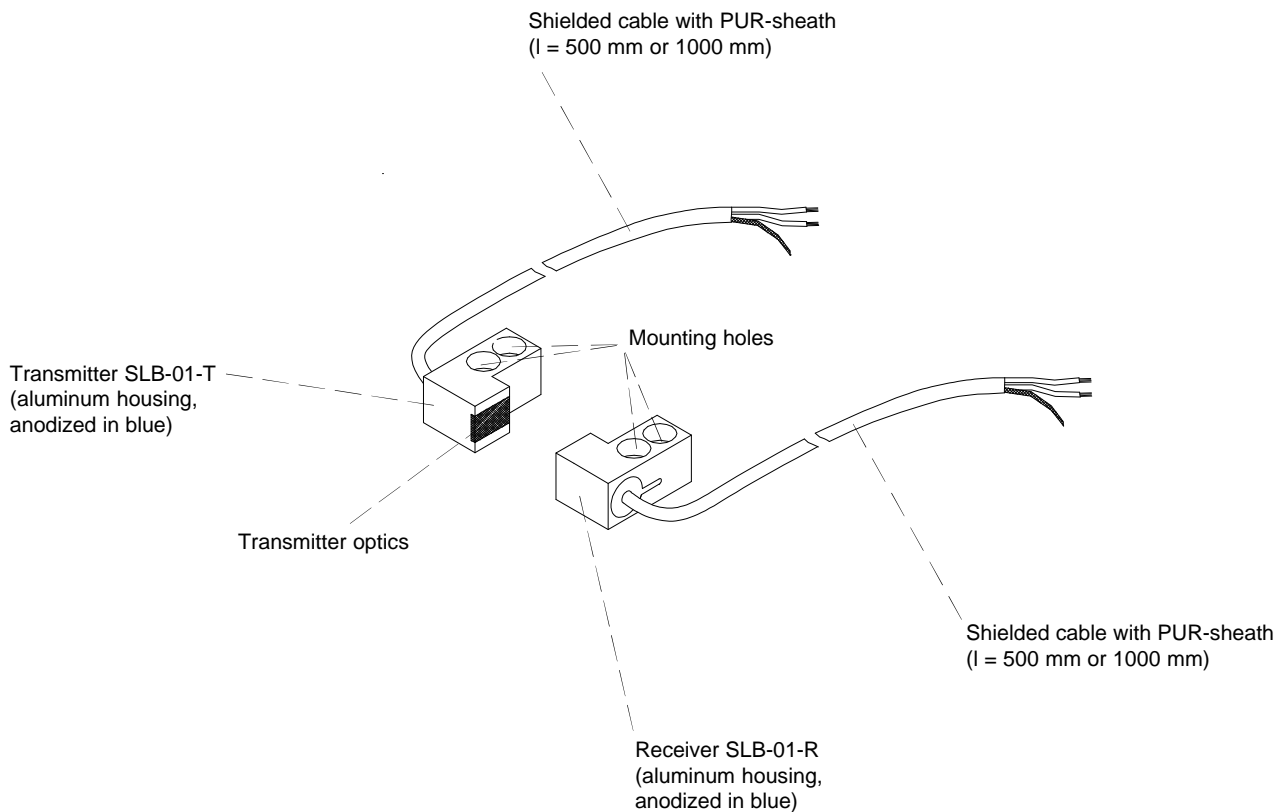



Technical Data

Model	SLB-01
Transmitter	IR-LED, 905 nm, DC operation: max. opt. power < 0,4 mW, AC operation: medium opt. power < 0,4 mW
Minimum detectable object	typ. 50 µm (DC operation) typ. 300 µm (AC operation)
Light spot dimension (at transmitter output)	typ. 2 mm x 1 mm
Repeatability	typ. 10 µm (DC operation) typ. 100 µm (AC operation)
Maximum range	typ. 30 mm (DC operation) typ. 100 mm (AC operation)
Optics	collimated, beam divergency typ. 100 mrad
Optical filter	Daylight rejection filter RG715
Ambient light	up to 5000 Lux (AC operation)
Cable type	PUR sheath, black, shielded
Cable length	500 mm or 1000 mm
Mechanical protection	IP67
Connector type	open wires
Operating temperature range	-20°C ... +80°C
Storage temperature range	-20°C ... +85°C
Housing	Aluminum, anodized in blue
Housing dimensions	approx. length 9 mm x width 8 mm x height 14 mm (see page 3)
EMC test acc. to	IEC - 801...

Dimensions

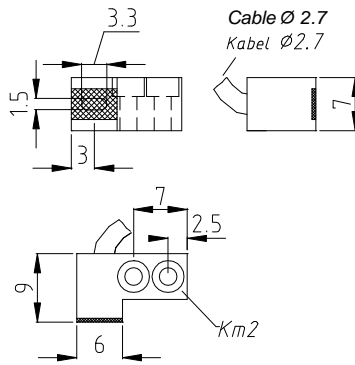
**SLB-01-T (transmitter) and
SLB-01-R (receiver)**



(All dimensions in mm)

Connector Assignment

Pin assignment SLB-01-T (transmitter)

Color:	Assignment:
Brown	Anode
White	Cathode
Shield	

Pin assignment SLB-01-R (receiver)

Color:	Assignment:
Brown	Collector
White	Emitter
Shield	

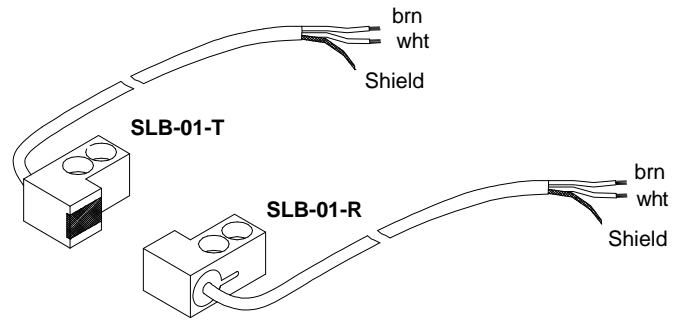

Product Line

Fork light barriers:

FKB-06-...
FKB-06-...-P
FKB-06-...-TPN
FKB-06-...-TPO

FKB-06-...-BL
FKB-06-...-BL-P
FKB-06-...-BL-TPN
FKB-06-...-BL-TPO

FKB-08-...
FKB-08-...-P
FKB-08-...-TPN
FKB-08-...-TPO

FKB-08-...-BL
FKB-08-...-BL-P
FKB-08-...-BL-TPN
FKB-08-...-BL-TPO

Split light barriers:

SLB-01
SLB-01-P
SLB-01-TP

SLB-02
SLB-02-P
SLB-02-TP

SLB-03
SLB-03-P
SLB-03-TP

SLB-04
SLB-04-P
SLB-04-TPN
SLB-04-TPO

SLB-05
SLB-05-P
SLB-05-TPN
SLB-05-TPO

SLB-06
SLB-06-P
SLB-06-TP

SLB-08
SLB-08-P
SLB-08-TP

Amplifiers in tool plug housing:

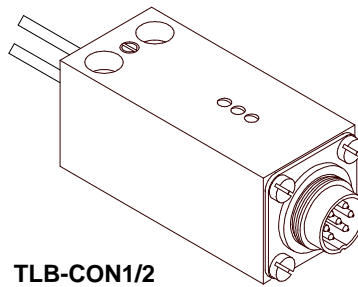

TLB-CON1/2

Connecting cable:
cab-las-agl7 (2m)

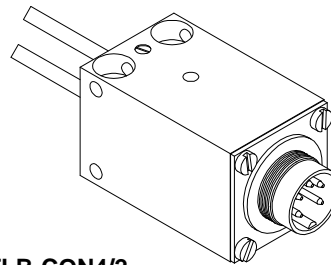

TLB-CON4/2

Connecting cable:
cab-agl5 (2m)