

SPECTRO Series

▶ SPECTRO-1-SLU-UV-SA + SI-SLU-UV-16

- Suitable inter alia for opacity measurement acc. to the 0° method as well as to the 90° method
- High dynamic range
- External transmitter unit with 16 UV-LED, 375 nm (AC-/DC-operation or OFF for luminous objects can be switched)
- High scan frequency
- Gray scale detection (12-bit resolution)
- Insensitive to outside light (in AC-operation)
- Brightness correction can be activated (STAT/DYN)
- Averaging can be activated (from 1 up to over 32000 values)
- TEACH via PC or PLC
- 2 digital inputs (0V/+Ub)
- 2 digital outputs (max. 60 kHz switching frequency)
- 1 analog output (0V...+10V or 4...20mA), selectable via software
- RS232 interface (USB or ETHERNET converter available)
- Parameterizable via Windows® software, scope function
- Temperature compensated (from 0°C to 60°C)
- Automatic threshold correction can be activated
- Switching threshold can be parameterized relative or absolute
- Various switching threshold functions (window, upper/lower threshold)
- Intensity control of luminous objects (LEDs, halogen lamps, displays, ...)

In Proud Partnership with Sensor Instruments

PAQUIN
SENSORS

For technical support, sales, & distribution
within the USA & Canada

www.paquin.com | (800) 831-8217 | paquinsensors@paquin.com



Design

Product name:

SPECTRO-1-SLU-UV-SA (electronic control unit/receiver)

(incl. Windows® PC software SPECTRO1-Scope)

SI-SLU-UV-16 (side light unit/transmitter)

(please order separately)

Accessories: (p. 10-15)

MOUNT-SLU-10°/10°-210

MOUNT-SLU-20°/20°-100

MOUNT-SLU-45°/45°-55

MOUNT-SLU-60°/60°-55

MOUNT-SLU-80/200

MOUNT-SLU-80/500

Mounting angles for reflected light or transmitted light operation

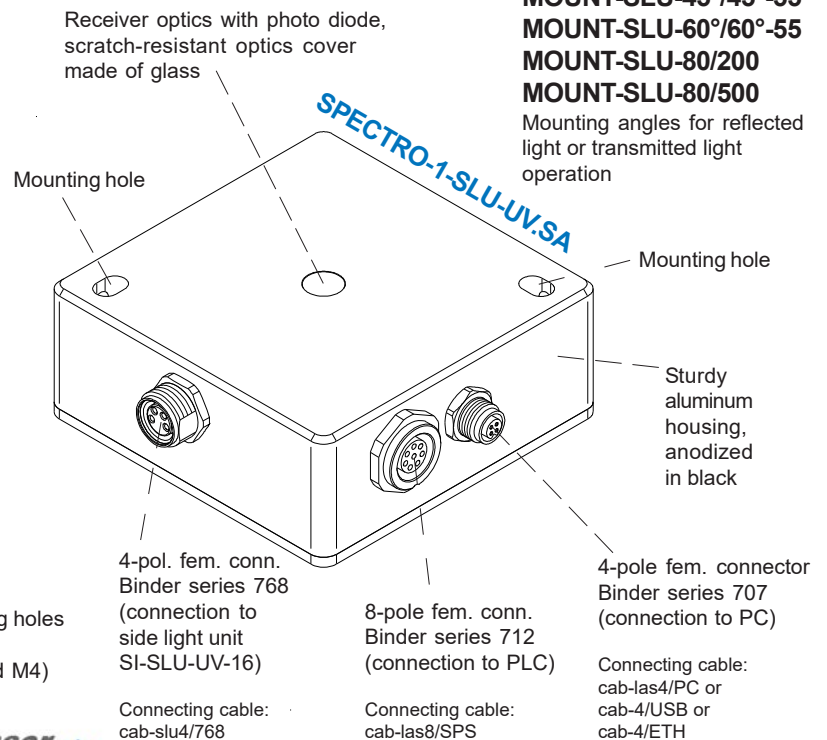
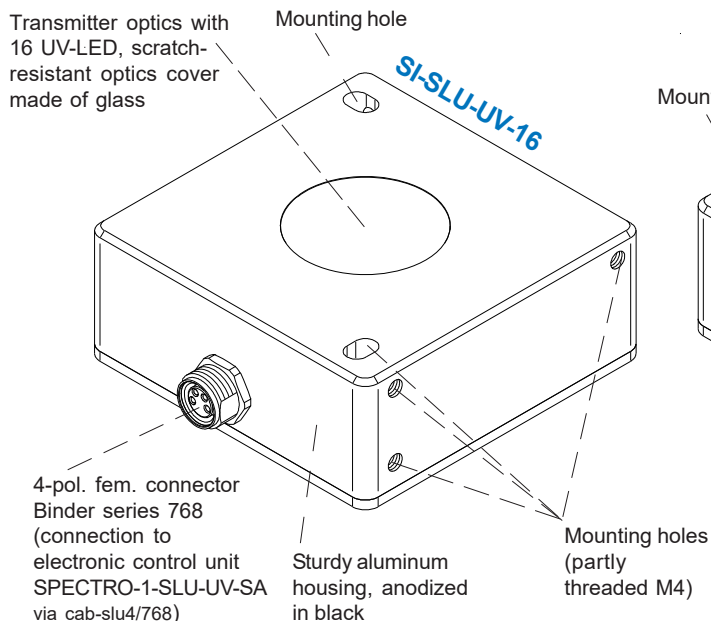



Technical Data

Model	SPECTRO-1-SLU-UV-SA + SI-SLU-UV-16		
Voltage supply	+24VDC (± 10%), reverse polarity protected, overcurrent protected		
Current consumption	< 300 mA		
Max. switching current	100 mA, short circuit proof		
Digital inputs (2x)	IN0 and IN1 (Pin 3 and 4): digital (0V/+24V)		
Digital outputs (2x)	OUT0 and OUT1 (Pin 5 and 6): digital (0V/+24V), npn/pnp-able (bright-/dark-switching, can be switched)		
Analog output (1x)	ANALOG (Pin 8): voltage 0 ... +10V or current 4 ... 20mA, adjustable via PC software		
Interface	RS232		
Pulse lengthening	0 ... 100 ms, adjustable via PC software		
Averaging	max. 32768 values, adjustable via PC software		
Scan frequency (LED mode AC, DC or OFF, can be switched via PC software)	LED mode AC (depends on parameterization):		LED mode DC / OFF (depends on parameterization):
	Frequency [Hz]	Digital outputs	Analog output
	Max. 50 000	Off	Off
	Max. 48 000	On	Off
	Max. 42 000	Off	On
	Max. 41 000	On	On
	Measurements were made with the smallest gain at the receiver (AMP1). At the highest gain (AMP8), the frequency is reduced by a factor of 10.		The frequency is independent of the gain set at the receiver.
Switching frequency	max. 60 kHz		
Analog band width	max. 90 kHz (-3 dB)		
Transmitter optics (light source)	16x UV-LED (375 nm)		
Transmitter control	can be switched via PC software: AC operation (LED MODE-AC), DC operation (LED MODE-DC), OFF operation (LED MODE-OFF)		
Receiver optics	photo diode, UV absorption glass		
Receiver gain setting	8 steps (AMP1 ... AMP8), adjustable via PC software		
Ambient light	max. 5000 Lux		
Reproducibility	2 digits at 12-bit A/D conversion		
Housing dimensions	electronic control unit: LxWxH approx. 65 mm x 65 mm x 26 mm (without flange connectors) side light unit: LxWxH approx. 65 mm x 65 mm x 26 mm (without flange connectors)		
Housing material	aluminum, anodized in black		
Enclosure rating	electronic control unit: IP67 (optics), IP64 (electronics) side light unit: IP64		
Connecting cables	SPECTRO-1-SLU-UV-SA to PLC: cab-las8/SPS or cab-las8/SPS-w or SPECTRO-1-SLU-UV-SA to PC/RS232-interface: cab-las4/PC or cab-las4/PC-w or SPECTRO-1-SLU-UV-SA to PC/USB-interface: cab-4/USB or cab-4/USB-w SPECTRO-1-SLU-UV-SA to PC/Ethernet-interface: cab-4/ETH SPECTRO-1-SLU-UV-SA to side light unit SI-SLU-UV-16: cab-slu4/768		
Type of connector	connection SPECTRO-1-SLU-UV-SA to PLC: 8-pol. fem. connector Binder series 712) connection SPECTRO-1-SLU-UV-SA to PC: 4-pol. fam. connector (Binder series 707) connection SPECTRO-1-SLU-UV-SA to SI-SLU-UV-16: 4-pol. M8 fem. connector (Binder series 768)		
Operating temp. range	-20°C ... +55°C		
Storage temperature range	-20°C ... +85°C		
EMC test acc. to	DIN EN 60947-5-2		



Dimensions

SPECTRO-1-SLU-UV-SA

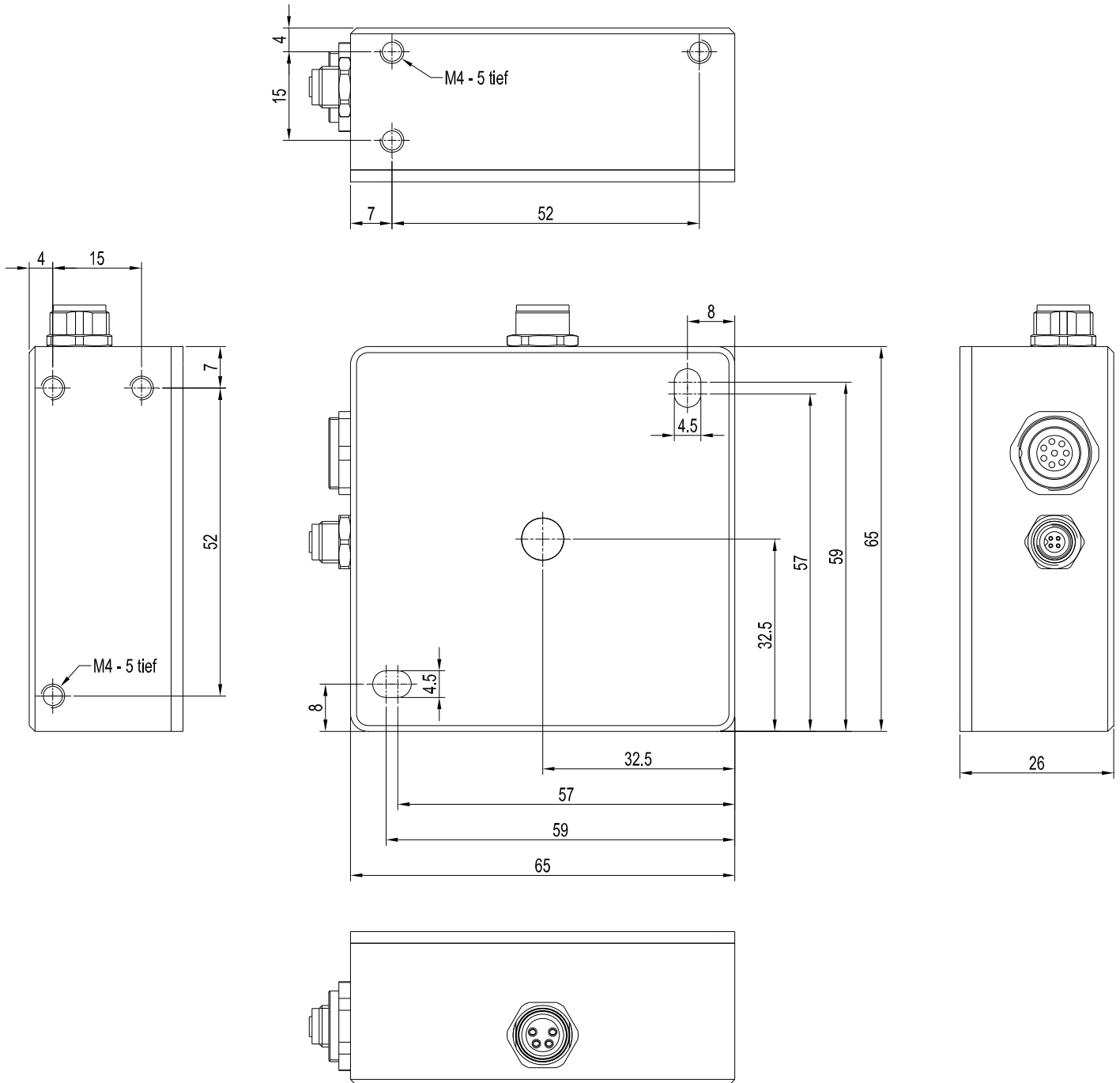

All dimensions in mm

Dimensions

SI-SLU-UV-16

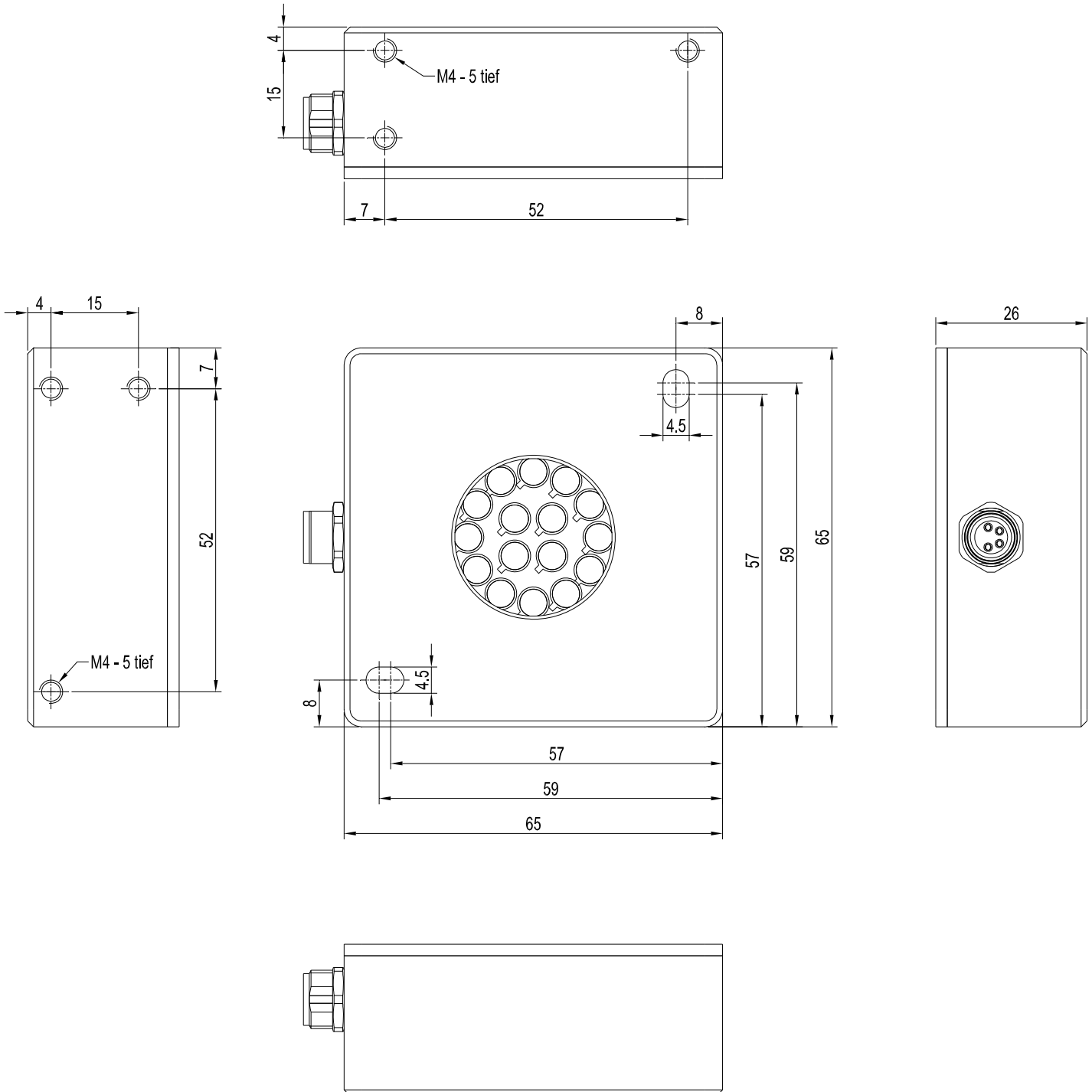

All dimensions in mm



Connector Assignment

Connection to PLC:

8-pole fem. connector Binder series 712

Pin:	Color:	Assignment:
1	white	GND (0V)
2	brown	+24VDC ($\pm 10\%$)
3	green	IN0 (Digital 0: 0 ... 1V, Digital 1: +Ub - 10%)
4	yellow	IN1 (Digital 0: 0 ... 1V, Digital 1: +Ub - 10%)
5	grey	OUT0 (Digital 0: Type 0 ... 1V, Digital 1: Type +Ub - 10%)
6	pink	OUT1 (Digital 0: Type 0 ... 1V, Digital 1: Type +Ub - 10%)
7	blue	not connected
8	red	ANALOG (voltage 0...+10V or current 4...20mA)

Connecting cable:
 cab-las8/SPS-(length)
 cab-las8/SPS-w-(length)
 (standard length 2m)

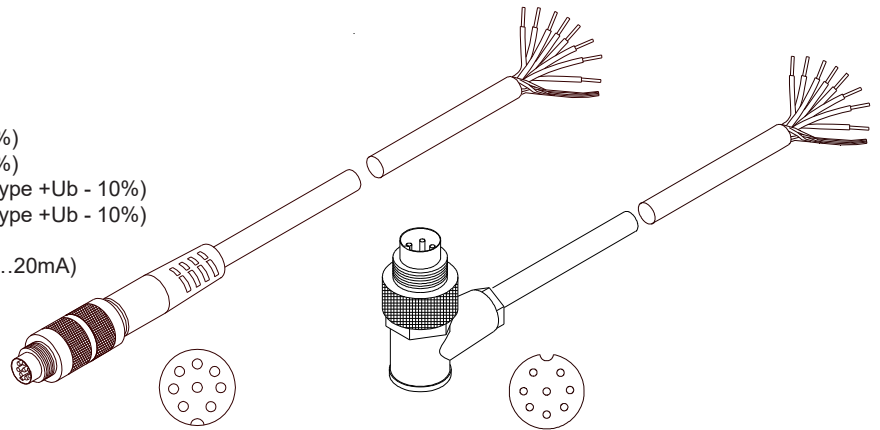

cab-las8/SPS-...
 (max. length 25m, outer jacket: PUR)

cab-las8/SPS-w-...
 (max. length 25m, outer jacket: PUR)

Connection to PC:

4-pole fem. connector Binder Series 707

Pin:	Assignment:
1	+24VDC (+Ub, OUT)
2	GND (0V)
3	RxD
4	TxD

Connection via RS232 interface at the PC:

Connecting cable:
 cab-las4/PC-(length)
 cab-las4/PC-w-(length) (angle type 90°)
 (standard length 2m)

alternative:

Connection via USB interface at the PC:

USB converter (incl. driver software):
 cab-4/USB-(length)
 cab-4/USB-w-(length) (angle type 90°)
 (standard length 2m)

alternative:

Connection to local network via Ethernet bus:

Ethernet converter (incl. software „SensorFinder“):
 cab-4/ETH-500
 (standard length 0.5m)

Optional: External CAT5 cable, e.g.

cab-eth/M12D-RJ45-flx-(length)

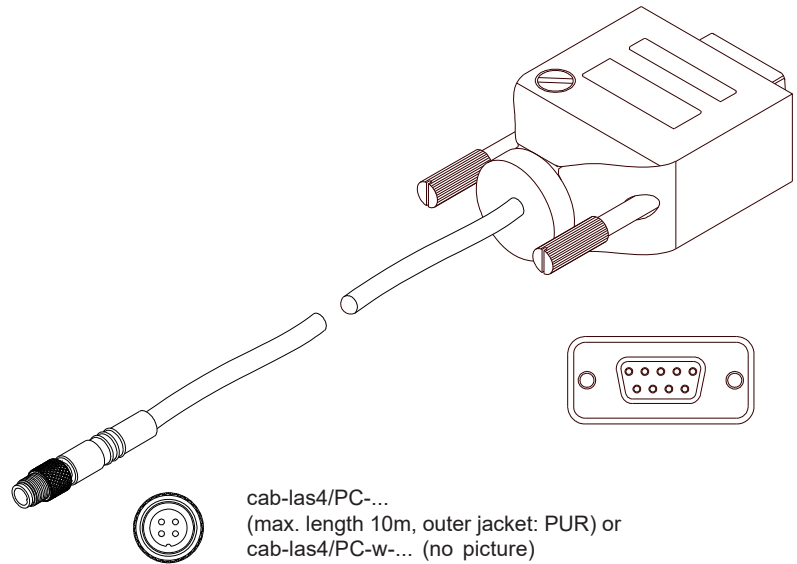

cab-las4/PC-...
 (max. length 10m, outer jacket: PUR) or
 cab-las4/PC-w-... (no picture)
 (max. length 5m, outer jacket: PUR)

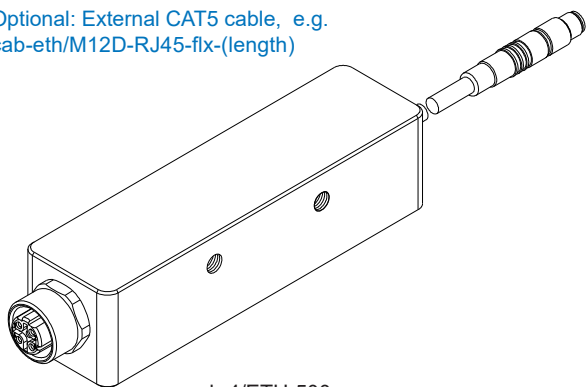

cab-4/ETH-500
 (length 0.5m, outer jacket: PUR)
 4-pole M12 fem. conn. (D-coded)
 for connection of an external
 CAT5 cable, e.g.
 cab-eth/M12D-RJ45-flx-(length)

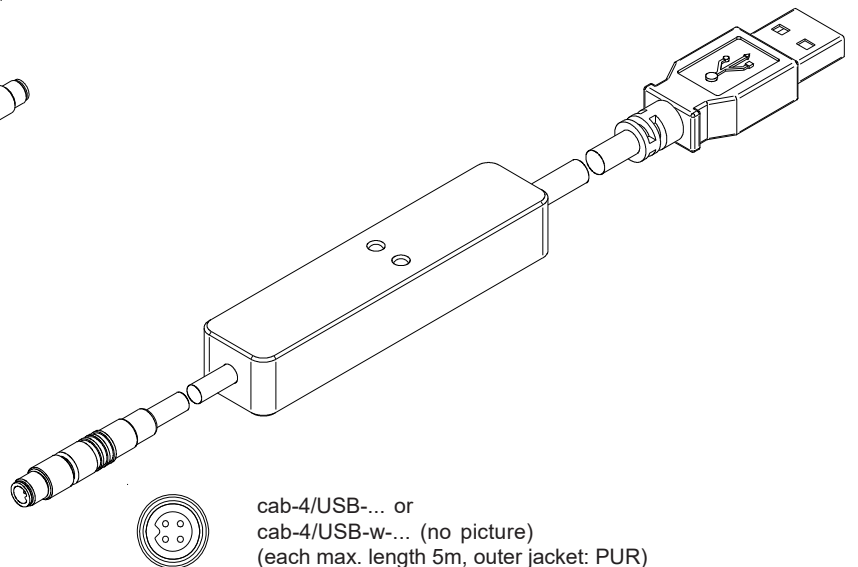

cab-4/USB-... or
 cab-4/USB-w-... (no picture)
 (each max. length 5m, outer jacket: PUR)



Connecting Cable
Connection
SPECTRO-1-SLU-UV-SA to SI-SLU-UV-16:

Connecting cable:
 cab-slu4/768-2m
 (standard length 2m)

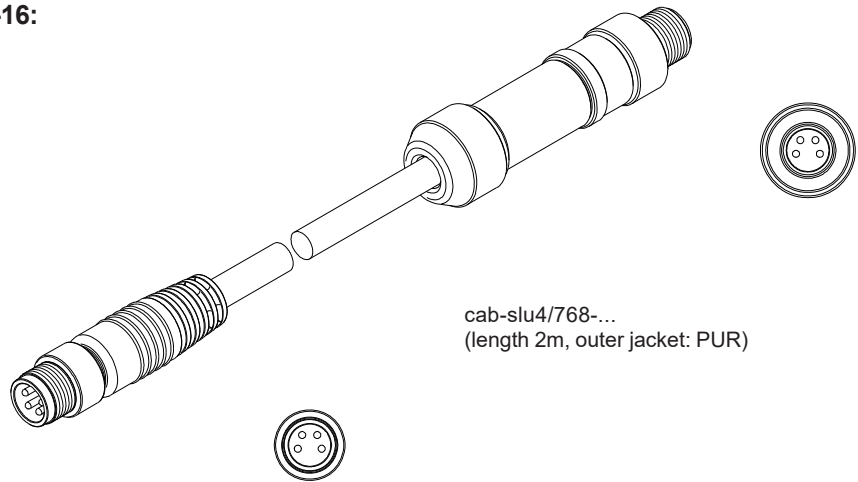

cab-slu4/768-...
 (length 2m, outer jacket: PUR)



Measuring Principle
Measuring principle of the sensors of SPECTRO-1 series:

The sensors of the SPECTRO-1 series are of single-channel design, i.e. they acquire the analog signal that comes from a receiver and evaluate this signal. Various light sources such as white light, UV light, IR light, or a laser can be used as a transmitter. The receiver is correspondingly matched to the transmitter. The acquired analog signal is provided through a voltage output and a current output.

The software can be used to select various evaluation modes for the analog signal. The status of the analog signal is provided through 2 digital outputs in accordance with the selected evaluation mode. A digital input allows external "teaching" of the sensor. An additional input allows the "freezing" of the analog output signal upon a positive input edge.

The SPECTRO-1 sensor allows highly flexible signal acquisition. The sensor, for example, can be operated in alternating-light mode (AC mode), which means the sensor is not influenced by external light, or in constant-light mode (DC mode), which provides outstanding high-speed sensor operation. An OFF function deactivates the sensor's integrated light source and changes to DC mode, which allows the sensor to detect so-called "self-luminous objects". With the stepless adjustment of the integrated light source, the selectable gain of the receiver signal, and an INTEGRAL function the sensor can be adjusted to almost any surface or any "self-luminous object".

A micro-controller performs 12-bit analog/digital conversion of the analog signal, which allows recording and evaluation of the signal. Furthermore the SPECTRO-1 sensor offers various options for intelligent signal processing such as e.g. dirt accumulation compensation.

Parameters and measurement values can be exchanged between PC and sensor either through RS232 or Ethernet (using an Ethernet converter). Through the interface all the parameters can be stored in the non-volatile EEPROM of the sensor.

The PC software facilitates the parameterisation, diagnostics, and adjustment of the sensor system (oscilloscope function). The software furthermore provides a data recorder function that automatically records data and stores them on the hard disk of the PC.

SPECTRO-1 sensors are temperature-compensated over a range of 0°C to 80°C.

Possible firmware updates can be easily performed through the RS232 interface, even with the sensor system in installed condition.

When parameterisation is finished, the color sensor continues to operate with the current parameters in STAND-ALONE mode without a PC.



Parameterization

Windows® user interface:

(The current software version is available for download on our website.)

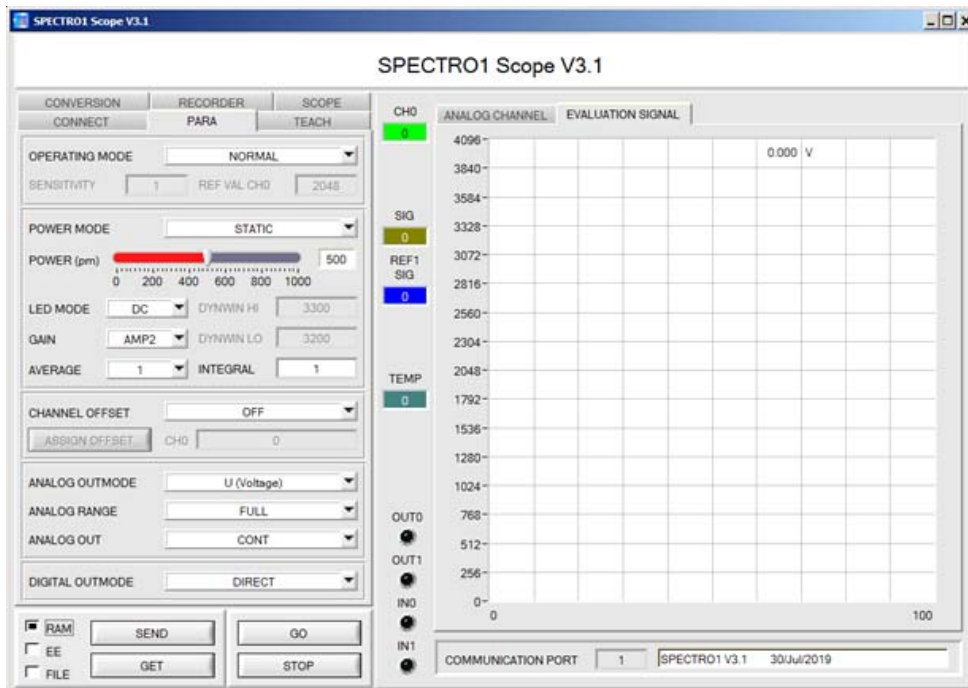

The PC software SPECTRO1-Scope facilitates the parameterization, the diagnosis, and the adjustment of the sensor system (oscilloscope function). Moreover, the software features a data recorder function that allows the automatic recording of recorded data and the saving of those at the hard disk of the PC.

Parameters and measurement values can be exchanged between PC and sensor either through RS232 or Ethernet (using an Ethernet converter). Through the interface all the parameters can be stored in the non-volatile EEPROM of the sensor.

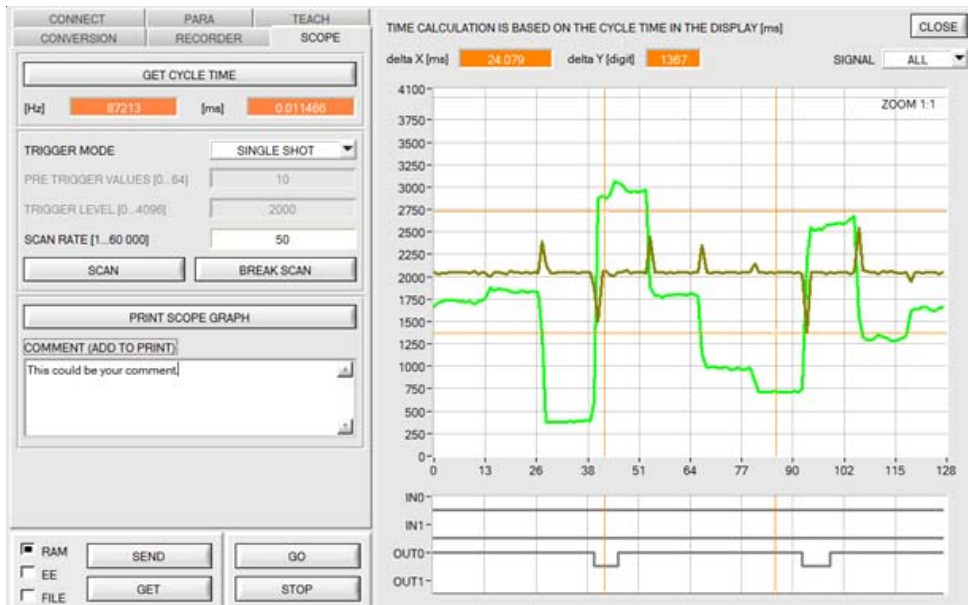

The SCOPE tab visualises an oscilloscope.



Firmware Update

Firmware update by means of the software „FirmwareLoader“:

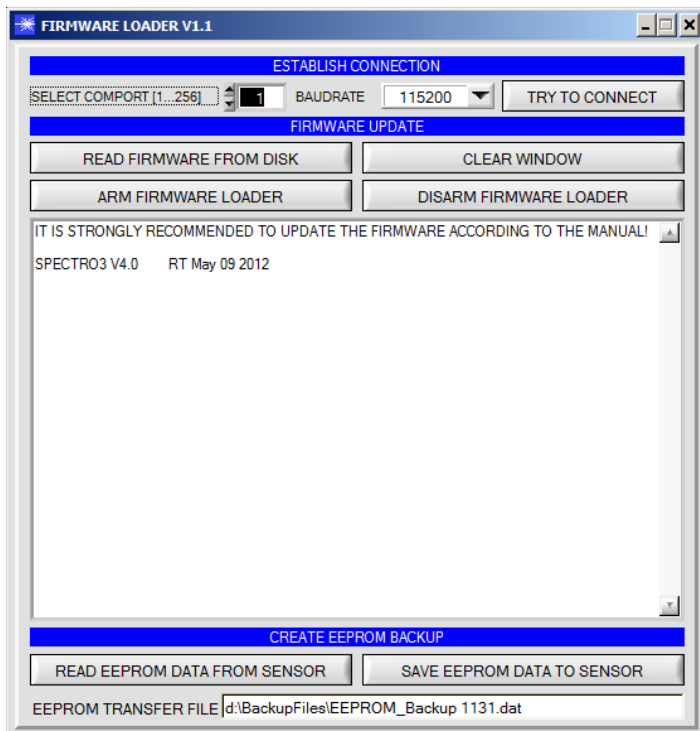

The software „Firmware Loader“ allows the user to perform an automatic firmware update. The update will be carried out through the RS232 interface.

An initialisation file (xxx.ini) and a firmware file (xxx.elf.S) are required for performing a firmware update. These files can be obtained from your supplier. In some cases an additional firmware file for the program memory (xxx.elf.p.S) is also needed, and this file will be automatically provided together with the other two files.



Mounting Accessories

MOUNT-SLU-10°/10°-210

Mounting bracket for fixation of SPECTRO-1-SLU-UV-SA (electronic control unit/receiver) and SI-SLU-UV-16 (side light unit/transmitter)

Enables reflected light operation in an angle of 20° (2x 10°) at a reference distance of 210 mm

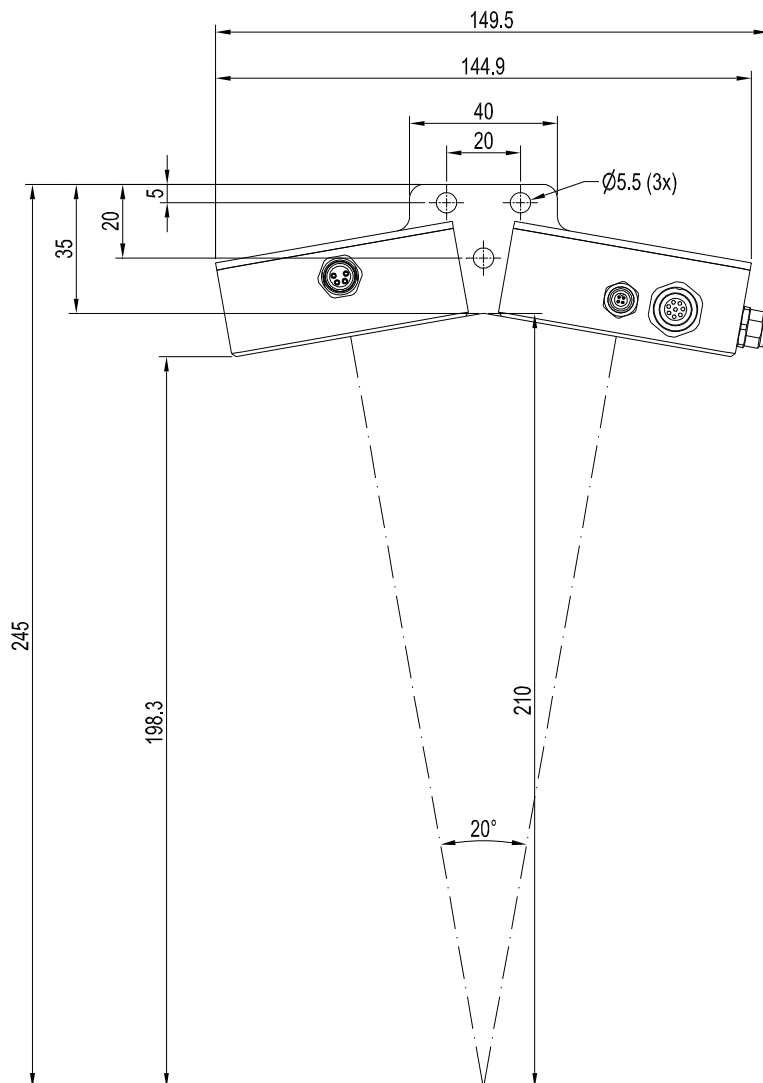
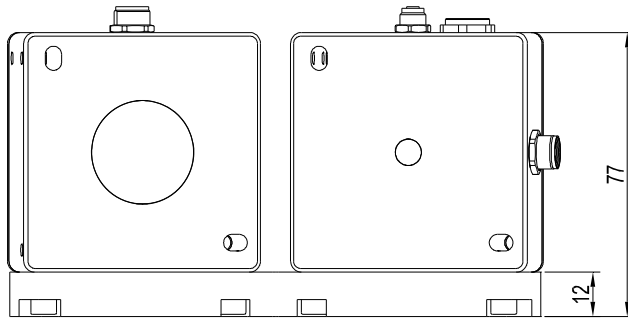
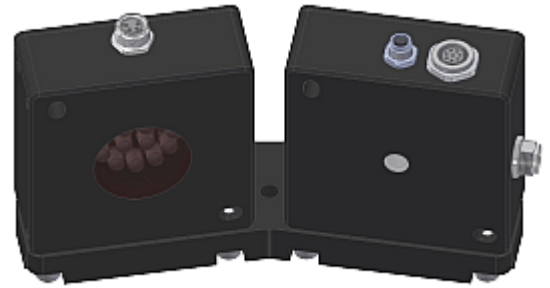

All dimensions in mm



Mounting Accessories

MOUNT-SLU-20°/20°-100

Mounting bracket for fixation of SPECTRO-1-SLU-UV-SA (electronic control unit/receiver) and SI-SLU-UV-16 (side light unit/transmitter)

Enables reflected light operation in an angle of 40° (2x 20°) at a reference distance of 100 mm

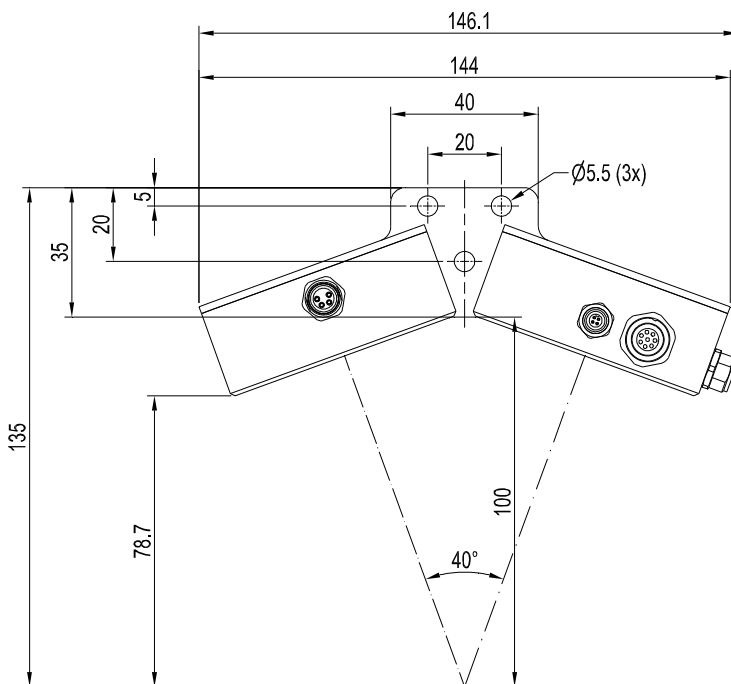
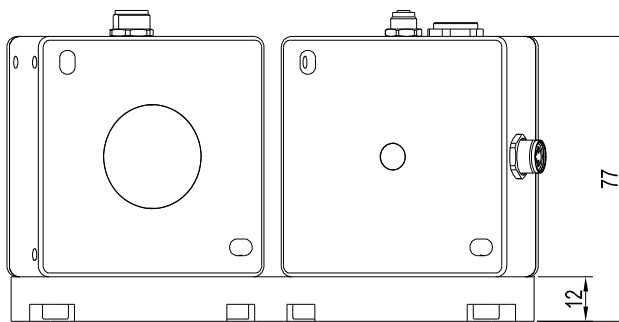

All dimensions in mm



Mounting Accessories

MOUNT-SLU-45°/45°-55

Mounting bracket for fixation of SPECTRO-1-SLU-UV-SA (electronic control unit/receiver) and SI-SLU-UV-16 (side light unit/transmitter)

Enables reflected light operation in an angle of 90° (2x 45°) at a reference distance of 55 mm

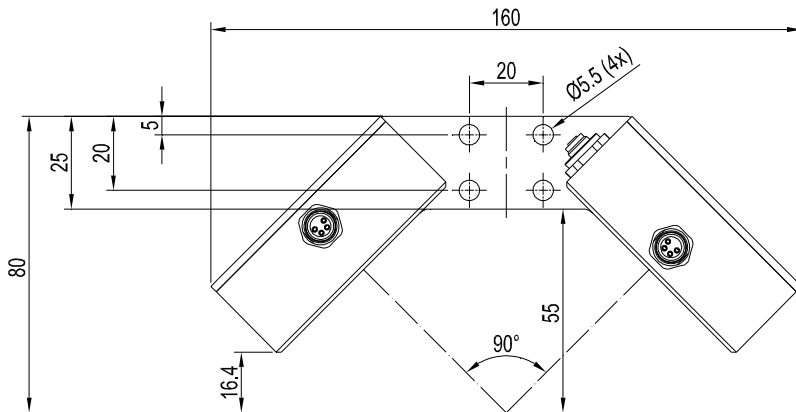
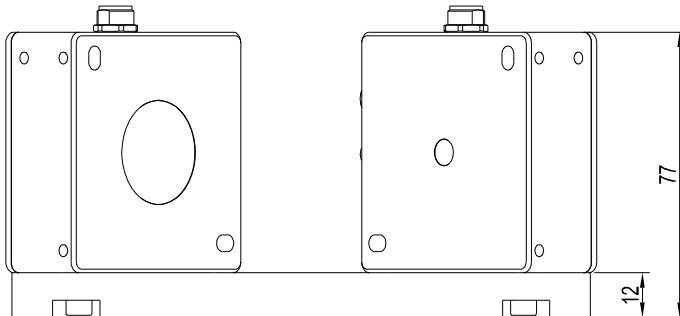
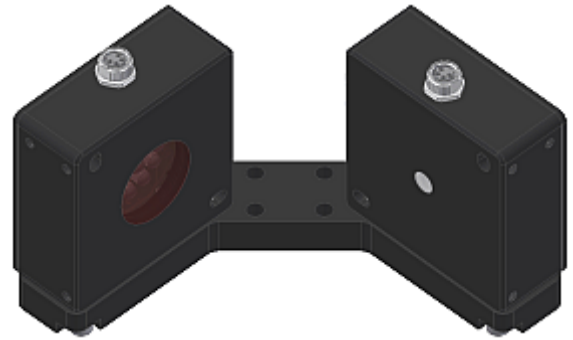

All dimensions in mm



Mounting Accessories

MOUNT-SLU-60°/60°-55

Mounting bracket for fixation of SPECTRO-1-SLU-UV-SA (electronic control unit/receiver) and SI-SLU-UV-16 (side light unit/transmitter)

Enables reflected light operation in an angle of 120° (2x 60°) at a reference distance of 55 mm

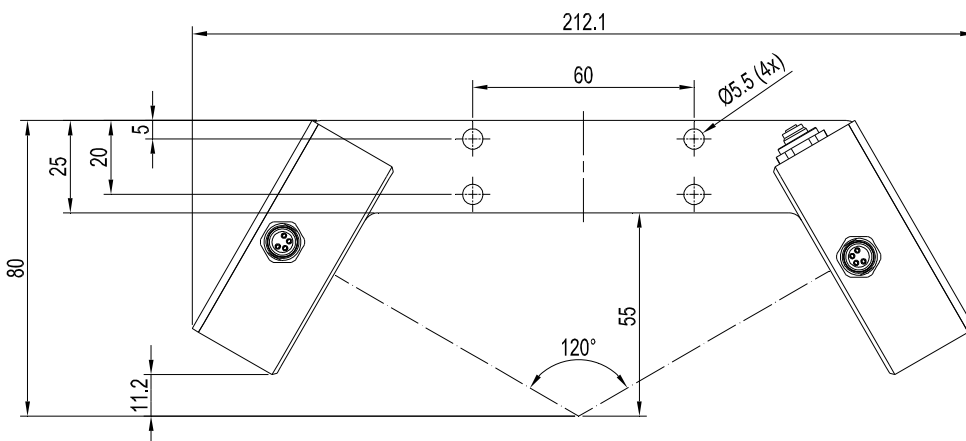
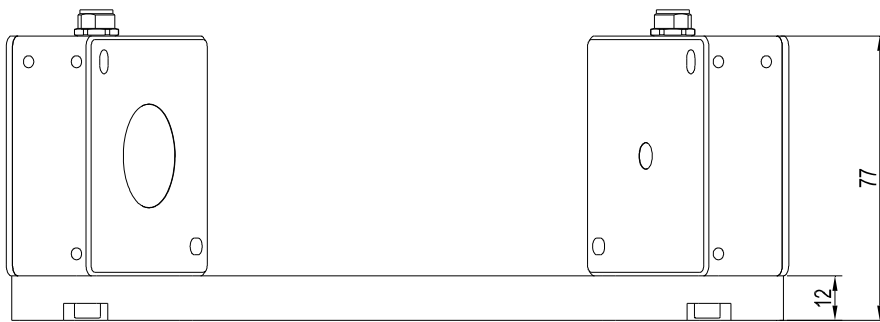

All dimensions in mm



Mounting Accessories

MOUNT-SLU-80/200

Mounting bracket for fixation of SPECTRO-1-SLU-UV-SA (electronic control unit/receiver) and SI-SLU-UV-16 (side light unit/transmitter)

Enables transmitted light operation at a distance of 80 mm with sensor units fixed at the end of the fork legs with an inner length of 200 mm

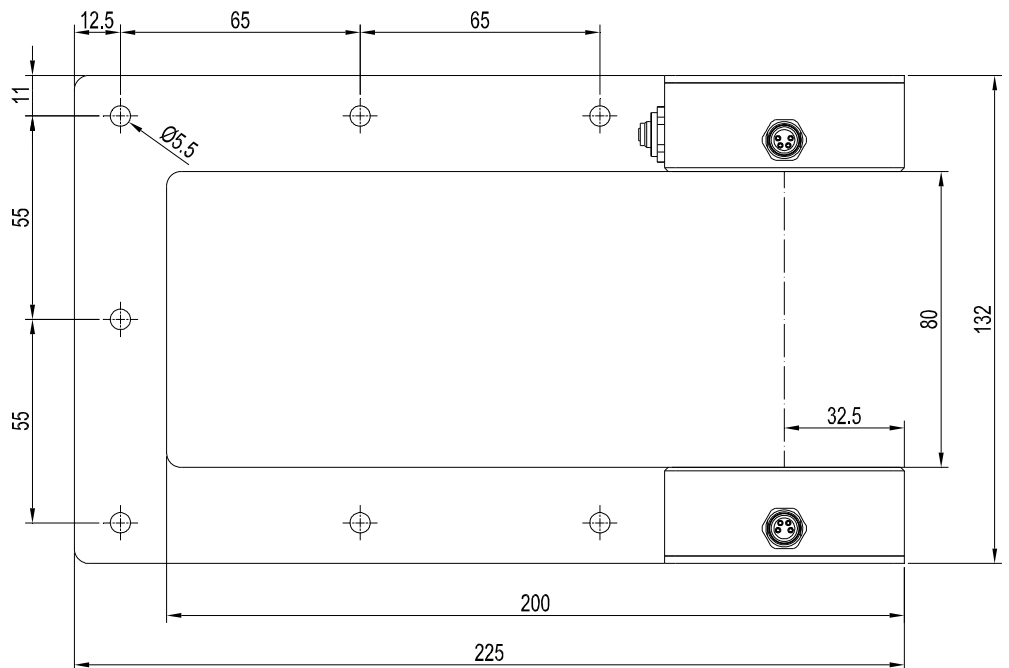
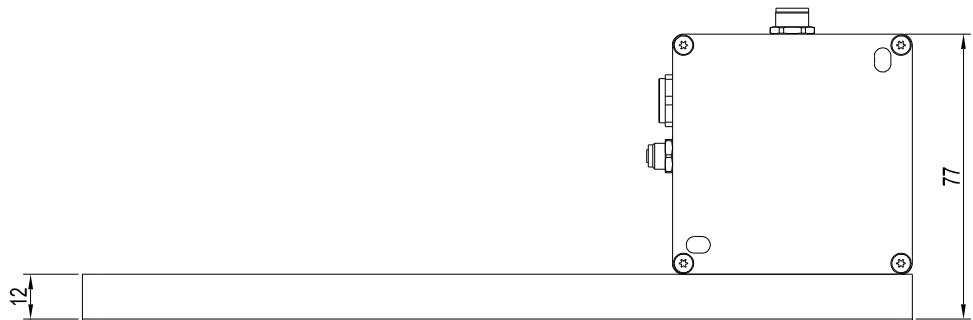
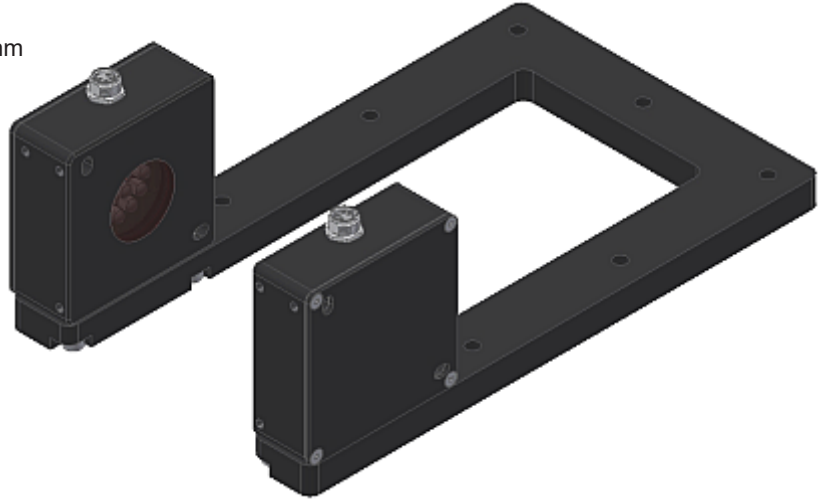

All dimensions in mm



Mounting Accessories

MOUNT-SLU-80/500

Mounting bracket for fixation of SPECTRO-1-SLU-UV-SA (electronic control unit/receiver) and SI-SLU-UV-16 (side light unit/transmitter)

Enables transmitted light operation at a distance of 80 mm with sensor units fixed at the end of the fork legs with an inner length of 500 mm

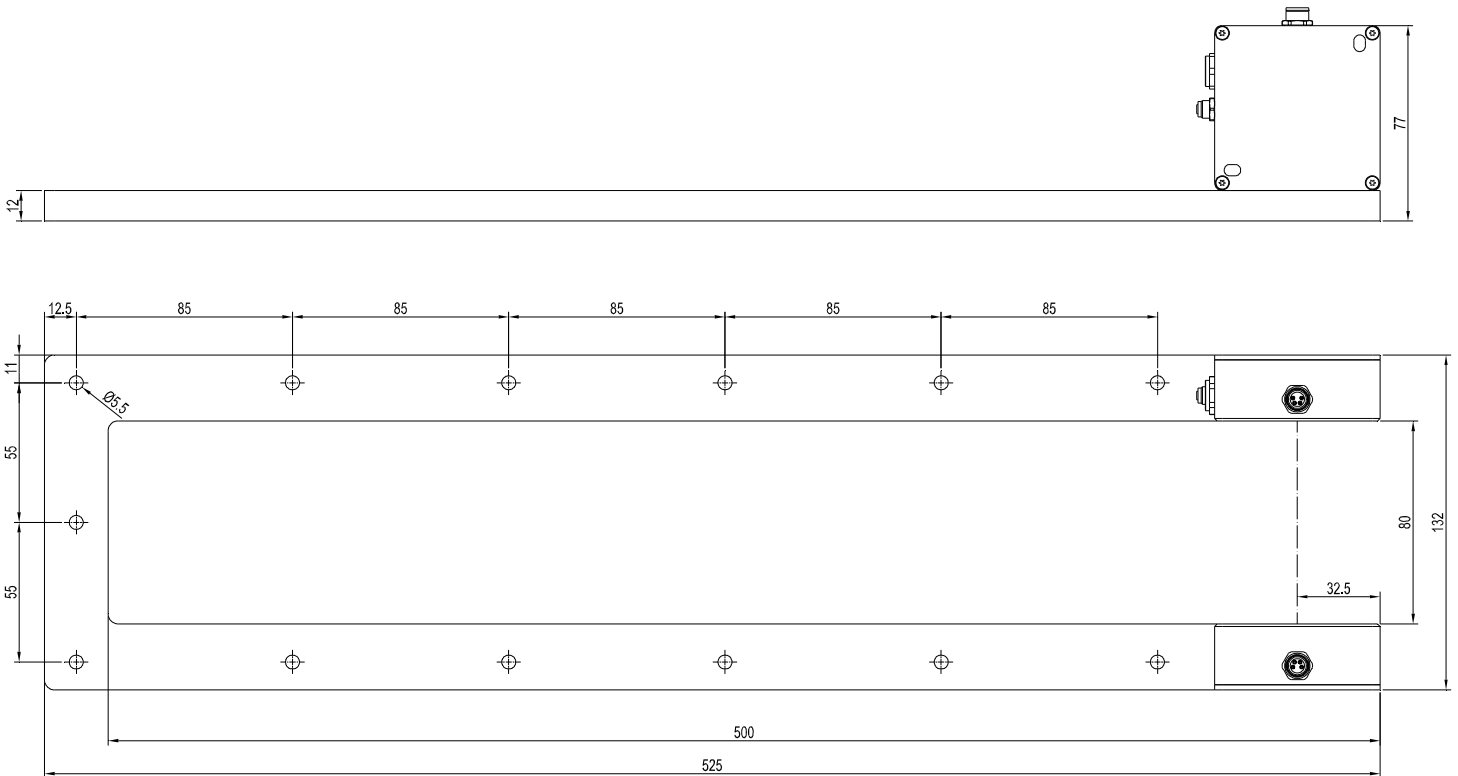
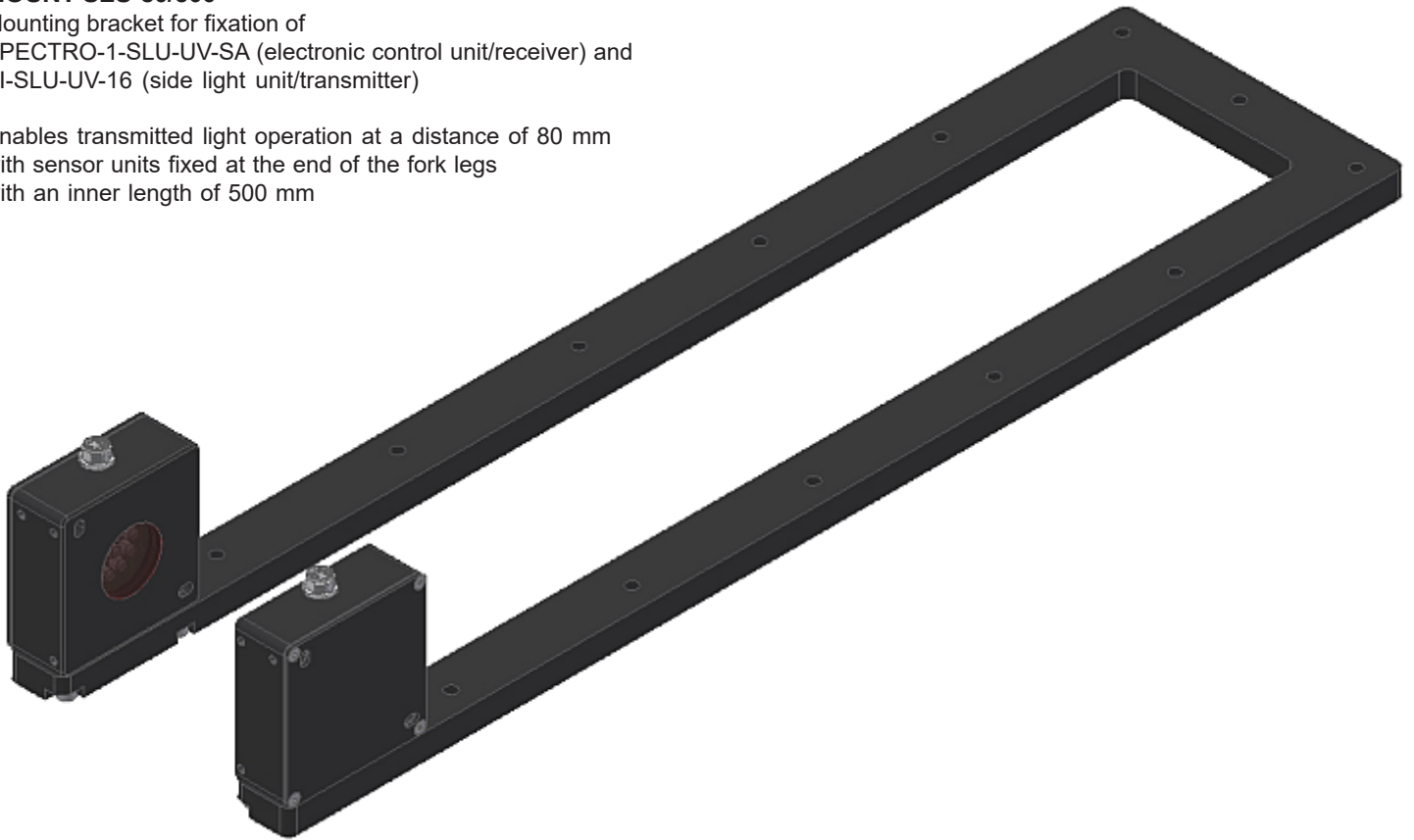

All dimensions in mm

