

SI-JET Series

▶ SI-JET3-CON8 A-LAS-M12-...-C A-LAS-M18-...-C

By way of the analog laser light barriers of type A-LAS-M12 or A-LAS-M18, the SI-JET3-CON8 Spray Jet Monitoring System monitors the density and the symmetry around the opening angle of the spray jet.

With the comprehensive SI-JET-Scope software the system can be parameterised under Windows®.

- Connection of up to three A-LAS laser light barriers
- Various aperture sizes available
- Big transmitter/receiver distance possible (up to 8 m)
- Averaging can be adjusted (over 32000 values)
- 5 switching outputs (up to 31 switching states can be stored)
- RS232 interface and Windows® user interface
- Teachable by means of integrated teach button, PLC, or PC
- Insensitive to outside light
- Blast air top parts for transmitter and receiver optics to prevent dirt accumulation due to spray particles

In Proud Partnership with Sensor Instruments

PAQUIN
SENSORS

For technical support, sales, & distribution
within the USA & Canada

www.paquin.com | (800) 831-8217 | paquinsensors@paquin.com

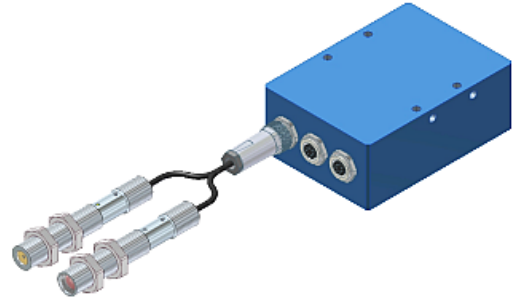

Design

Product name:

SI-JET3-CON8 (Electronic control unit, incl. Windows® PC software SI-JET-Scope)

A-LAS-M12-(aperture)*-C-(cable length)**

(Laser sensor frontend in M12 housing: transmitter + receiver)

A-LAS-M18-(aperture)*-C-(cable length)**

(Laser sensor frontend in M18 housing: transmitter + receiver)

* Various apertures available for A-LAS-M12: cf. page 5

Various apertures available for A-LAS-M18: cf. page 6

** Various cable lengths available: 1m, 2m, 3m, 4m, or 5m

Teach button
(external teaching)

SI-JET3-CON8

(with possibility for
connection of up to
3 frontends of type
A-LAS-M12-...-C)

8-pole fem. connector
Binder 712
(connection to PLC)
Connecting cable:
cab-las8/SPS

Switching state
indication
(5 yellow LEDs)

5-pole fem. connector
Binder 712
(RS232 interface)
Connecting cable:
cab-las5/PC or
cab-las5/USB or
SI-RS232/Ethernet-5

3x potentiometer for
adjustment of the
respective gain of the
3 sensor frontends

Sturdy aluminum housing,
anodized in blue

Mounting
possibilities
(threaded M5)

3x A-LAS sensors:

A-LAS-M12-...-C or

A-LAS-M18-...-C

(Laser through-beam sensor)

Accessories: (cf. p. 12):

ABL-M12-... (Blast air top part)

ABL-M18-... (Blast air top part)

FL-12, WFL-12 (Mounting flanges)

FL-18, WFL-18 (Mounting flanges)

Technical Data

Model	SI-JET3-CON8
Voltage supply	+24VDC (± 10%), reversed-polarity protected, overload protected
Current consumption	typ. 200 mA
Operating temperature	-10°C ... 50°C
Enclosure rating	IP64
Housing material	Aluminum, anodized in blue
Housing dimensions	approx. 90 mm x 65 mm x 35 mm (without connectors)
Type of connector	Connection to PC: 5-pole female connector type Binder 712 Connection to PLC: 8-pole female connector type Binder 712 Connection to frontend A-LAS-M12-...-C: 7-pole fem. connector type Binder 712 Connection to frontend A-LAS-M18-...-C: 7-pole fem. connector type Binder 712
External teaching	by means of an integrated push-button
Switching state indication	by means of 5 yellow LEDs
Interface	RS232, parameterizable under Windows®
Averaging	adjustable under Windows: max. 32768 values
Outputs	OUT0 ... OUT4, digital (0V/+U _B), short-circuit-proof, 100 mA max. switching current; npn- or pnp-capable (bright- and dark-switching can be adjusted)
External teach input IN0	+U _B -Signal (min. pulse length 250 ms, max. pulse length 1000 ms)
Pulse lengthening	adjustable under Windows®: 0 ms .. 100 ms
EMV test acc. to	DIN EN 60947-5-2 

System Design

Electronic control unit and A-LAS sensor frontend

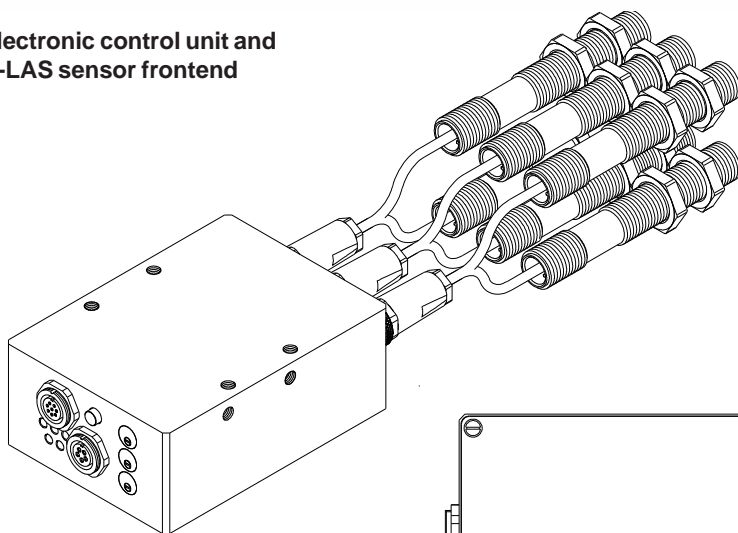

SI-JET3-CON8
(with possibility for connection of up to 3 frontends A-LAS-M12-...-C or A-LAS-M18-...-C)

A-LAS-M12-...-C or A-LAS-M18-...-C

(transmitter and receiver frontend incl. cable with 7-pole connector Binder 712, cable length l = 1m, 2m, 3m, 4m, or 5m)

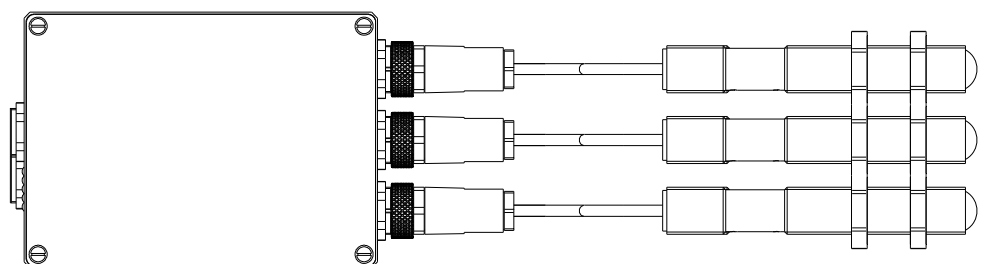

Electronic control unit

A-LAS sensors (transmitter + receiver)



Technical Data

Model	A-LAS-M12-...-C	A-LAS-M18-...-C
Shape	laser light barrier in M12 shape.	laser light barrier in M18 shape.
Laser	semi-conductor laser, 670 nm, modulated, 30 kHz, 1 mW max. opt. power, laser class 2 acc. to DIN EN 60825-1.	
Available aperture sizes	round apertures: from Ø 0.15 mm to Ø 2 mm rectangular apertures: from 0.2 mm x 0.5 mm to 4 mm x 1 mm	round apertures: from Ø 0.15 mm to Ø 3 mm rectangular apertures: from 0.2 mm x 0.5 mm to 16 mm x 1 mm
Working range	max. 8 m (depends on aperture used)	max. 10 m (depends on aperture used)
Resolution	0.025%	
Reproducibility	typ. 0.1% of aperture size	
Optical filter	red light filter RG 630 and interference filter	
Voltage supply	transmitter: +5VDC, receiver: +5VDC...+12VDC	
Current consumption	transmitter: typ. 50 mA, receiver: typ. 20 mA	
Ambient light (extraneous light)	at 5000 Lux extraneous light in in receiver optics ambience: typ. < 300 mV influence on analog signal	
Operating temperature range	0°C ... +50°C	
Storage temperature range	-20°C ... +85°C	
Type of connector	7-pole circular connector, type Binder series 712	
Housing material	brass, nickel-plated	
Housing dimensions	length approx. 75 mm, thread M12	length approx. 90.5 mm, thread M18
Enclosure rating	IP67	
EMC test acc. to	DIN EN 60947-5-2 	
Cable length	1m, 2m, 3m, 4m, or 5m	



Laser Warning

The transmitters of the laser one-way light barriers of series A-LAS comply with laser class 2 according to EN 60825-1. The use of these laser transmitters therefore requires no additional protective measures.

The transmitters of the series A-LAS are supplied with a laser warning label.



LASER RADIATION
DO NOT STARE INTO THE BEAM
CLASS II LASER PRODUCT

Dimensions

SI-JET3-CON8
(Electronic control unit)

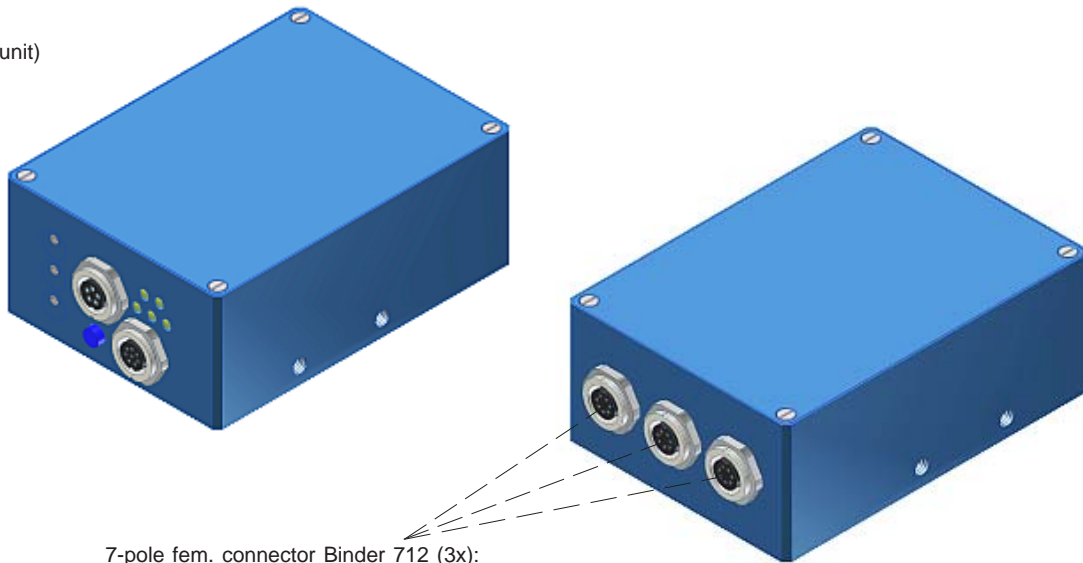

7-pole fem. connector Binder 712 (3x):
Connection of up to 3 sensor frontends
type A-LAS-M12-...-C or A-LAS-M18-...-C

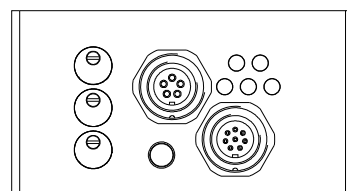
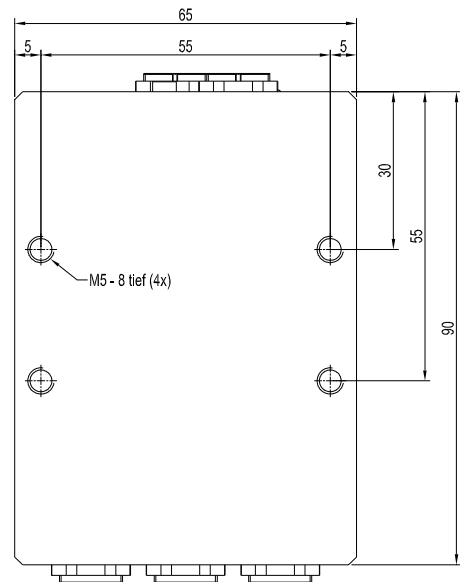
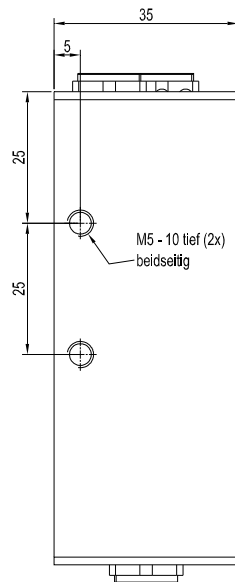
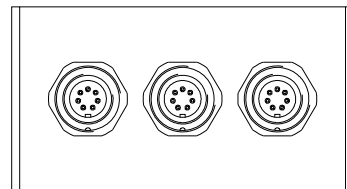

All dimensions in mm



Dimensions

A-LAS-M12-(aperture)-C-(cable length)

(Sensor frontend: transmitter + receiver)

Available aperture sizes:

(same aperture for transmitter and receiver frontend)

Round aperture *d*... (mm):

- d0.15
- d0.3
- d0.5
- d0.7
- d1.0
- d2.0
- d3.0

Rectangular aperture *AxB* (mm):

- 0.2 x 0.5 = 0.5 x 0.2
- 0.2 x 1.0 = 1.0 x 0.2
- 0.3 x 0.5 = 0.5 x 0.3
- 0.3 x 1.0 = 1.0 x 0.3
- 0.3 x 1.5 = 1.5 x 0.3
- 0.3 x 3.0 = 3.0 x 0.3
- 0.5 x 1.0 = 1.0 x 0.5
- 0.5 x 2.0 = 2.0 x 0.5
- 0.5 x 3.0 = 3.0 x 0.5
- 0.5 x 4.0 = 4.0 x 0.5
- 0.75 x 2.0 = 2.0 x 0.75
- 0.75 x 3.0 = 3.0 x 0.75
- 1.0 x 1.0
- 1.0 x 2.0 = 2.0 x 1.0
- 1.0 x 4.0 = 4.0 x 1.0
- 2.0 x 1.2 = 1.2 x 2.0
- 2.0 x 3.0 = 3.0 x 2.0

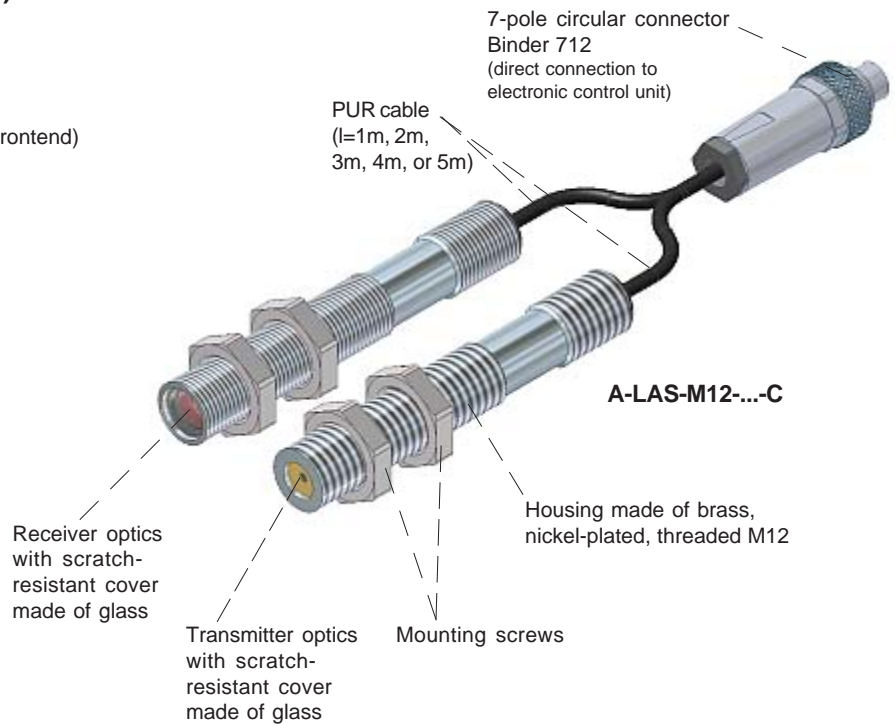

Available cable lengths:

(same cable length for transmitter and receiver frontend)

1m, 2m, 3m, 4m, or 5m

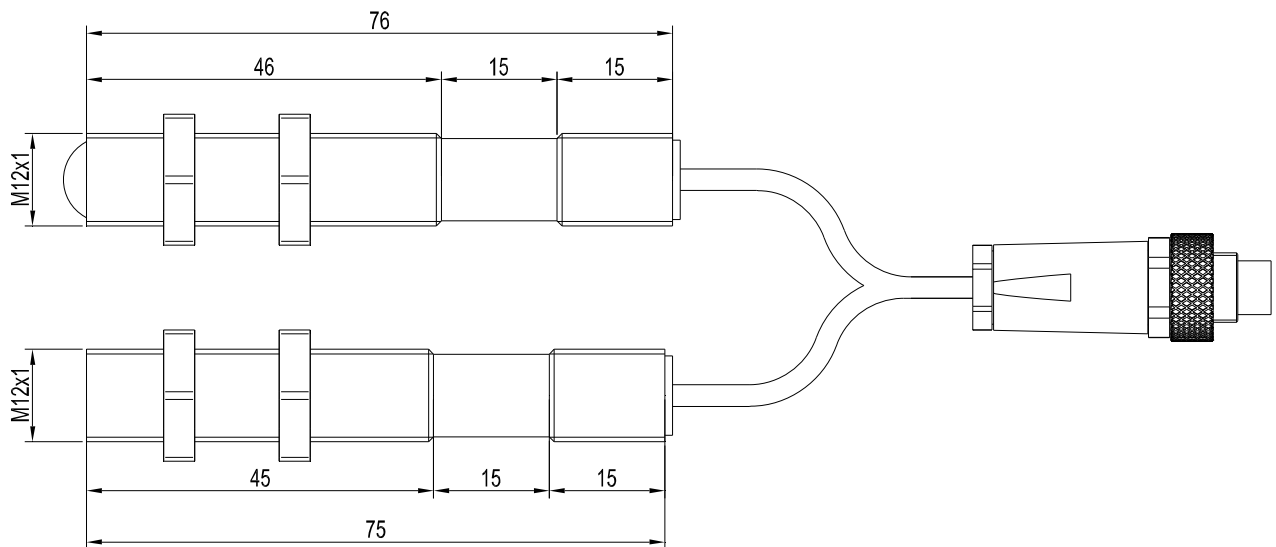

Alle Abmessungen in mm



Dimensions

A-LAS-M18-(aperture)-C-(cable length)
A-LAS-M18-M*-(aperture)-C-(cable length)

Available aperture sizes:

(same aperture for transmitter and receiver frontend)

Round aperture d... (mm):

- d0.15
- d0.3
- d0.5
- d0.7
- d1.0
- d2.0
- d3.0

Rectangular aperture AxB (mm):

- 3x1 = 1x3
- 0.3x1.5 = 1.5x0.3
- 0.3x3 = 3x0.3
- 0.5x1 = 1x0.5
- 0.5x4 = 4x0.5
- 0.5x6.5 = 6.5x0.5
- 0.75x2 = 2x0.75
- 0.75x3 = 3x0.75
- 1x2 = 2x1
- 1x4 = 4x1
- 2x1.2 = 1.2x2
- 2x3 = 3x2
- 7x3 = 3x7 (=without aperture)

... for type A-LAS-M18-M-...:

- 9.5x1.5 = 1.5x9.5
- 9.5x2 = 2x9.5
- 10x0.3 = 0.3x10
- 16x0.5 = 16x0.5
- 16x1 = 1x16

***) M = big transmitter optics with Ø 18 mm and big receiver optics with Ø 16 mm**

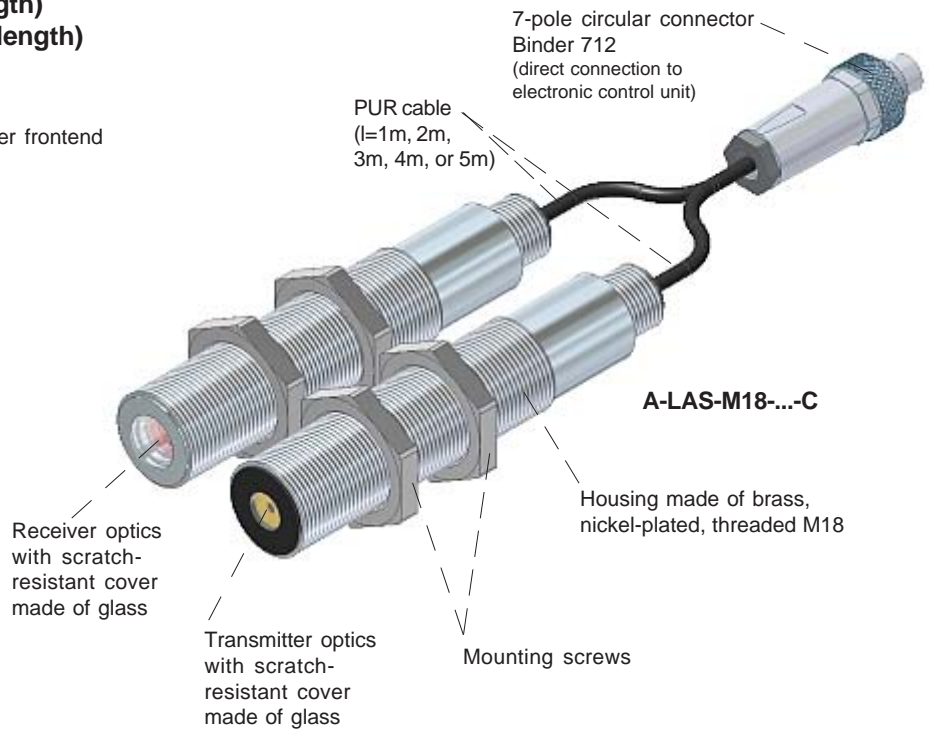

Available cable lengths:

(same cable length for transmitter and receiver frontend)

1m, 2m, 3m, 4m, or 5m

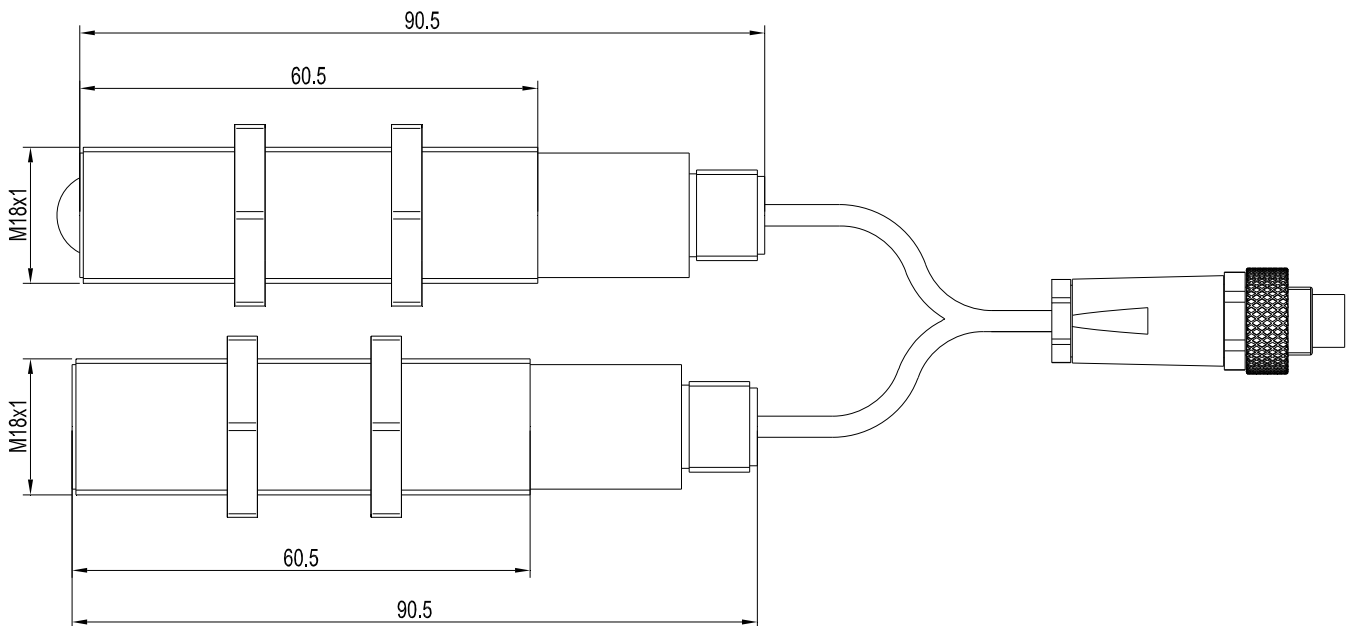

All dimensions in mm



Connector Assignment

**Connection SI-JET2-CON2 to PLC:
8-pole fem. connector Binder Series 712**

Pin:	Color:	Assignment:
1	white	GND (0V)
2	brown	+24VDC (±10%)
3	green	INO
4	yellow	OUT0
5	grey	OUT1
6	pink	OUT2
7	blue	OUT3
8	red	OUT4

Connecting cable:
cab-las8/SPS-(length)
cab-las8/SPS-w-(length) (angle type, 90°)
(standard length 2m)

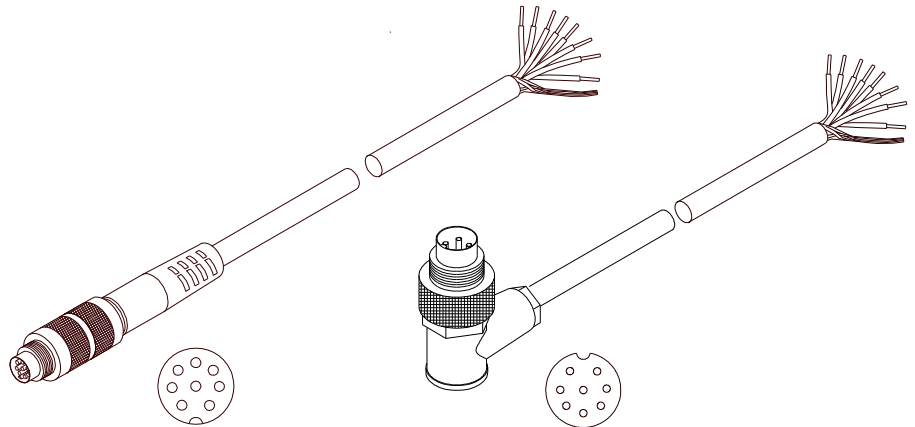

cab-las8/SPS-...
(max. length 25m, outer jacket: PUR)

cab-las8/SPS-w-...
(max. length 25m, outer jacket: PUR)

**Connection SI-JET2-CON2 to PC:
5-pole fem. connector Binder Series 712**

Pin:	Assignment:
1	GND (0V)
2	TxD
3	RxD
4	+24V (+Ub, OUT)
5	not connected

Connection via RS232 interface at the PC:

Connecting cable:
cab-las5/PC-(length)
cab-las5/PC-w-(length) (angle type 90°)
(standard length 2m)

alternative:

Connection via USB interface at the PC:

Connecting cable (incl. driver software):
cab-las5/USB-(length)
cab-las5/USB-w-(length) (angle type 90°)
(standard length 2m)

alternative:

Connection to local network via Ethernet bus:

Adapter (based on Lantronix XPortModul):
SI-RS232/Ethernet-5-(length)
(standard length 2m)

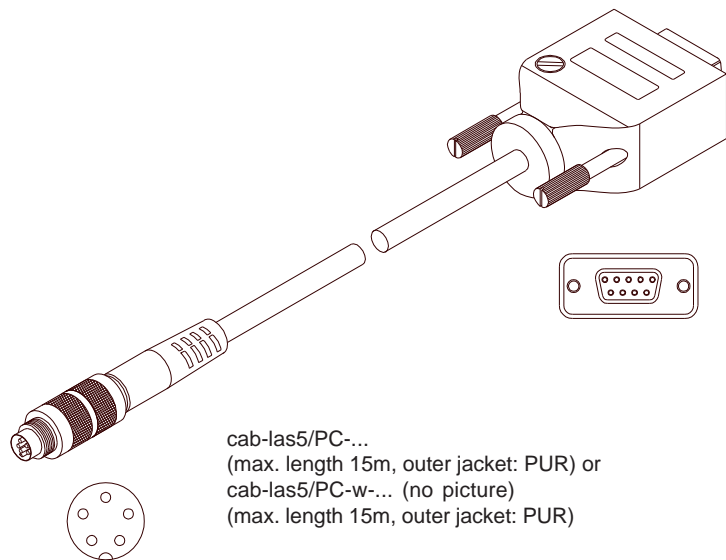

cab-las5/PC-...
(max. length 15m, outer jacket: PUR) or
cab-las5/PC-w-... (no picture)
(max. length 15m, outer jacket: PUR)

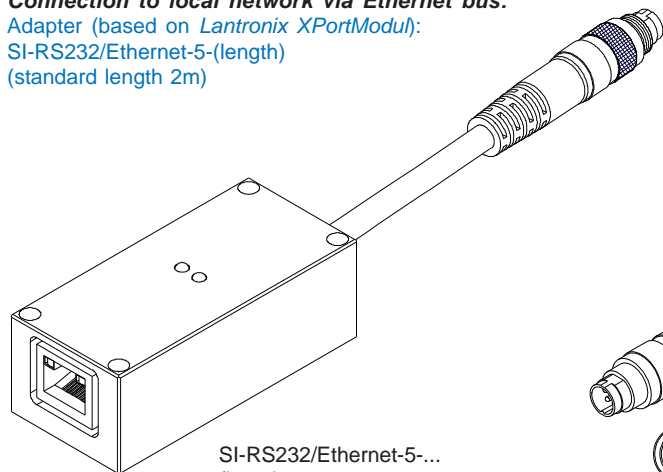

SI-RS232/Ethernet-5-...
(length 0,5m, 1m, or 2m,
outer jacket: PUR)

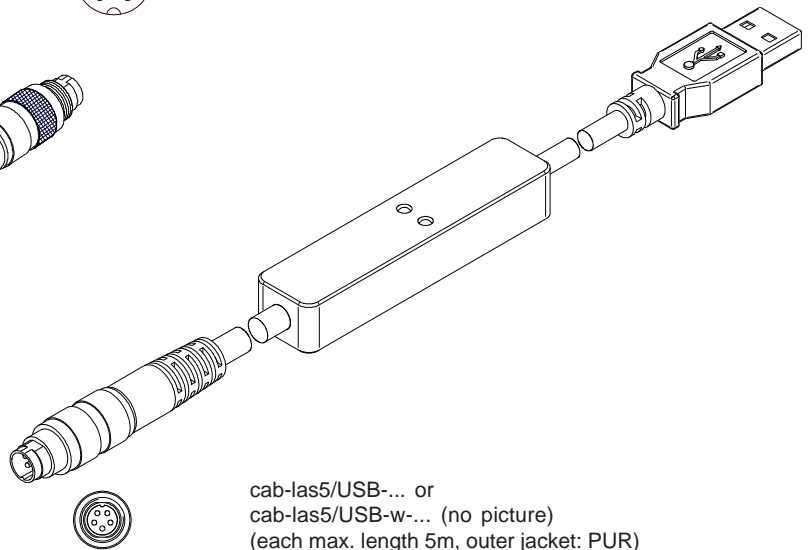

cab-las5/USB-... or
cab-las5/USB-w-... (no picture)
(each max. length 5m, outer jacket: PUR)



Settings

3x potentiometer for adjustment of gain:

Rotation clockwise: Increase of signal

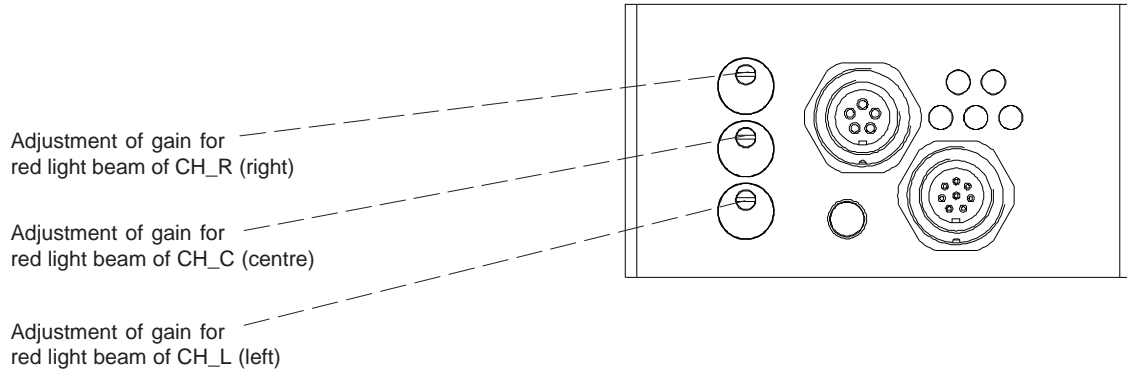



LED Display

LED display:

The line vector is visualised by way of 5 yellow LEDs at the housing of the SI-JET sensor. At the same time in the BINARY mode (OUTMODE BINARY) the line vector indicated on the LED display is output as 5-bit binary information at the digital outputs OUT0 to OUT4 of the 8-pole SI-JET/PLC female connector.

The SI-JET sensor is able to process a maximum of 31 line vectors (0 ... 30) in accordance with the corresponding lines in the TEACH TABLE. An "error" or a "not detected" is displayed by the lighting of all LED (OUT0 ... OUT4) digital outputs are set to HIGH-level).

In the DIRECT mode (OUTMODE DIRECT HI or OUTMODE DIRECT LO) the maximum numbers of line vectors to be taught is 5 (no. 0, 1, 2, 3,4).

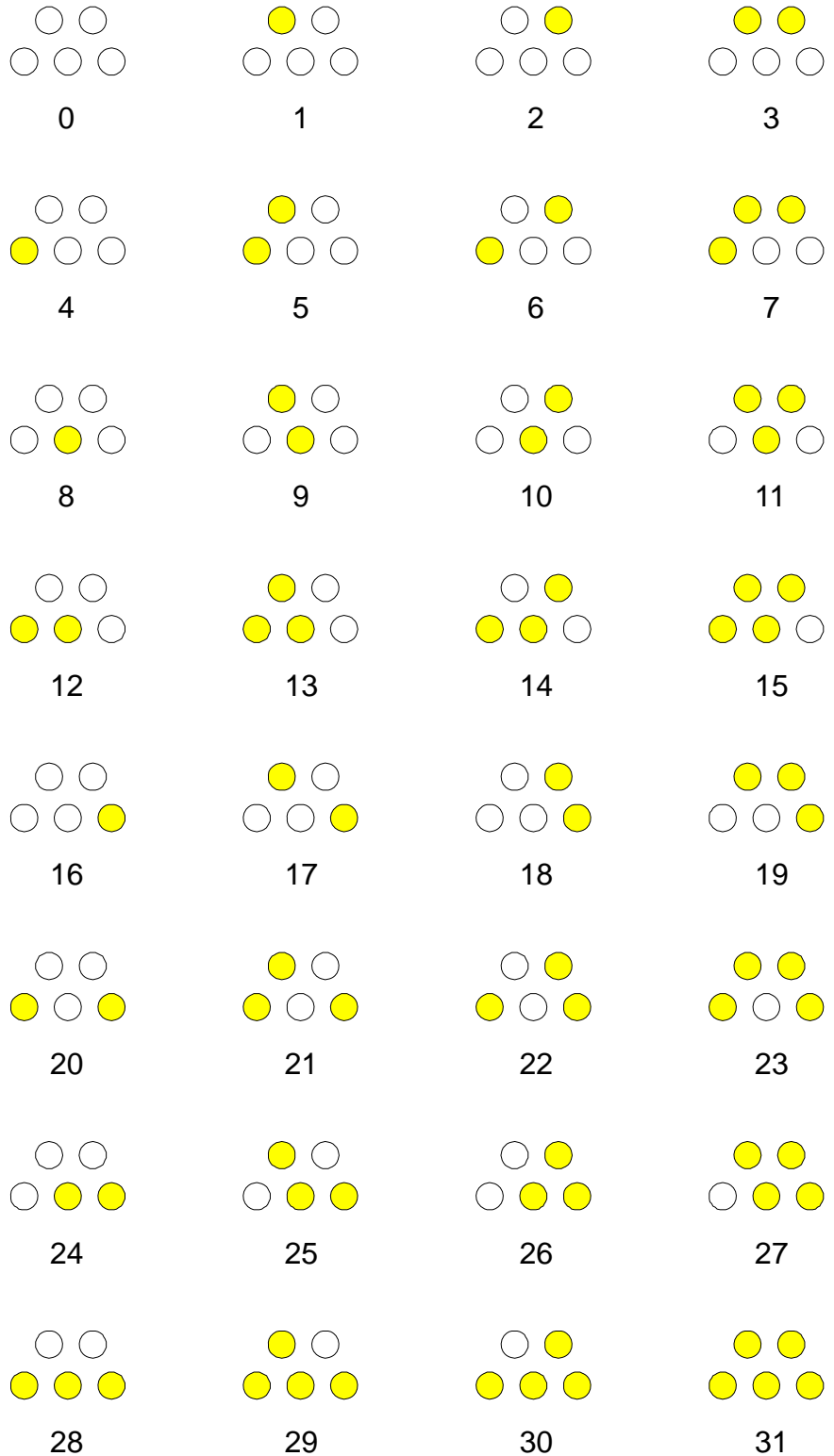

„Error“
or
„not detected“

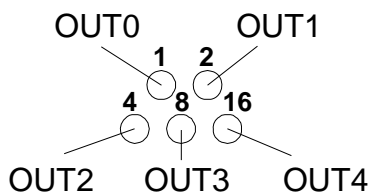
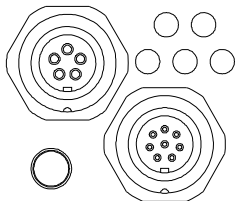



Measuring Principle
Measuring principle:

With the help of a super-bright red-light LED modulated light is aligned in parallel in the collimator optic unit. A suitable aperture technology ensures that three beams of red light (\varnothing 3 mm each, 5 mm distance to each other) leave the transmitting branch of the transmitter, and at the receiving side are again directed onto three receiving optical-fibers by mean of 3 apertures with suitable receiving optics.

By means of the optoelectronic detectors, the three light signals are converted into three electronic signals and are digitised by way of 12-bit-A/D-converters. When a spray jet now crosses the path of the three red light beams, the respective light beams are attenuated due to light absorption and/or light deflection at the droplets contained in the spray jet. The degree of attenuation of the respective signal is a measure for the droplet contraction at the place of the light beam.



Parameterization
Parameterization under Windows® with software SI-JET-Scope:

The following three measurands are picked up and monitored in the production process by the SI-JET spray jet monitoring system:

- Spray jet density (average of the 3 red light parts CH_L, CH_C, CH_R)
- Symmetry 1 (the two outer channels are put into proportion to each other)
- Symmetry 2 (Symmetry 1 is put into proportion to the centre channel)

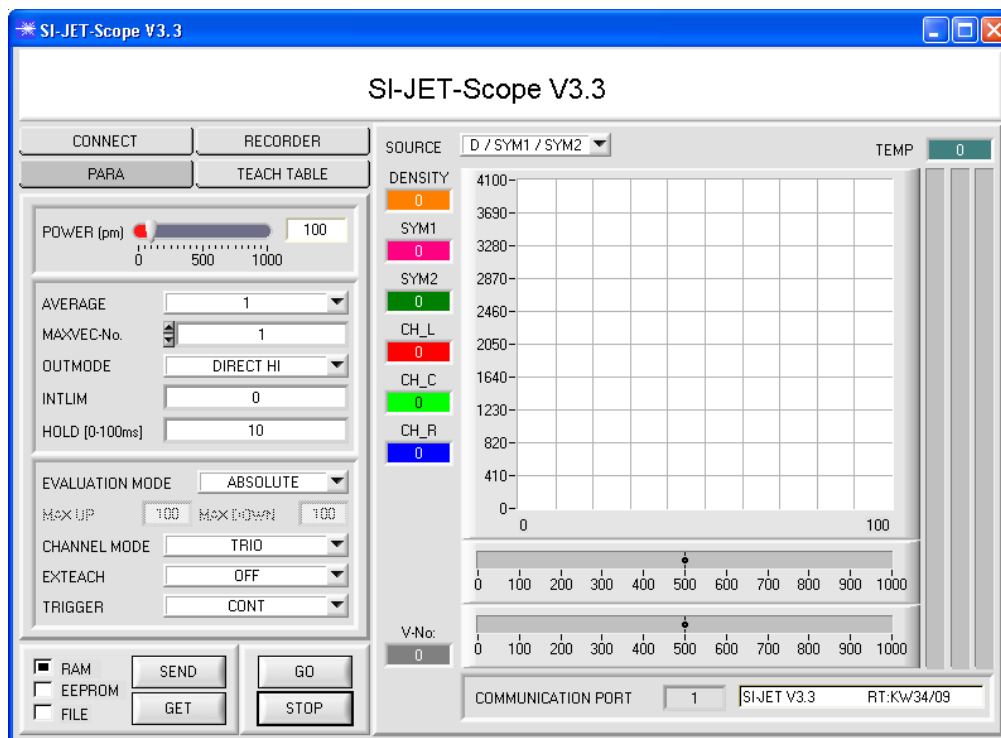
**Evaluation modes:**

The SI-JET can be operated with two different evaluation modes.

ABSOLUTE: The absolute status of the three channels CH_L, CH_C, and CH_R is used for evaluation.

RELATIVE: The current status of the three channels CH_L, CH_C, and CH_R relative to their maximum values in the last 60 seconds is used for evaluation.

TEACH process:

The teach process can be performed either with the parameterisation software, by way of the teach input (IN0 PIN3 green at the cab-las8/SPS cable), or by means of the switch at the housing. When teaching is performed through the IN0 input, the tolerance values for density and symmetry must first be stored once in the EEPROM of the control unit with the help of the parameterisation software. Before input IN0 is activated, the status to be taught must be present at the sensor front-end, i.e. spraying must first be switched on, and then IN0 must be set to +24V.

The current status is taught to as many rows in the Teach Table as have been selected under MAXVEC-No. Classification is performed by way of different set tolerances.



Data Recorder

Function of the data recorder:

The SI-JET-Scope software features a data recorder that makes it possible to save a certain number of data frames. The recorded file is saved to the hard disk of the PC and can then be evaluated with a spreadsheet program.

The created file has eight columns and as many rows as data frames were recorded. A row is structured as follows: Date and time, CH_L, CH_C, CH_R, DENSITY, SYM1, SYM2, TEMP.

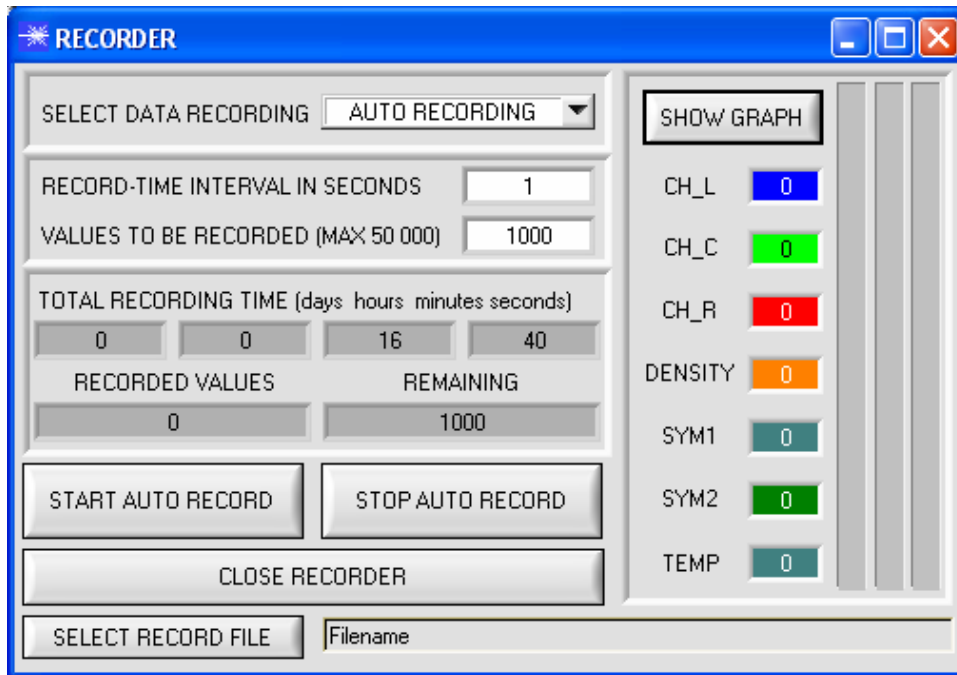

Accessories

Blast air top parts for A-LAS-M12:

(please order separately)

ABL-M12-3 (air outlet \varnothing 3 mm)

ABL-M12-10 (air outlet \varnothing 10 mm)

suitable for sensor frontend A-LAS-M12-...-C



ABL-M12-3



ABL-M12-10

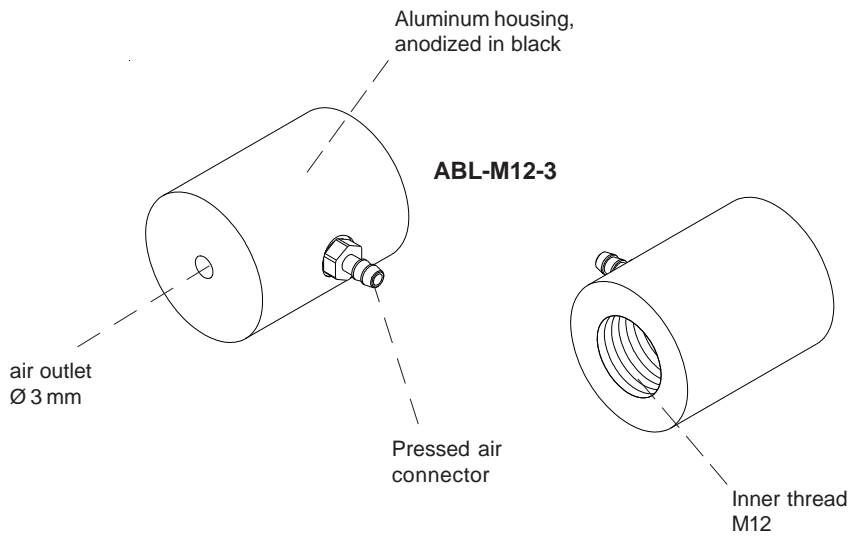

ABL-M12-3

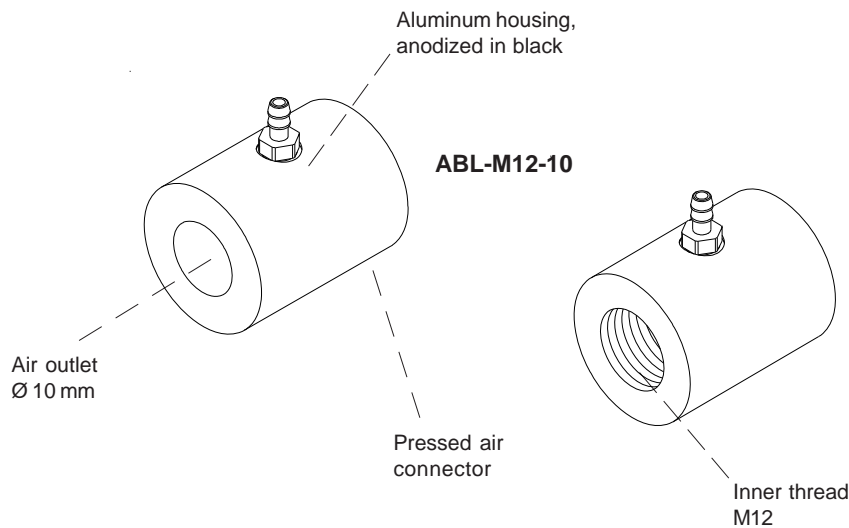
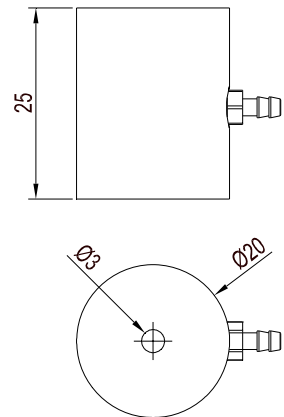

ABL-M12-10

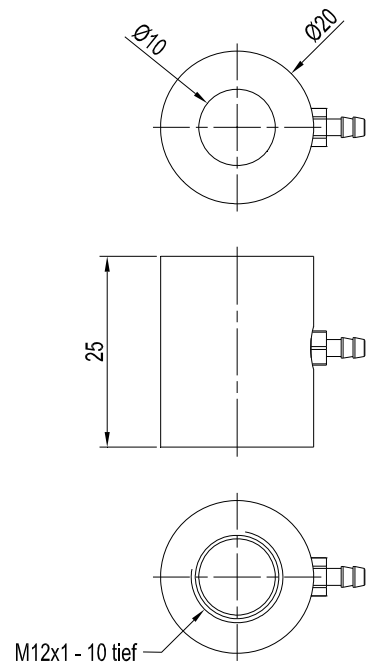

All dimensions in mm



Accessories

Blast air top part for A-LAS-M18:

(please order separately)

ABL-M18-3 (air outlet \varnothing 3 mm)

ABL-M18-5 (air outlet \varnothing 5 mm)

ABL-M18-10 (air outlet \varnothing 10 mm)

suitable for sensor frontend A-LAS-M18-...-C

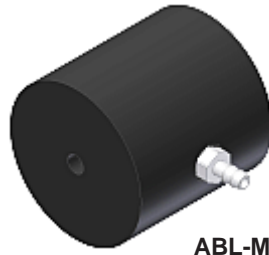

ABL-M18-3



ABL-M18-5



ABL-M18-10

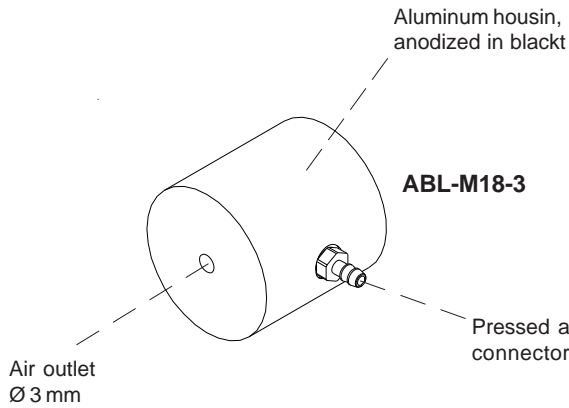

ABL-M18-3

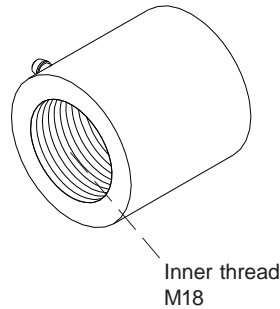

Inner thread M18

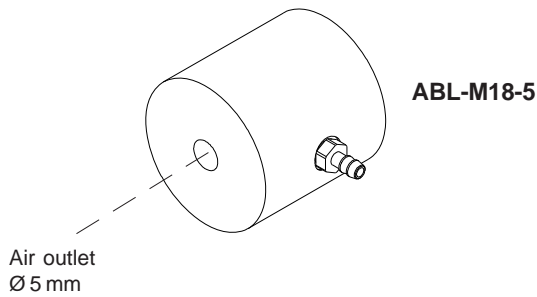

ABL-M18-5

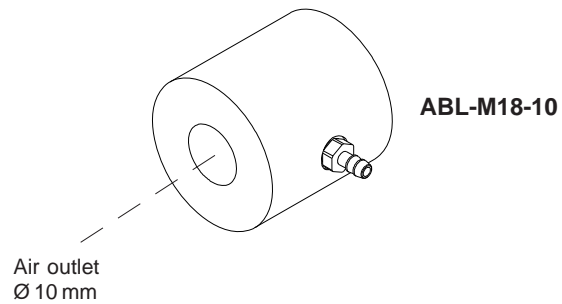

ABL-M18-10

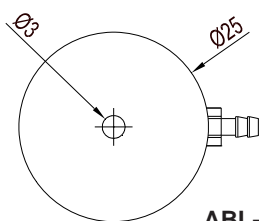

ABL-M18-3

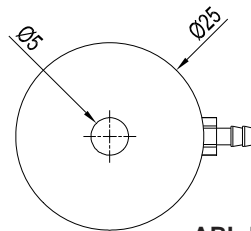

ABL-M18-5

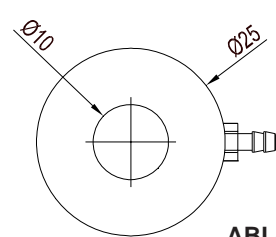

ABL-M18-10

All dimensions in mm

Accessories

Mounting accessories:

(please order separately)

FL-12 (flange)

WFL-12 (flange angle type 90°)

suitable for sensor frontend
A-LAS-M12-...-T-C and
A-LAS-M12-...-R-C

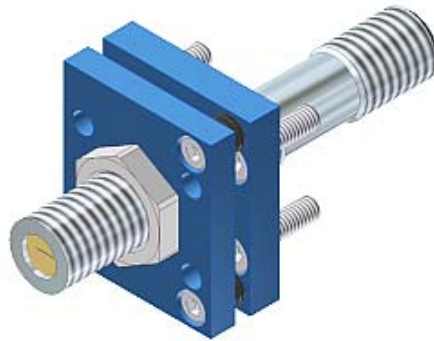

FL-M12
(picture with A-LAS-M12)

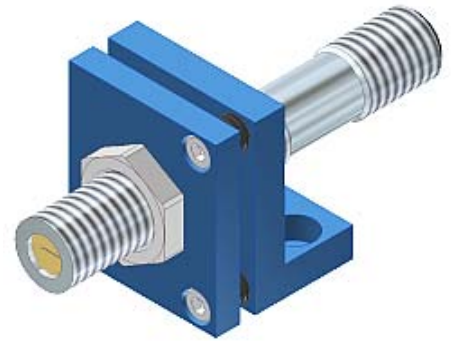

WFL-M12
(picture with A-LAS-M12)

FL-12

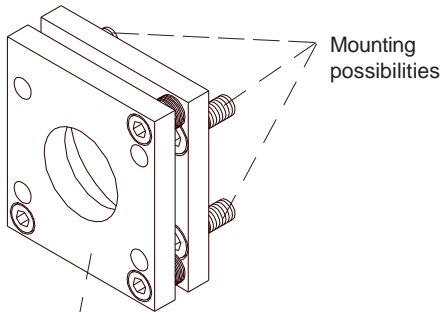

Mounting possibilities

Sturdy material
(aluminum)

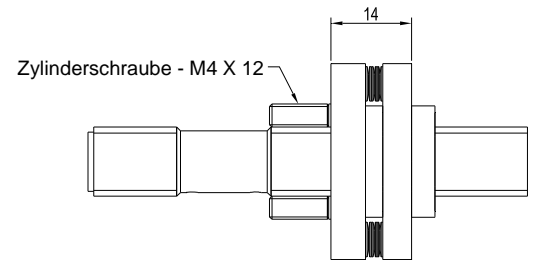
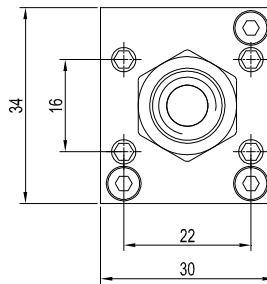

WFL-12

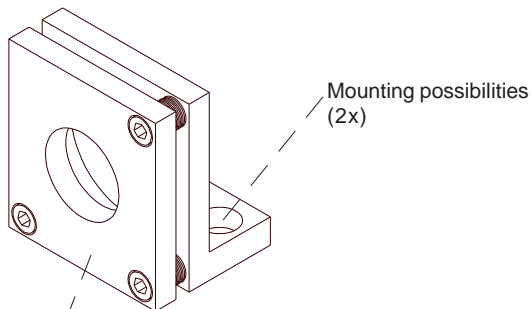

Mounting possibilities
(2x)

Sturdy material
(aluminum)

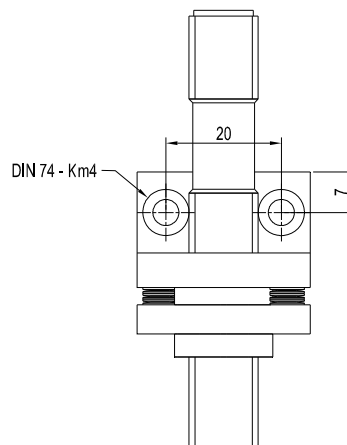
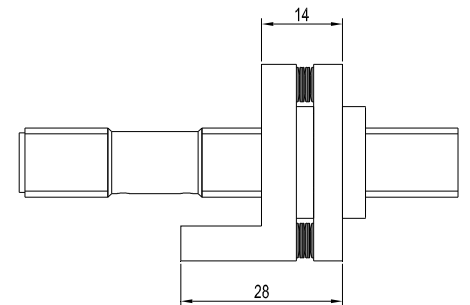
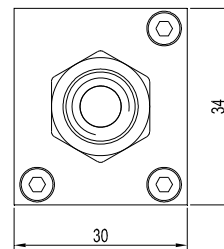

All dimensions in mm

Accessories

Mounting accessories:

(please order separately)

FL-18 (flange)

WFL-18 (flange angle type 90°)

suitable for sensor frontend
A-LAS-M18-...-T-C and
A-LAS-M18-...-R-C

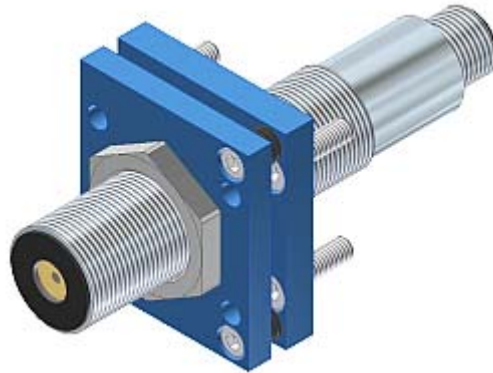

FL-M18
(picture with A-LAS-M18)

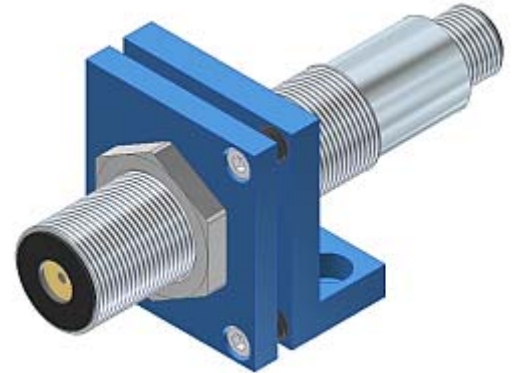

WFL-M18
(picture with A-LAS-M18)

FL-18

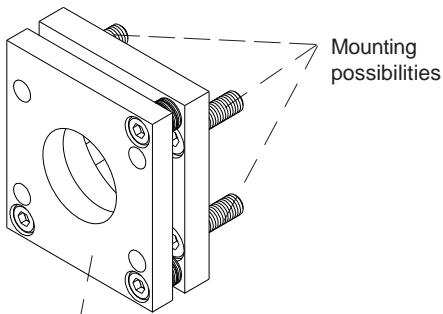

Sturdy material
(aluminum)

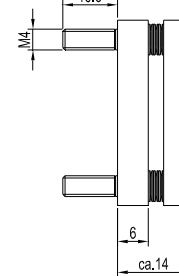
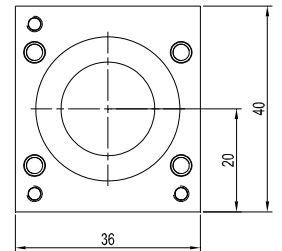
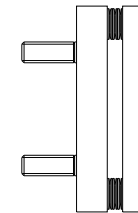
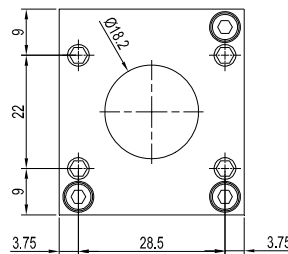

WFL-18

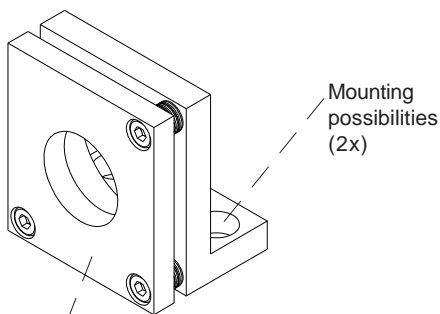

Sturdy material
(aluminum)

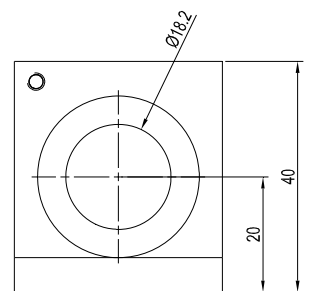
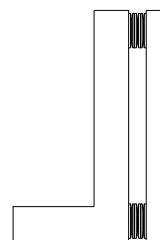

DIN 74 - Km4

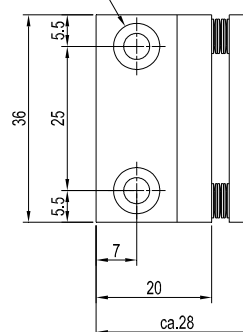

All dimensions in mm



Sensor Instruments