

In Proud Partnership with Sensor Instruments

**PAQUIN**  
SENSORS

For technical support, sales, & distribution  
within the USA & Canada

www.paquin.com | (800) 831-8217 | paquinsensors@paquin.com

# SI-JET Series

## ▶ SI-JET3-CON5 SI-JET3-d12

By way of the three red light beams, the SI-JET3 Spray Jet Monitoring System monitors the density and the symmetry around the opening angle of the spray jet. With the comprehensive SI-JET-Scope software the system can be parameterised under Windows®.

- Telecentric design enables a big transmitter/receiver distance
- Insensitive to dirt accumulation due to pressed air facility (at transmitter and receiver side)
- Averaging can be adjusted (over 32000 values)
- RS232 interface (USB or Ethernet adaptor is available)
- Windows® user interface
- Various teach possibilities (teach button, PLC, PC)
- Insensitive to outside light due to clocked red light LED (30 kHz)
- High dynamic range (due to light power adjustment of LED via RS232)
- High resolution (12-bit-A/D-converter)

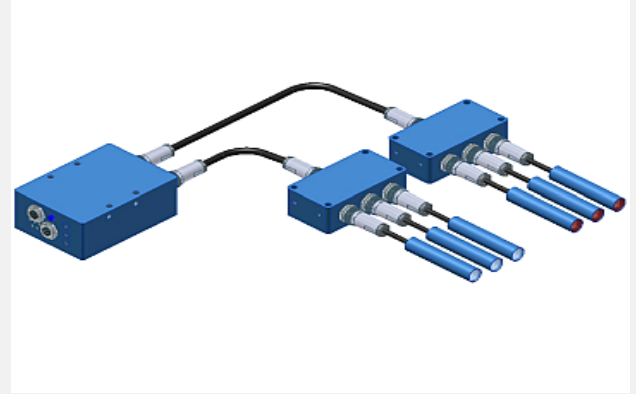

### Design

**Product name:**

- SI-JET3-CON5** (Electronic control unit, incl. Windows® PC software SI-JET-Scope)
- SI-JET3-d12-T** (Transmitter frontend)
- SI-JET3-d12-R** (Receiver frontend)
- SI-JET-MUX-3/3** (Distributor box 3-fold for transmitter)
- SI-JET-MUX-3/7** (Distributor box 3-fold for receiver)

**Accessories:** (s. page 13):

**ABL-SI-JET3-d12** (Blast air top part)

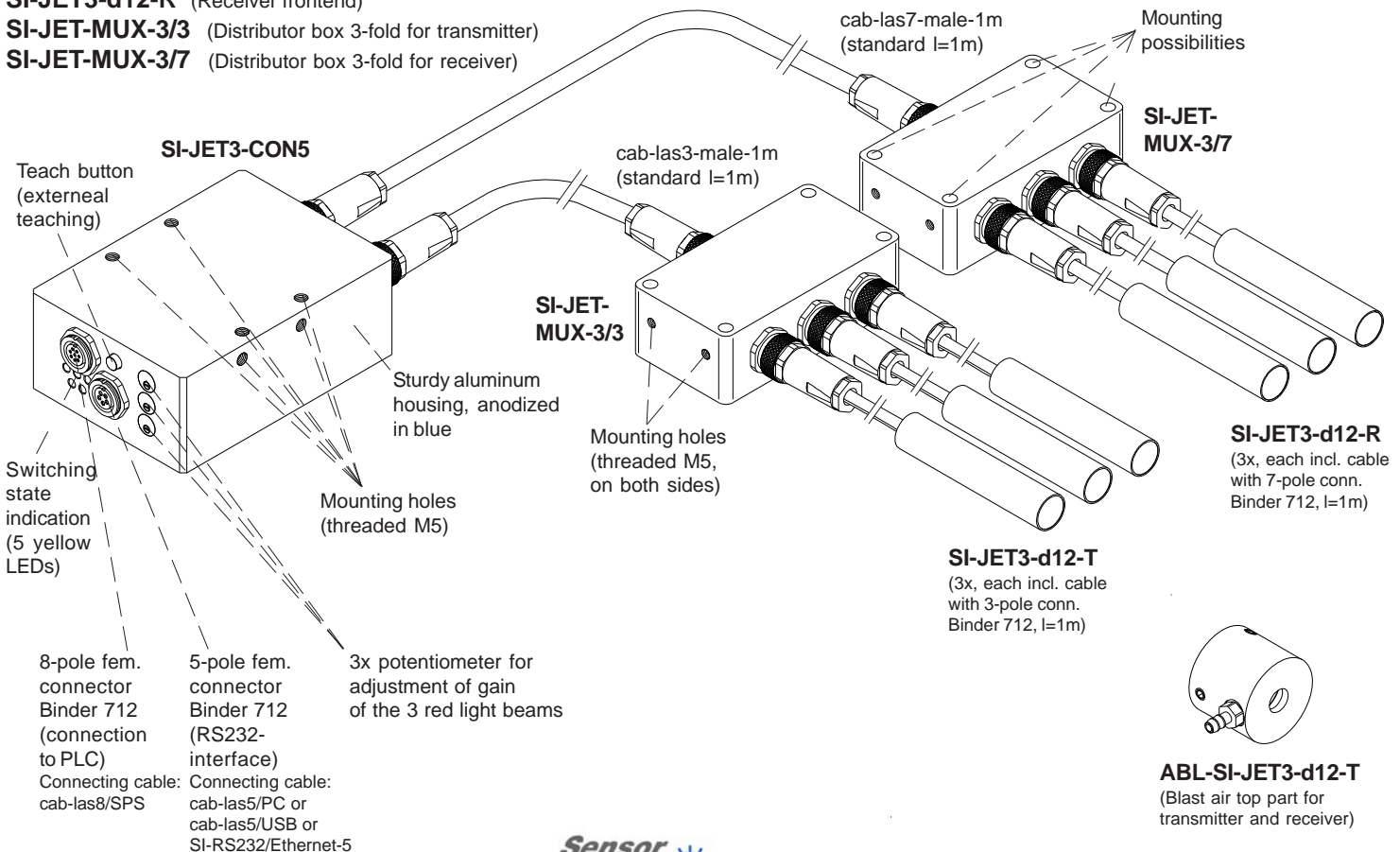



**Technical Data**

| Model                      | <b>SI-JET3-CON5 (electronic control unit)</b>  |
|----------------------------|--|
| Voltage supply             | +24VDC (± 10%), reversed-polarity protected, overload protected  |
| Current consumption        | typ. 200 mA  |
| Operating temperature      | -10°C ... 50°C   |
| Enclosure rating           | IP64   |
| Housing material           | Aluminum, anodized in blue   |
| Housing dimensions         | approx. 80 mm x 65 mm x 30 mm (without connectors)   |
| Type of connector          | Connection to PC: 5-pole female connector type Binder 712<br>Connection to PLC: 8-pole female connector type Binder 712<br>Connection to frontend, transmitter side: 3-pole female connector type Binder 712<br>Connection to frontend, receiver side: 7-pole female connector type Binder 712 |
| Transmitter                | Super bright LED (red, 650 nm), modulated 30 kHz   |
| External teaching          | by means of an integrated push-button  |
| Switching state indication | by means of 5 yellow LEDs  |
| Interface                  | RS232, parameterizable under Windows®  |
| Averaging                  | adjustable under Windows: max. 32768 values  |
| Outputs                    | OUT0 ... OUT4, digital (0V/+U <sub>B</sub> ), short-circuit-proof, 100 mA max. switching current;<br>npn- or pnp-capable (bright- and dark-switching can be adjusted)  |
| External teach input IN0   | +U <sub>B</sub> -Signal (min. pulse length 250 ms, max. pulse length 1000 ms)  |
| Pulse lengthening          | adjustable under Windows®: 0 ms .. 100 ms  |
| EMV test acc. to           | DIN EN 60947-5-2   |

| Model                              | <b>SI-JET3-d12-T (transmitter frontend) + SI-JET3-d12-R (receiver frontend)</b>   |
|------------------------------------|---|
| Max. distance transmitter/receiver | typ. 1500 mm  |
| Red light beam alignment           | Telecentrical, typ. Ø 5 mm at light outlet at transmitter side (with blast air top part)                                      |
| Optisches Filter                   | Rotlichtfilter RG630  |
| Beam divergency                    | typ. 10 mrad  |
| Enclosure rating                   | IP 67   |
| Working temperature range          | -10°C ... +50°C   |
| Storage temperature range          | -20°C ... +85°C   |
| Housing material                   | aluminum, anodized in blue  |
| Housing dimensions                 | cylindrical, L x Ø approx. 60 mm x 12 mm  |
| Type of connector                  | at transmitter side: 3-pole circular connector type Binder 712<br>at receiver side: 7-pole circular connector type Binder 712 |
| Pressed air connector              | at transmitter and receiver side  |



**System Components**

Electronic control unit, distributor boxes and sensor frontends

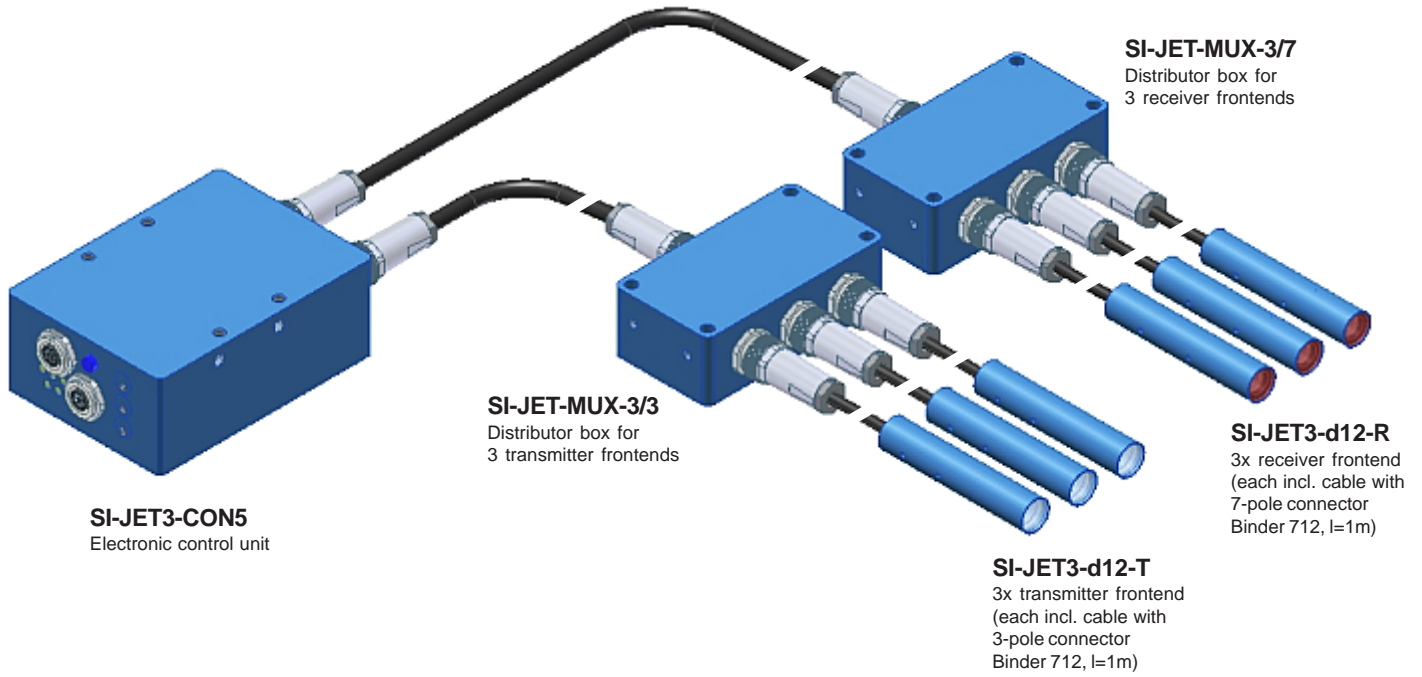

Assembly sketch:

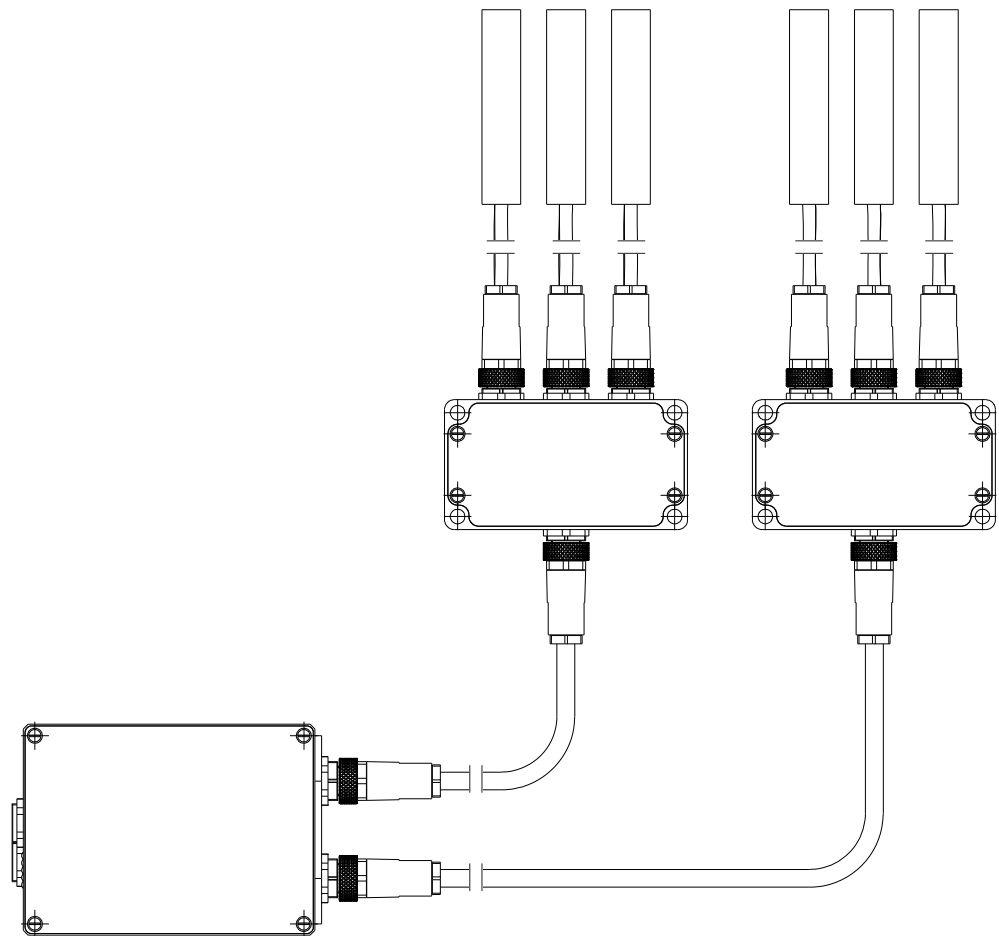



Dimensions

**SI-JET3-d12-T**  
(Transmitter frontend)

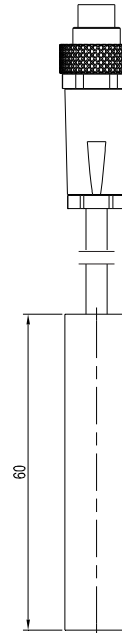
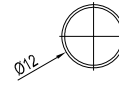
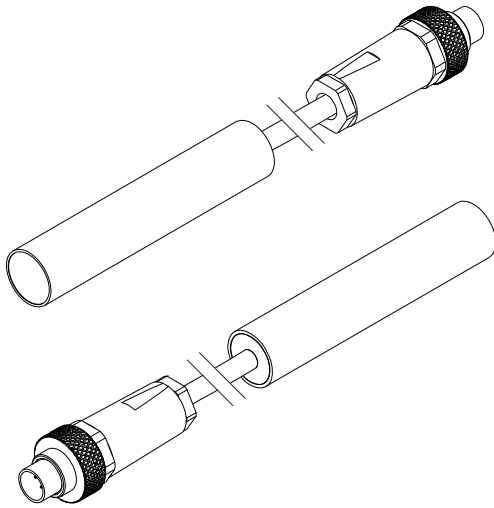

**SI-JET3-d12-R**  
(Receiver frontend)

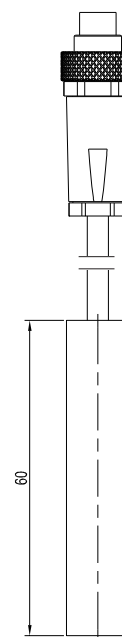
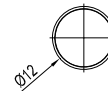
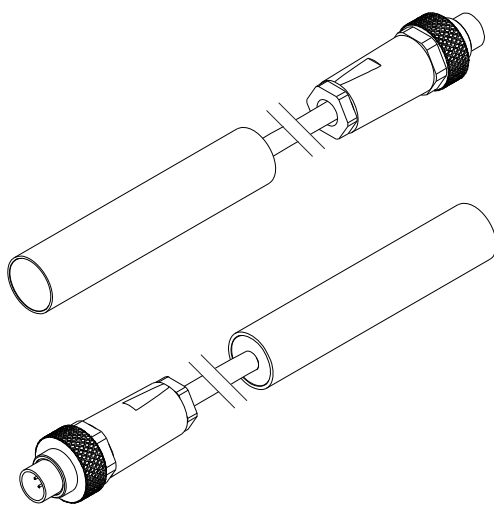

All dimensions in mm

Dimensions

**SI-JET-MUX-3/3**

(Distributor box for transmitters)

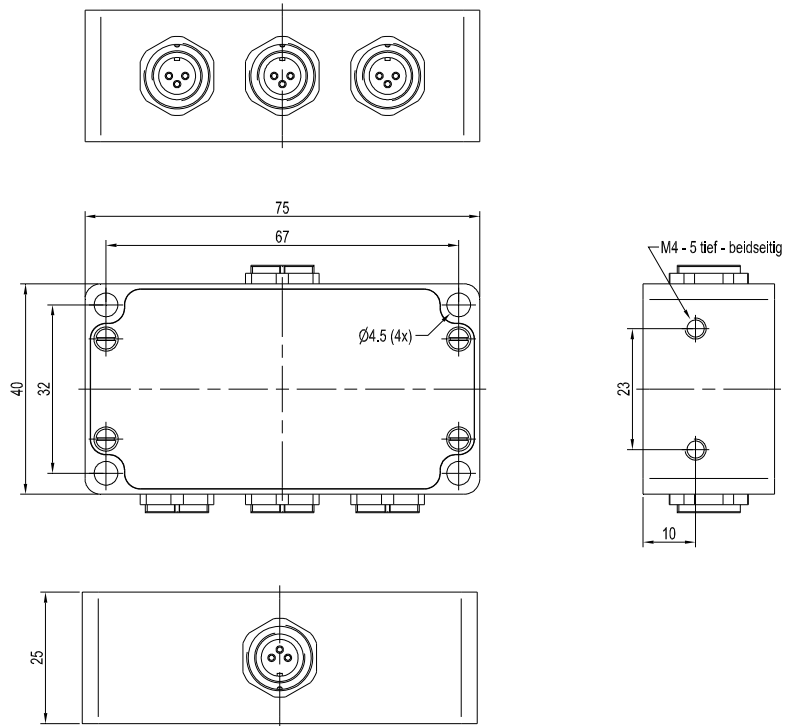
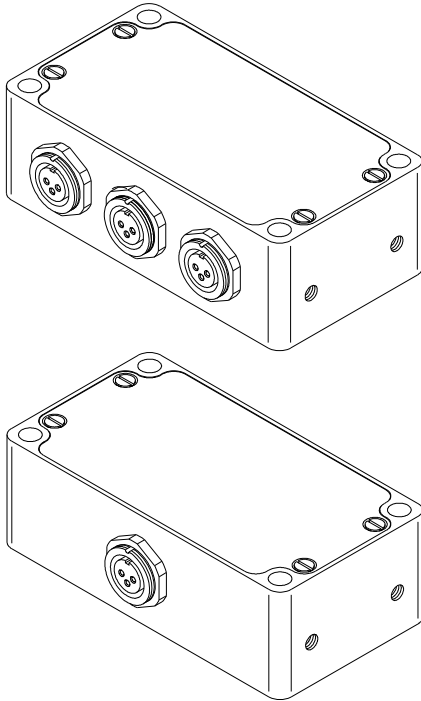

**SI-JET-MUX-3/7**

(Distributor box for receivers)

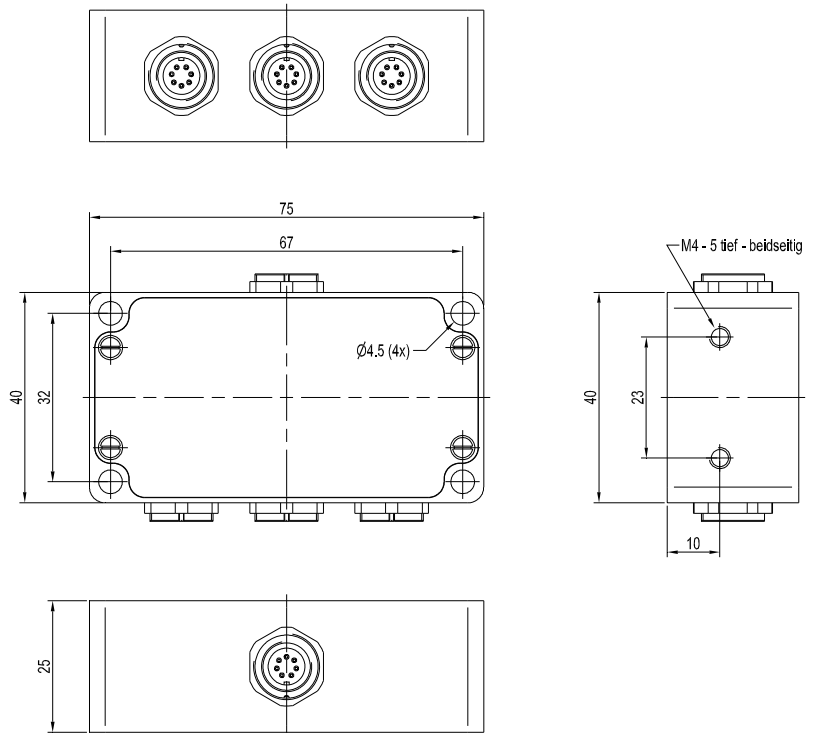
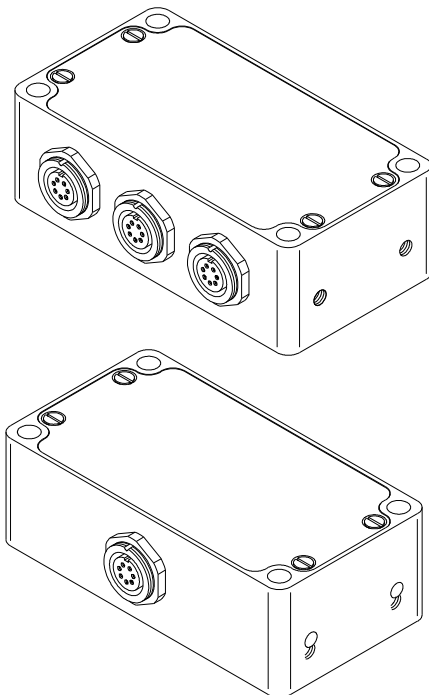

All dimensions in mm



Dimensions

**SI-JET3-CON5**  
(Electronic control unit)

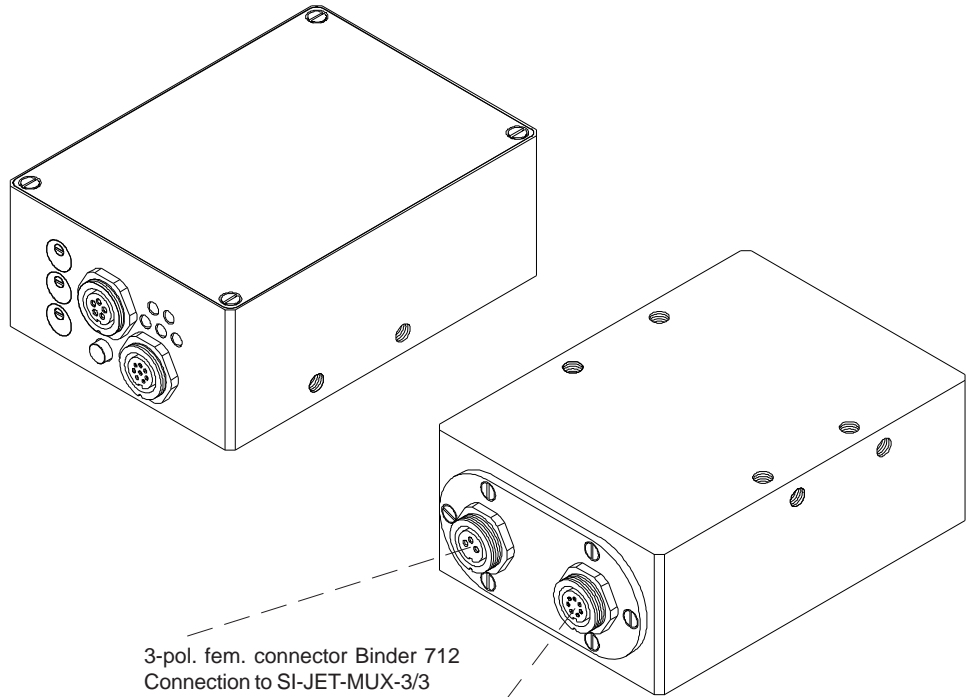

3-pol. fem. connector Binder 712  
Connection to SI-JET-MUX-3/3  
Connecting cable:  
cab-las3-male-...

7-pole fem. connector Binder 712  
Connection to SI-JET-MUX-3/7  
Connecting cable:  
cab-las7-male-...

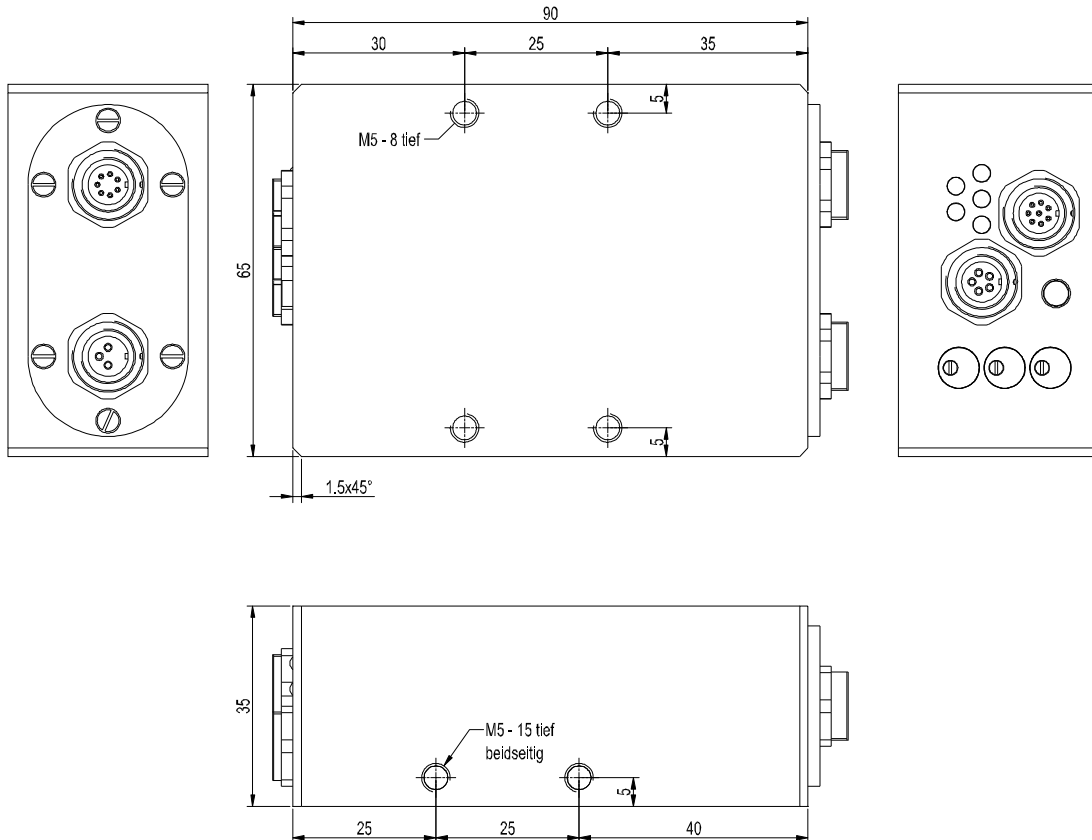

All dimensions in mm



## Connector Assignment

### Connection SI-JET3-CON5 to PLC: 8-pole fem. connector Binder Series 712

| Pin: | Color: | Assignment:           |
|------|--------|-----------------------|
| 1    | white  | GND (0V)              |
| 2    | brown  | +24VDC ( $\pm 10\%$ ) |
| 3    | green  | INO                   |
| 4    | yellow | OUT0                  |
| 5    | grey   | OUT1                  |
| 6    | pink   | OUT2                  |
| 7    | blue   | OUT3                  |
| 8    | red    | OUT4                  |

Connecting cable:  
cab-las8/SPS-(length)  
cab-las8/SPS-w-(length) (angle type, 90°)  
(standard length 2m)

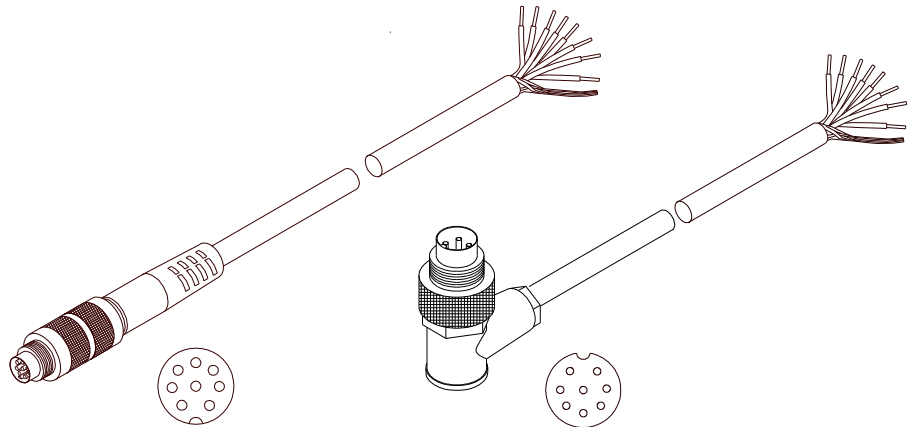

cab-las8/SPS-...  
(max. length 25m, outer jacket: PUR)

cab-las8/SPS-w-...  
(max. length 25m, outer jacket: PUR)

### Connection SI-JET3-CON5 to PC: 5-pole fem. connector Binder Series 712

| Pin: | Assignment:     |
|------|-----------------|
| 1    | GND (0V)        |
| 2    | TxD             |
| 3    | RxD             |
| 4    | +24V (+Ub, OUT) |
| 5    | not connected   |

#### Connection via RS232 interface at the PC:

Connecting cable:  
cab-las5/PC-(length)  
cab-las5/PC-w-(length) (angle type 90°)  
(standard length 2m)

#### alternative:

#### Connection via USB interface at the PC:

Connecting cable (incl. driver software):  
cab-las5/USB-(length)  
cab-las5/USB-w-(length) (angle type 90°)  
(standard length 2m)

#### alternative:

#### Connection to local network via Ethernet bus:

Adapter (based on Lantronix XPortModul):  
SI-RS232/Ethernet-5-(length)  
(standard length 2m)

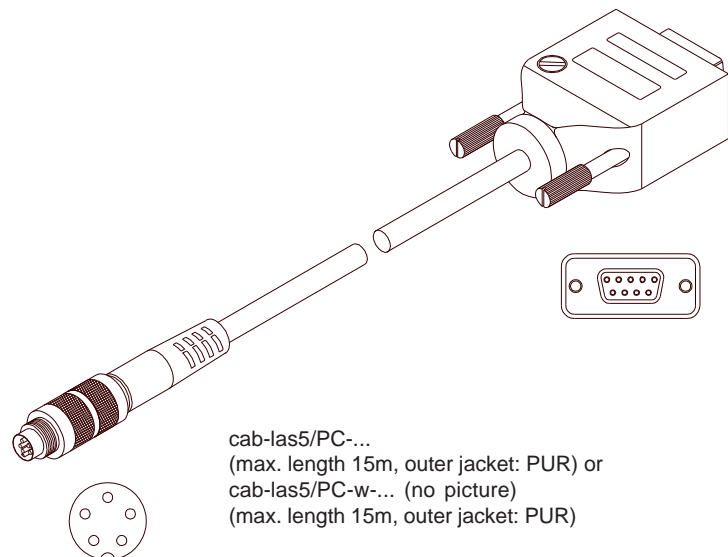

cab-las5/PC-...  
(max. length 15m, outer jacket: PUR) or  
cab-las5/PC-w-... (no picture)  
(max. length 15m, outer jacket: PUR)

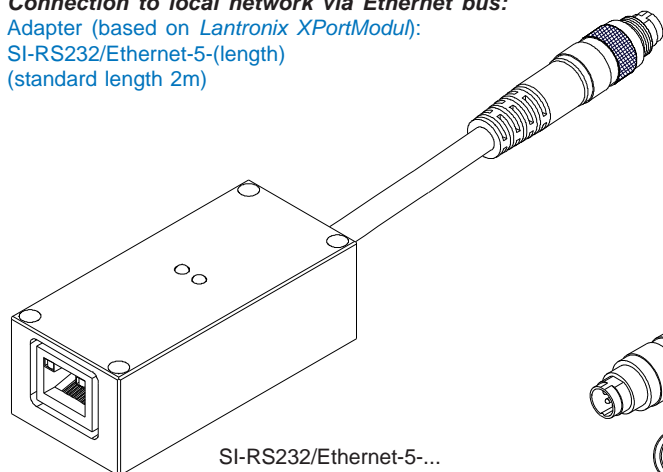

SI-RS232/Ethernet-5-...  
(length 0,5m, 1m, or 2m,  
outer jacket: PUR)

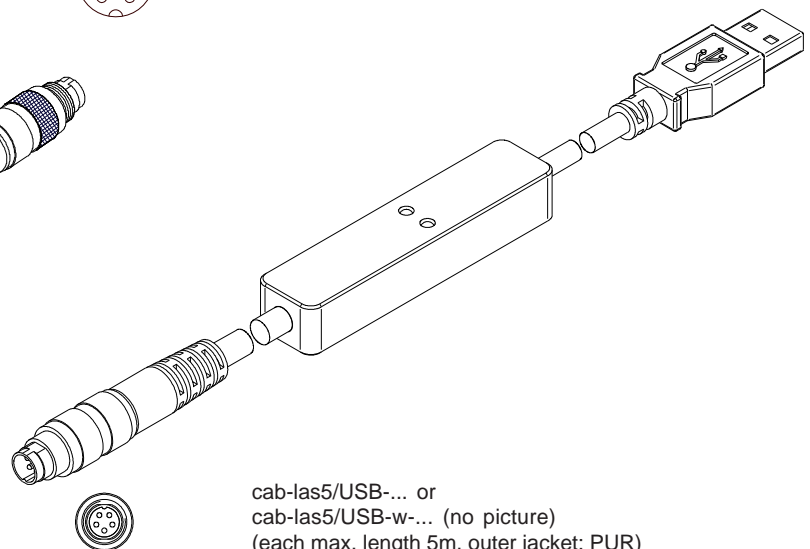

cab-las5/USB-... or  
cab-las5/USB-w-... (no picture)  
(each max. length 5m, outer jacket: PUR)



## Connector Assignment

### Connection SI-JET3-CON5 to SI-JET-MUX-3/3 (and connection SI-JET-MUX-3/3 to SI-JET3-d12-T): 2x 3-pole circular connector type Binder Series 712

| Pin: | Assignment:   |
|------|---------------|
| 1    | LED anode     |
| 2    | LED cathode   |
| 3    | not connected |

Connection cable  
for connection of SI-JET3-CON5 to SI-JET-MUX-3/3:  
cab-las3-male-(length)  
(standard length 1m)

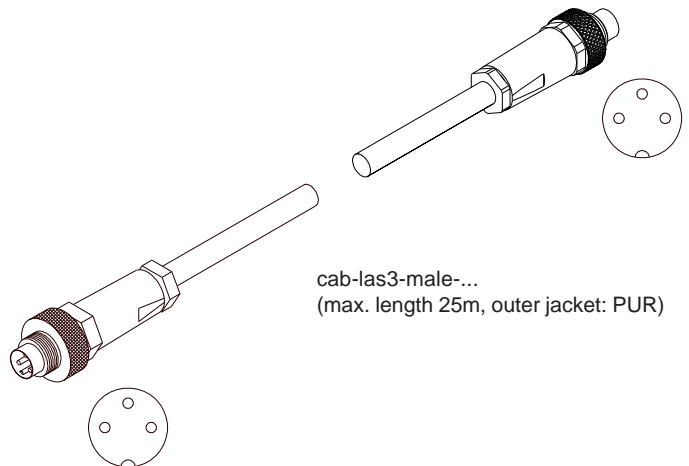

### Connection SI-JET3-CON5 to SI-JET-MUX-3/7 (and connection SI-JET-MUX-3/7 to SI-JET3-d12-R): 2x 7-pole circular connector type Binder Series 712

| Pin: | Assignment:        |
|------|--------------------|
| 1    | 0V                 |
| 2    | +Ub (+24VDC ± 10%) |
| 3    | ANA1               |
| 4    | ANA2               |
| 5    | ANA3               |
| 6    | 0V                 |
| 7    | not connected      |

Connecting cable  
for connection of SI-JET3-CON5 to SI-JET-MUX-3/7:  
cab-las7-male-(length)  
(standard length 1m)

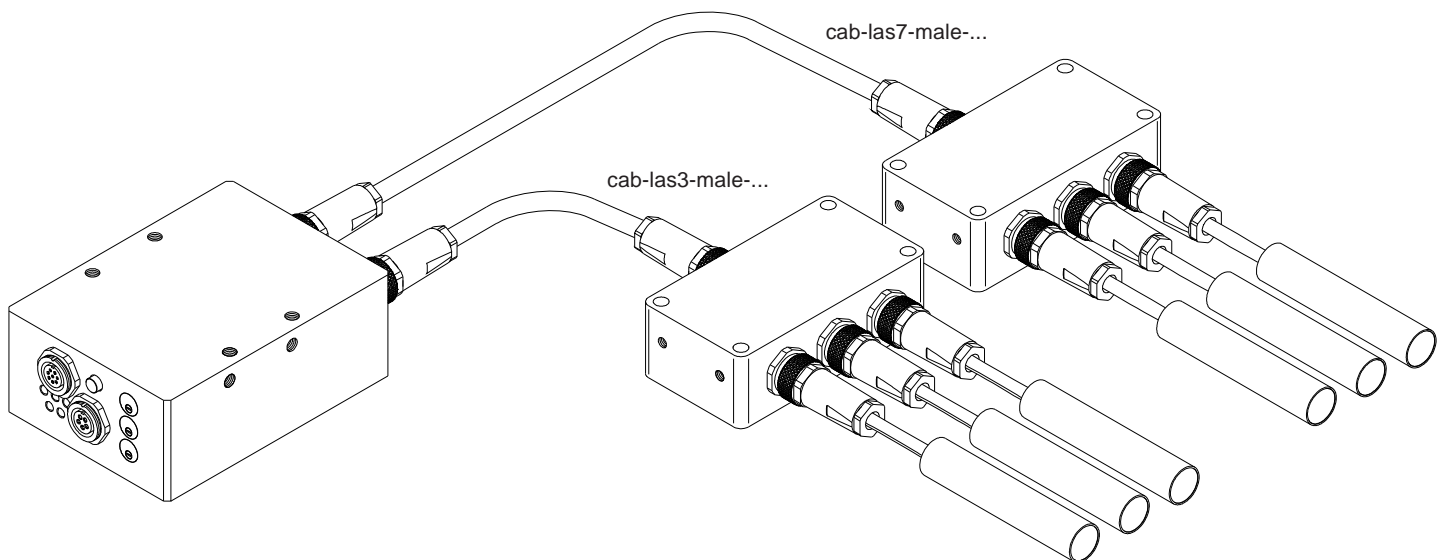
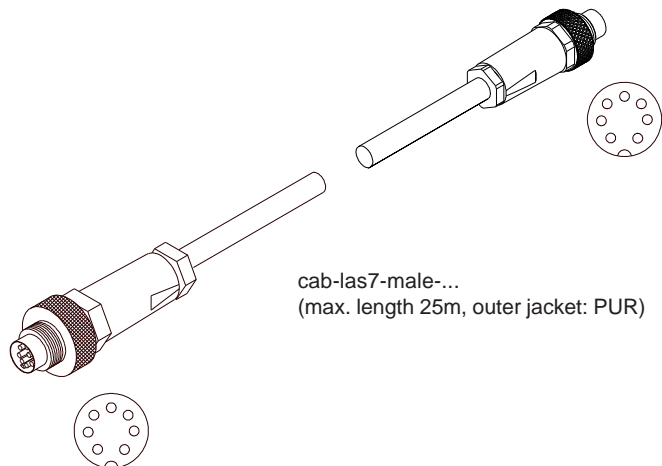





Settings

**Potentiometer for adjustment of gain:**

Rotation clockwise: Increase of signal

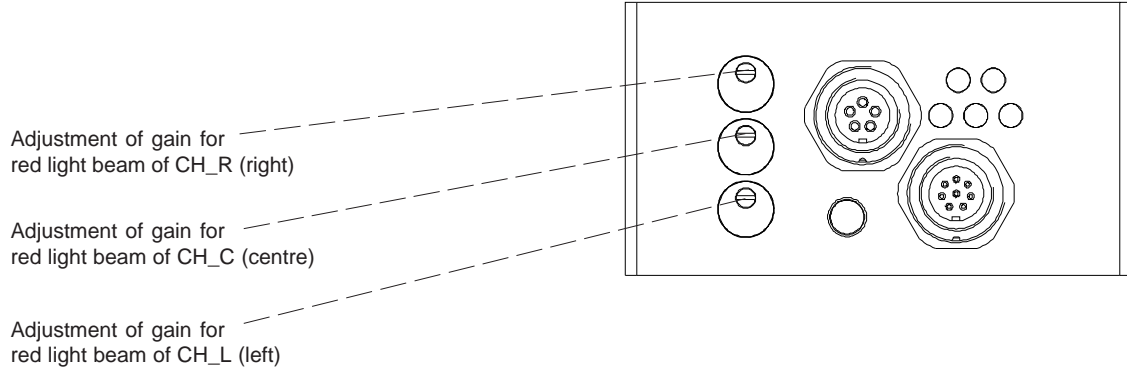



LED Display

**LED display:**

The line vector is visualised by way of 5 yellow LEDs at the housing of the SI-JET sensor. At the same time in the BINARY mode (OUTMODE BINARY) the line vector indicated on the LED display is output as 5-bit binary information at the digital outputs OUT0 to OUT4 of the 8-pole SI-JET/PLC female connector.

The SI-JET sensor is able to process a maximum of 31 line vectors (0 ... 30) in accordance with the corresponding lines in the TEACH TABLE. An "error" or a "not detected" is displayed by the lighting of all LED (OUT0 ... OUT4) digital outputs are set to HIGH-level).

In the DIRECT mode (OUTMODE DIRECT HI or OUTMODE DIRECT LO) the maximum numbers of line vectors to be taught is 5 (no. 0, 1, 2, 3,4).

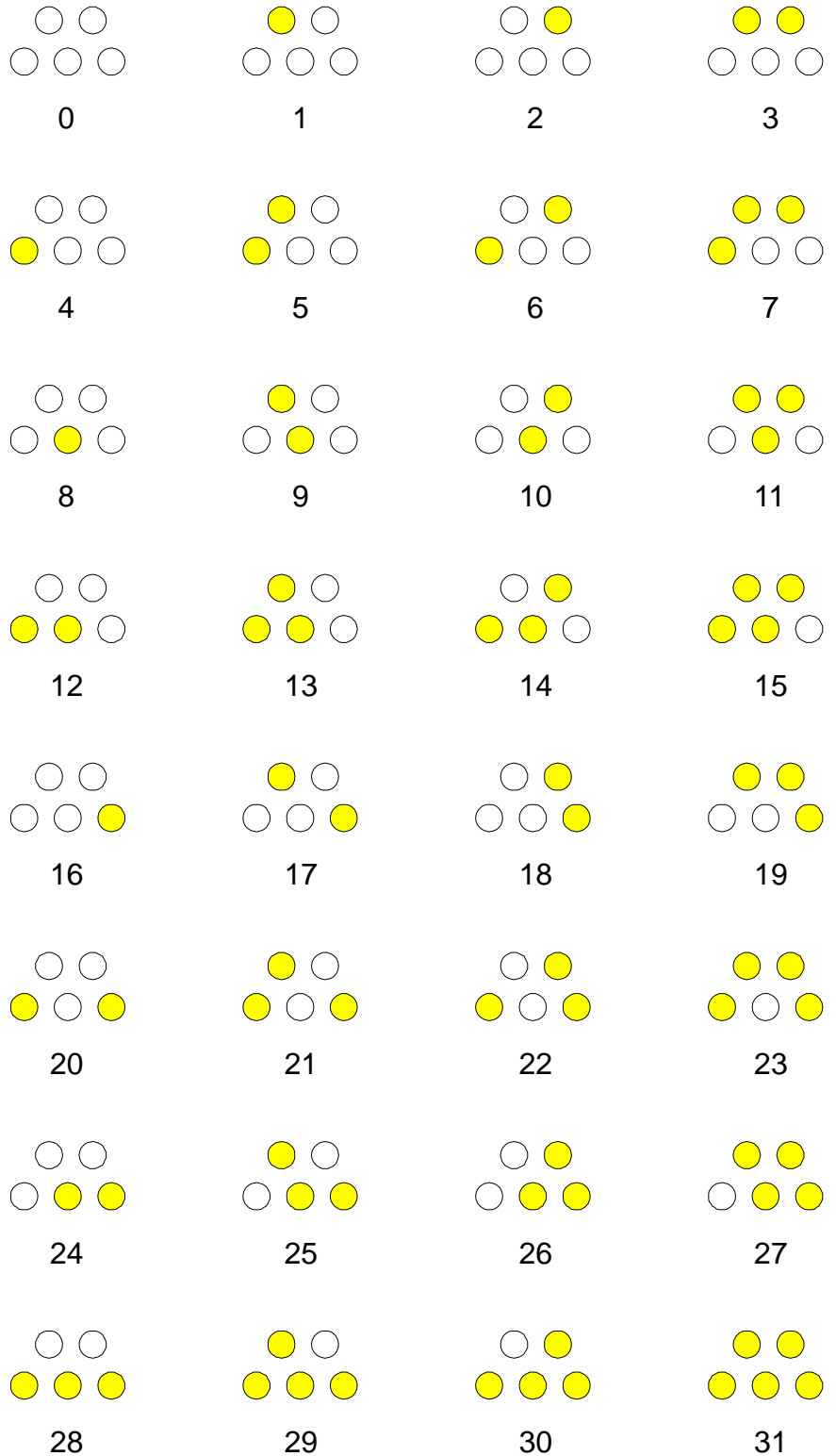

„Error“  
or  
„not detected“

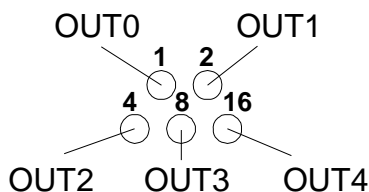
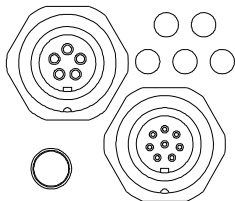



**Measuring Principle**
**Measuring principle:**

With the help of a super-bright red-light LED modulated light is aligned in parallel in the collimator optic unit. A suitable aperture technology ensures that three beams of red light ( $\varnothing$  3 mm each, 5 mm distance to each other) leave the transmitting branch of the transmitter, and at the receiving side are again directed onto three receiving optical-fibers by means of 3 apertures with suitable receiving optics.

By means of the optoelectronic detectors, the three light signals are converted into three electronic signals and are digitised by way of 12-bit-A/D-converters. When a spray jet now crosses the path of the three red light beams, the respective light beams are attenuated due to light absorption and/or light deflection at the droplets contained in the spray jet. The degree of attenuation of the respective signal is a measure for the droplet contraction at the place of the light beam.



**Parameterization**
**Parameterization under Windows® with software SI-JET-Scope:**

The following three measurands are picked up and monitored in the production process by the SI-JET2 spray jet monitoring system:

- Spray jet density (average of the 3 red light parts CH\_L, CH\_C, CH\_R)
- Symmetry 1 (the two outer channels are put into proportion to each other)
- Symmetry 2 (Symmetry 1 is put into proportion to the centre channel)

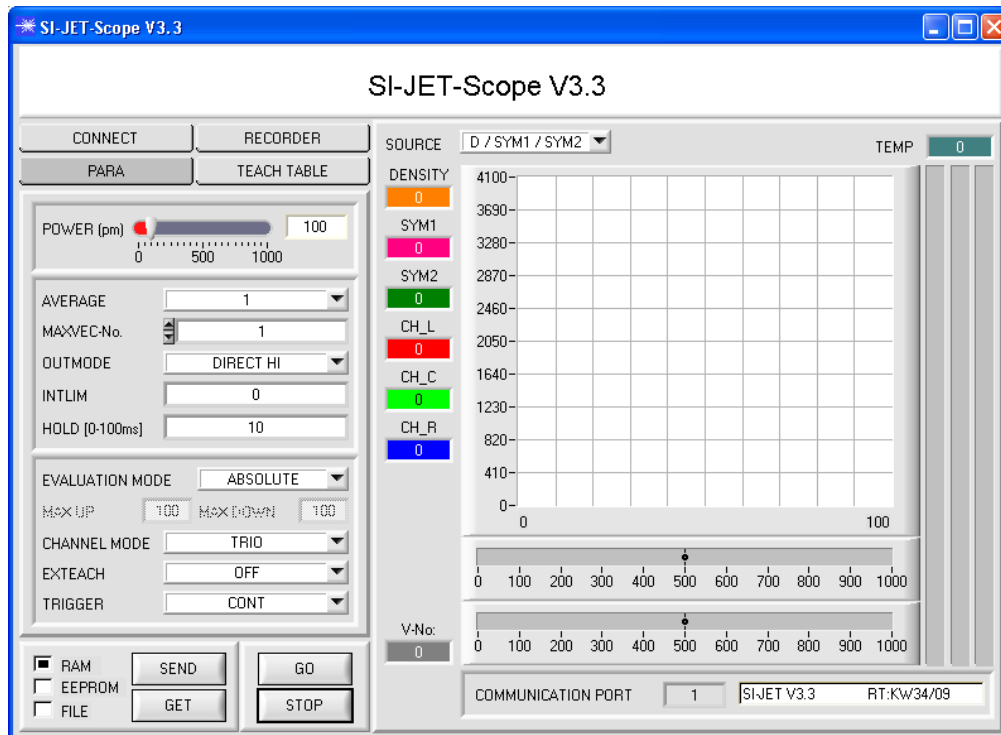
**Evaluation modes:**

The SI-JET can be operated with two different evaluation modes.

**ABSOLUTE:** The absolute status of the three channels CH\_L, CH\_C, and CH\_R is used for evaluation.

**RELATIVE:** The current status of the three channels CH\_L, CH\_C, and CH\_R relative to their maximum values in the last 60 seconds is used for evaluation.

**TEACH process:**

The teach process can be performed either with the parameterisation software, by way of the teach input (IN0 PIN3 green at the cab-las8/SPS cable), or by means of the switch at the housing. When teaching is performed through the IN0 input, the tolerance values for density and symmetry must first be stored once in the EEPROM of the control unit with the help of the parameterisation software. Before input IN0 is activated, the status to be taught must be present at the sensor front-end, i.e. spraying must first be switched on, and then IN0 must be set to +24V.

The current status is taught to as many rows in the Teach Table as have been selected under MAXVEC-No. Classification is performed by way of different set tolerances.



Data Recorder

**Function of the data recorder:**

The SI-JET-Scope software features a data recorder that makes it possible to save a certain number of data frames. The recorded file is saved to the hard disk of the PC and can then be evaluated with a spreadsheet program.

The created file has eight columns and as many rows as data frames were recorded. A row is structured as follows: Date and time, CH\_L, CH\_C, CH\_R, DENSITY, SYM1, SYM2, TEMP.

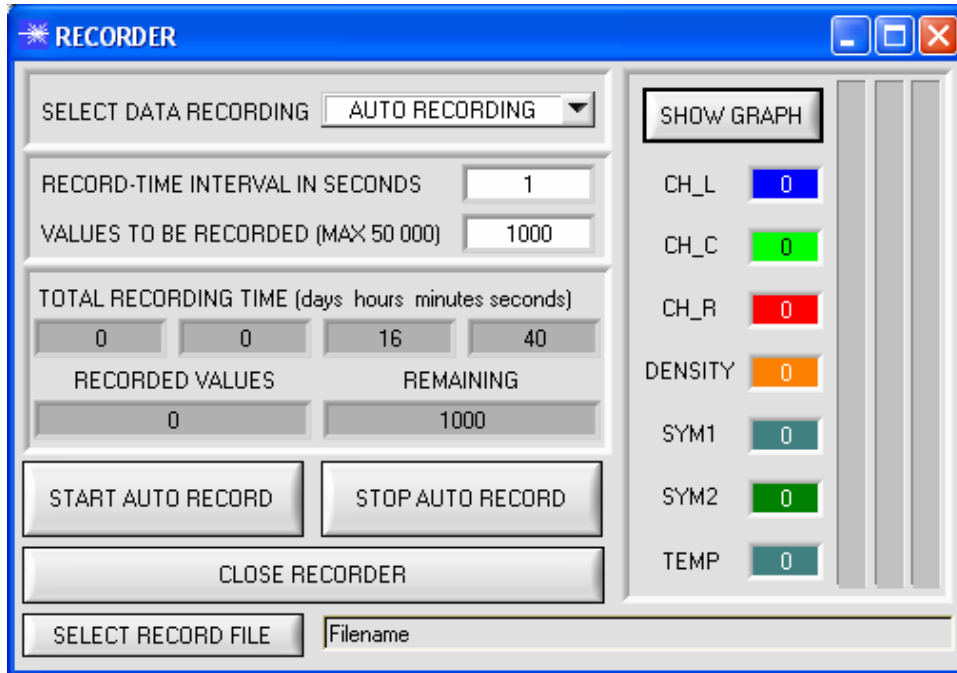



Accessories

**Blast air top part ABL-SI-JET3-d12**  
 suitable for  
 SI-JET3-d12-T (transmitter) and  
 SI-JET3-d12-R (receiver)  
 (please order blast air top parts separately)

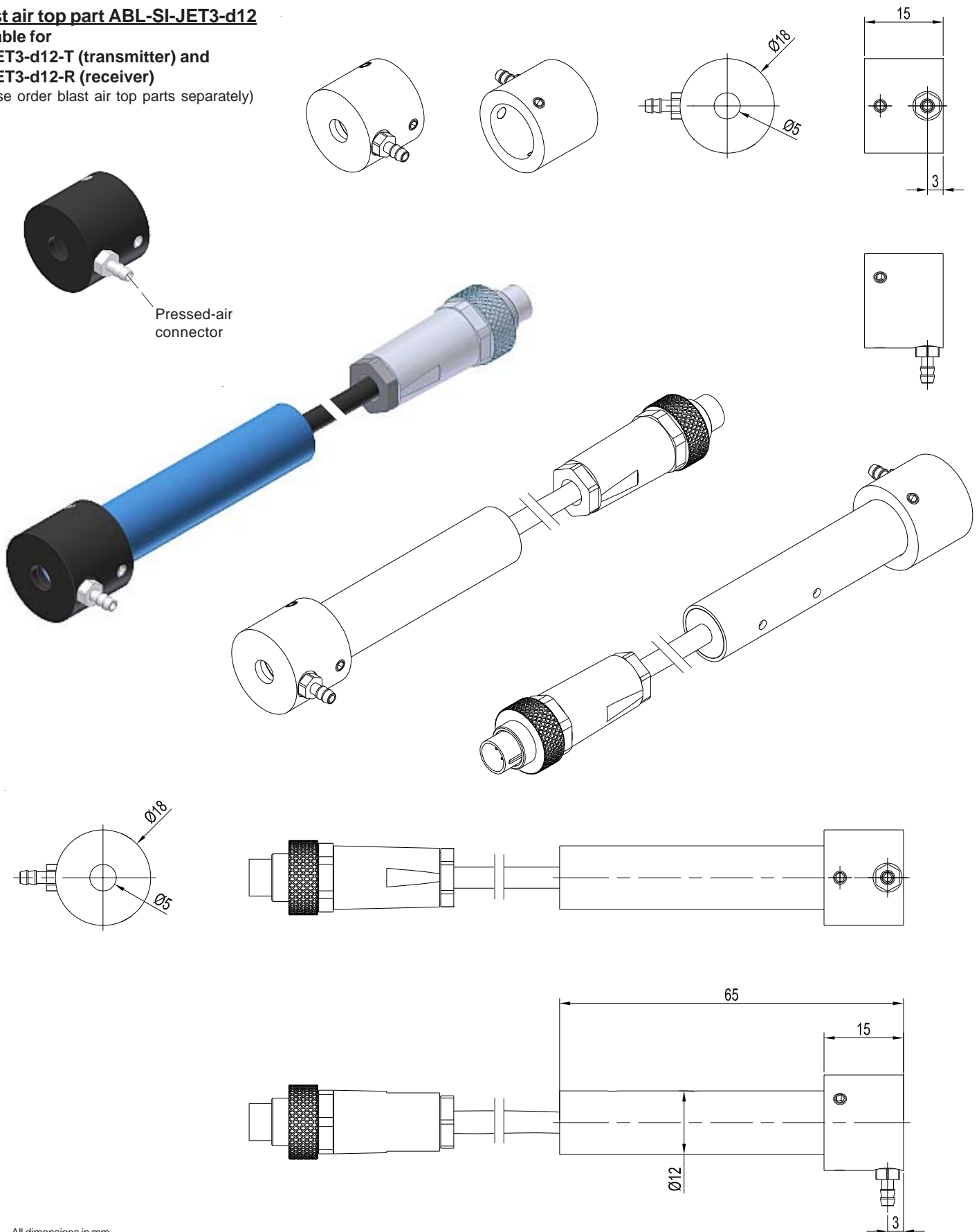

All dimensions in mm



## Application Example

### Spray jet monitoring in tile coating

Prior to thermal treatment pressed tile blanks are coated with a sealing layer that is applied as an aqueous solution by two spray nozzles. With an SI-JET3-CON5 control unit, a split SI-JET3-d12 frontend (incl. SI-JET-MUX 3-fold distributor boxes), and suitable blow-air attachment units ABL-SI-JET3-d12 two spray curtains are detected and monitored at the same time.

The distance between two nozzles is 240 mm, the opening angle is 110°. Because of the available space the distance between the SI-JET lines should be approx. 35-40 mm, and process conditions suggest a transmitter/receiver distance of about 900-1000 mm.

The nozzles frequently get choked by particles (glass powder, corundum powder), and tiles then are not completely coated. This means defective products that frequently are detected later by the customer, because dirt deposits will occur at such uncoated areas.

After the sensor was installed in the holder, incl. the blow-air attachment units that were sealed with Teflon tape, air flushing was activated, and the system was placed in the spray chamber.

The transmitter/receiver distance is about 1000 mm, i.e. each 400 mm away from the nozzles. The measurement effect between spray curtain on and off was (absolute) approx. 500 digits.

