

SI-JET Series

▶ SI-JET2-CON3 R3-M-A2.0-(2.5)-...-3X R3-M-A1.1-(1.5)-...-3X

By way of the three optical fibers, the SI-JET2 Spray Jet Monitoring System monitors the density and the symmetry around the opening angle of the spray jet. With the comprehensive SI-JET2-Scope software the system can be parameterised under Windows®.

- Telecentric design enables a big fork width
- Averaging (over 32000 values)
- RS232 interface and Windows® user interface
- Teachable by means of integrated button, PLC, or PC)
- Insensitive to outside light due to clocked red light LED (100 kHz)
- Insensitive to dirt accumulation due to pressed air facility (at transmitter and receiver side of the fork)
- High dynamic range (due to light power adjustment of LED via RS232)
- High resolution (12-bit-A/D-converter)
- Can be used in areas subject to explosion hazards  (EX-RL, Zone 0)

In Proud Partnership with Sensor Instruments

PAQUIN
SENSORS

For technical support, sales, & distribution
within the USA & Canada

www.paquin.com | (800) 831-8217 | paquinsensors@paquin.com

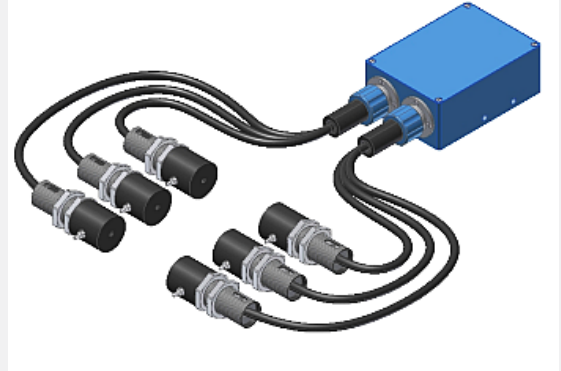

Design

Product name:

SI-JET2-CON3

(Electronic control unit, incl. Windows® PC software SI-JET-Scope)

R3-M-A2.0-(2.5)-5000-67°-3X

(Transmitter fiber optics)

R3-M-A1.1-(1.5)-5000-67°-3X

(Receiver fiber optics)

R3-M-A1.1-(1.5)-5000-67°-3X

(Receiver fiber optics incl. add-on aoptics KL-M18-A1.1 and blast-air top part ABL-M18-3)

Accessories: (p. 4)

- KL-M18-A2.0** Add-on optics transm.
- KL-M18-A1.1** Add-on optics receiv.
- ABL-M18-3** Blast-air top part

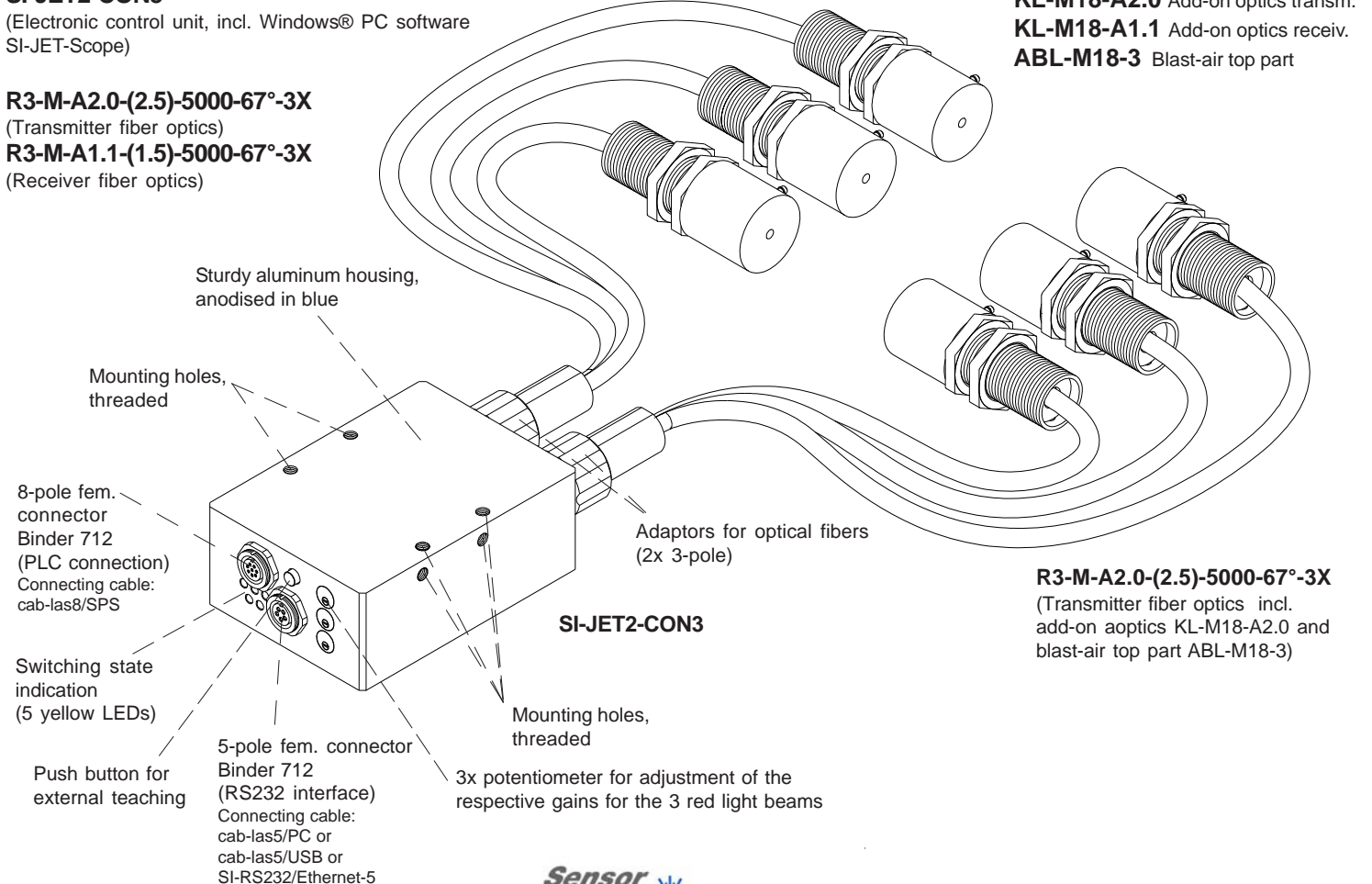



Technische Daten

Model	SI-JET2-CON3 (electronic control unit)
Voltage supply	+24VDC ($\pm 10\%$), reverse-polarity protected, overload protected
Current consumption	typ. 200 mA
Operating temperature	-10°C ... 50°C
Enclosure rating	IP64
Housing material	Aluminium, anodized in blue Fiber optics adaptor: Aluminium, anodized in black
Housing dimensions	Approx. 90 mm x 65 mm x 35 mm (without flange connectors or fiber optics adaptors)
Type of connector	Connection to PC: 5-pole female connector type Binder 712 Connection to PLC: 8-pole female connector type Binder 712
Type of transmitter	Super-bright LED (red, 650 nm), modulated 100 kHz
Fiber optics adaptor	Transmitter: 3-pole Receiver: 3-pole
Fiber optics	Transmitter fiber optics (3-fold): R3-M-A2.0-(2.5)-5000-67° (fiber optic bundle \varnothing 2.5 mm) Receiver fiber optics (3-fold): R3-M-A1.1-(1.5)-5000-67° (fiber optic bundle \varnothing 1.5 mm)
External teaching	By means of an integrated teach button or via input IN0
Switching state indication	By means of 4 yellow LEDs
Interface	RS232, parameterisable under Windows®
Averaging	Adjustable under Windows: max. 32768 values
Digital outputs (OUT0 ... OUT4)	0V/+U _B , short-circuit-proof, 100 mA max. switching current; npn/pnp able (bright-/dark-switching can be switched)
External input for teaching (IN0)	+U _B -Signal (min. pulse length 250 ms, max. pulse length 1000 ms)
Pulse lengthening	Adjustable under Windows®: 0 ms .. 100 ms
EMV test acc. to	DIN EN 60947-5-2 

Dimensions

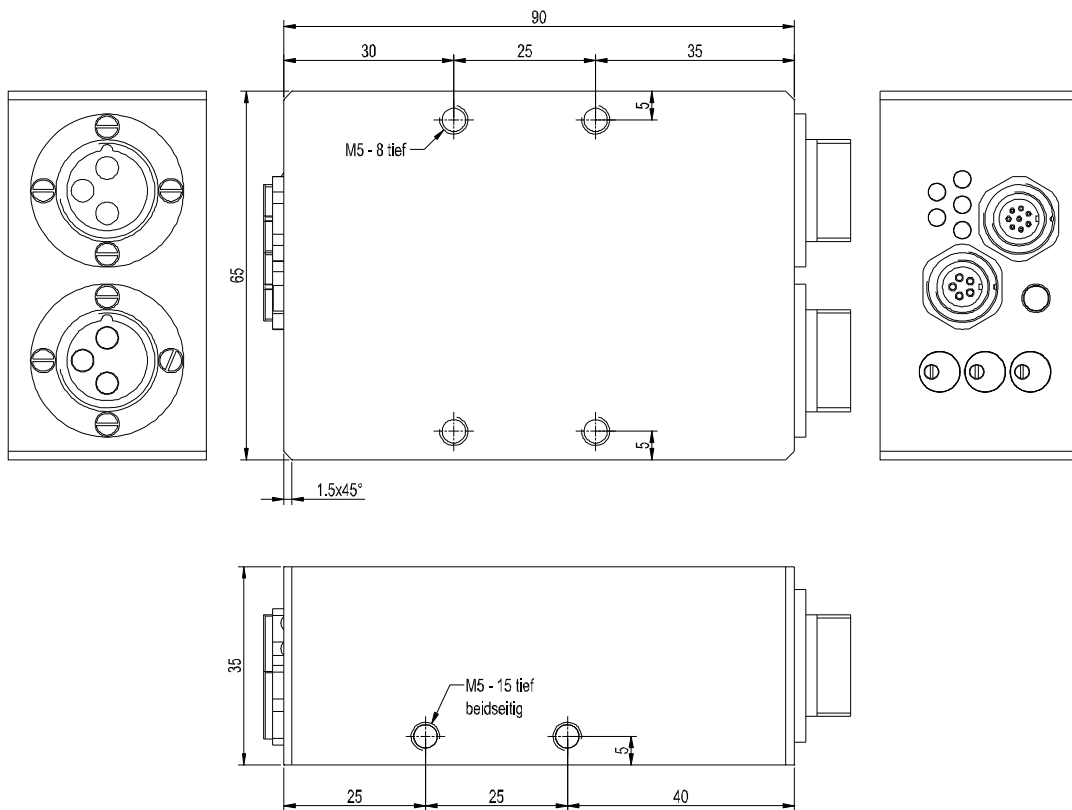
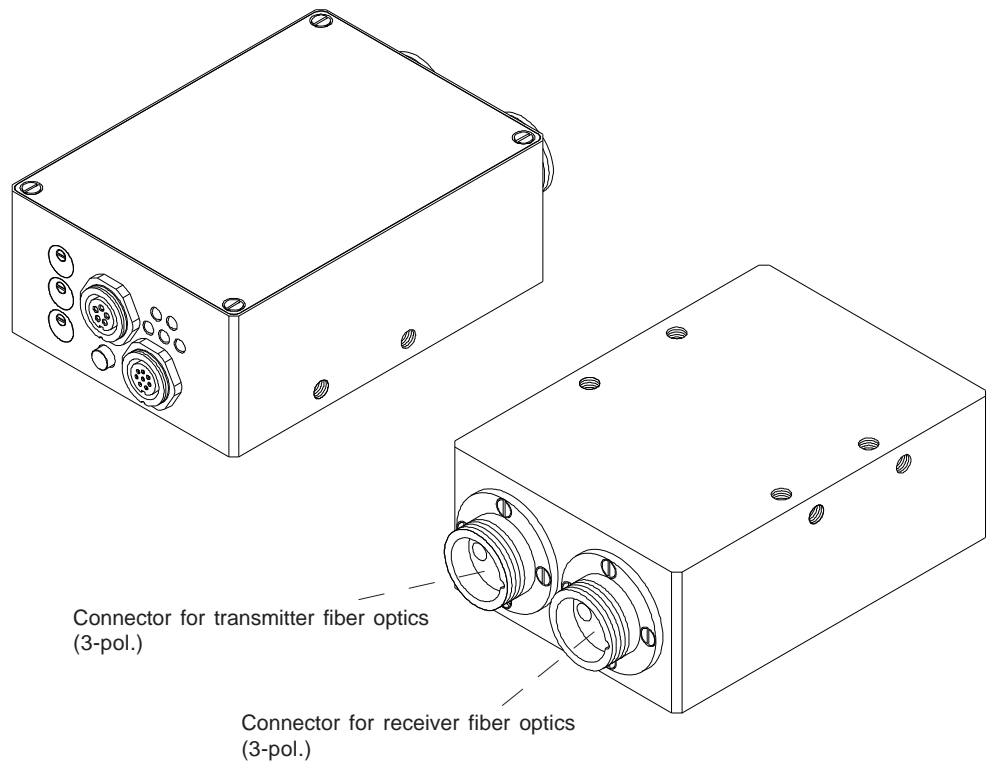
SI-JET2-CON3
(Electronic control unit)



All dimensions in mm



Fiber Optic Frontends

Transmitter fiber optics

R3-M-A2.0-(2.5)-5000-67°-3X

R3 = Reflected light operation, three-fold

M = Metal sheath

A2.0-(2.5) = Sensor head type A2.0 with fiber bundle Ø 2,5 mm

5000 = Total length of optical fiber 5000 mm

67° = Beam angle

Receiver fiber optics

R3-M-A1.1-(1.5)-5000-67°-3X

R3 = Reflected light operation, three-fold

M = Metal sheath

A1.1-(1.5) = Sensor head type A1.1 with fiber bundle Ø 1,5 mm

5000 = Total length of optical fiber 5000 mm

67° = Beam angle

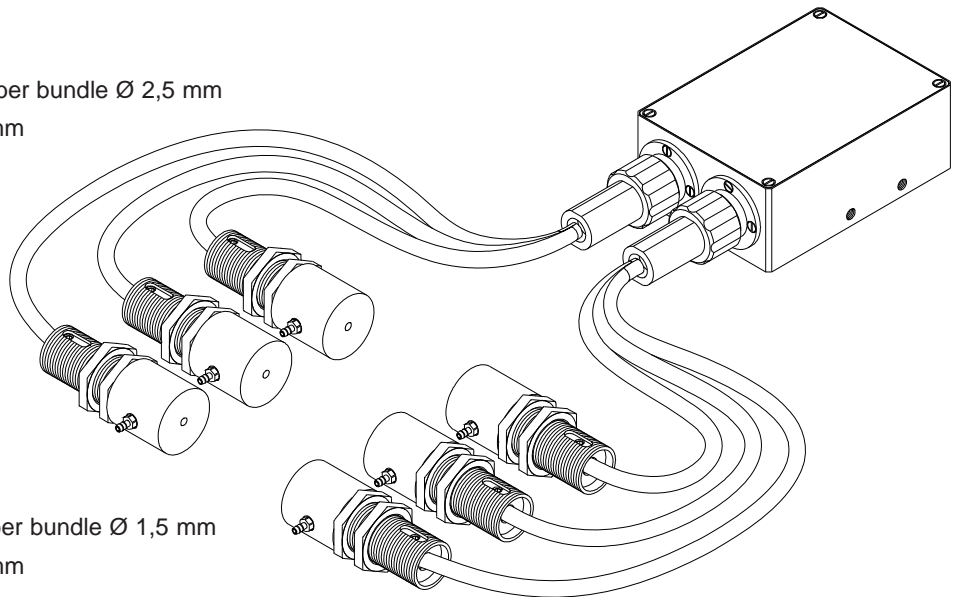

Accessories

Please order separately:

Add-on optics KL-M18-A2.0

(for use with transmitter fiber optics R3-M-A2.0-(2.5)-5000-67°-3X)

Add-on optics KL-M18-A1.1

(for use with receiver fiber optics R3-M-A1.1-(1.5)-5000-67°-3X)

- Big working distance (typ. 60 mm)
- Working range typ. 20 mm ... 65 mm
- Minimum change of color when distance changes
- Can be focused
- Scratch-resistant optics made of glass
- Sturdy housing made of brass (nickel-plated)

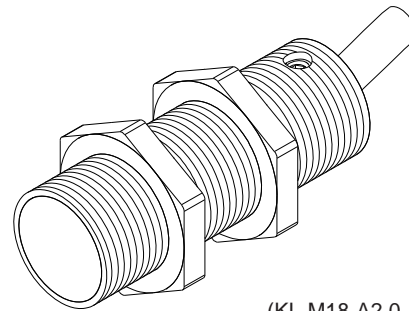

(KL-M18-A2.0 or KL-M18-A1.1, description cf. separate data sheet LWL Series)

For one SI-JET system 3 units of KL-M18-A2.0 and 3 units of KL-M18-A1.1 are necessary.

Please order separately:

Blast air top part ABL-M18-3

(for use with add-on optics KL-M18-A2.0 or KL-M18-A1.1)

Air exit opening Ø 3.0 mm

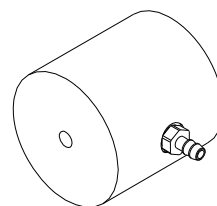

(ABL-M18-3, description cf. separate data sheet ABL-M18)

For one SI-JET system 6 units of ABL-M18-3 are necessary.



Dimensions

Add-on optics for fiber optic frontends
KL-M18-A1.1 or KL-M18-A2.0

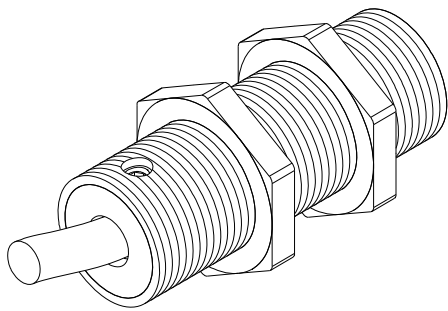
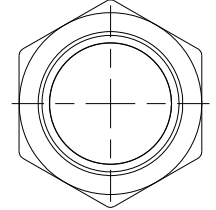
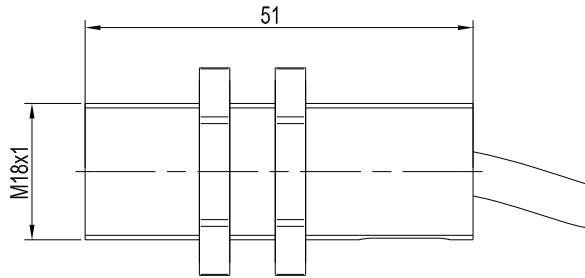
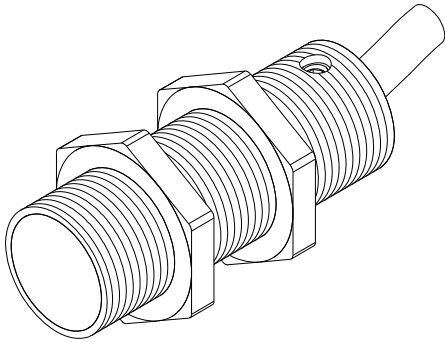

ABL-M18-3 mounted onto KL-M18-:

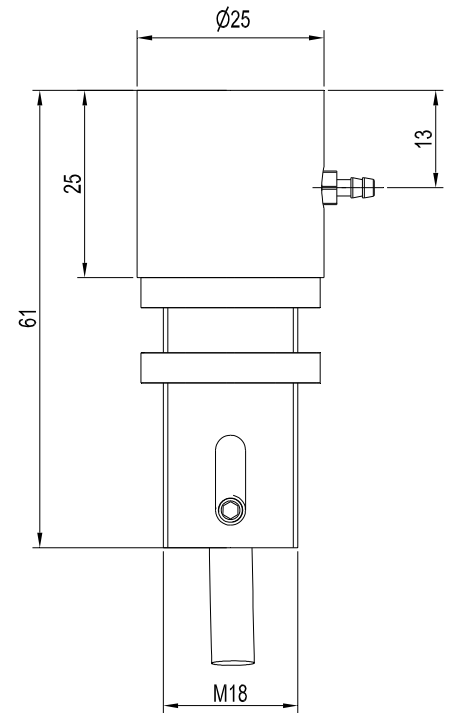

Blast air top part ABL-M18-3
(for fiber optic frontend KL-M18-...)

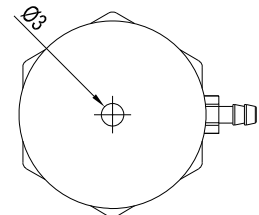
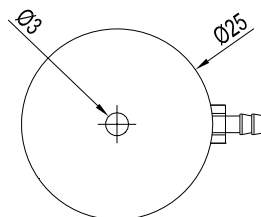
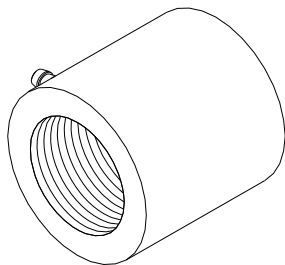
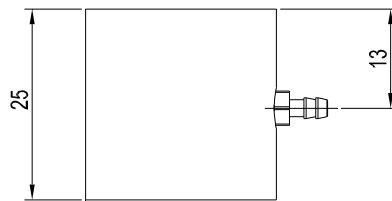
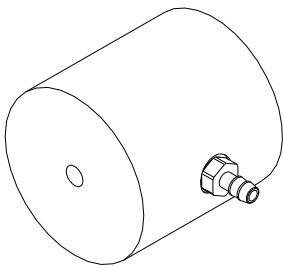

All dimensions in mm



Connector Assignment

**Connection SI-JET2-CON3 to PLC:
8-pole fem. connector Binder Series 712**

Pin:	Color:	Assignment:
1	white	GND (0V)
2	brown	+24VDC (±10%)
3	green	INO
4	yellow	OUT0
5	grey	OUT1
6	pink	OUT2
7	blue	OUT3
8	red	OUT4

Connecting cable:
cab-las8/SPS-(length)
cab-las8/SPS-w-(length) (angle type, 90°)
(standard length 2m)

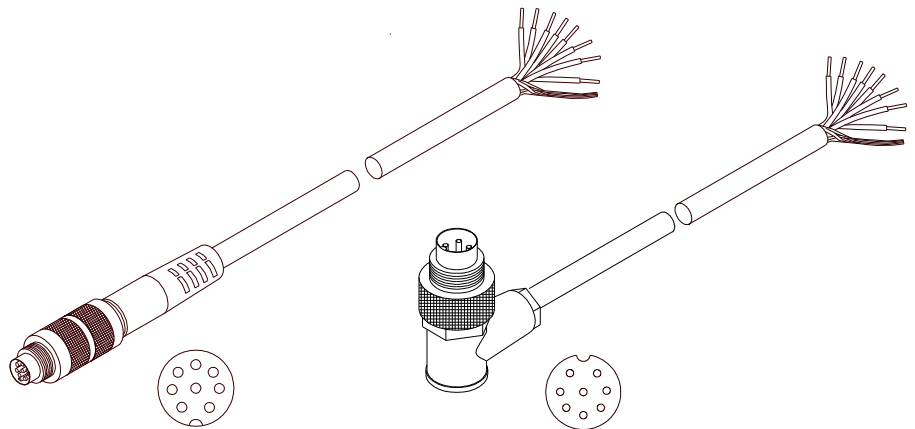

cab-las8/SPS-...
(max. length 25m, outer jacket: PUR)

cab-las8/SPS-w-...
(max. length 25m, outer jacket: PUR)

**Connection SI-JET2-CON3 to PC:
5-pole fem. connector Binder Series 712**

Pin:	Assignment:
1	GND (0V)
2	TxD
3	RxD
4	+24V (+Ub, OUT)
5	not connected

Connection via RS232 interface at the PC:
Connecting cable:
cab-las5/PC-(length)
cab-las5/PC-w-(length) (angle type 90°)
(standard length 2m)

alternative:
Connection via USB interface at the PC:
Connecting cable (incl. driver software):
cab-las5/USB-(length)
cab-las5/USB-w-(length) (angle type 90°)
(standard length 2m)

alternative:
Connection to local network via Ethernet bus:
Adapter (based on Lantronix XPortModul):
SI-RS232/Ethernet-5-(length)
(standard length 2m)

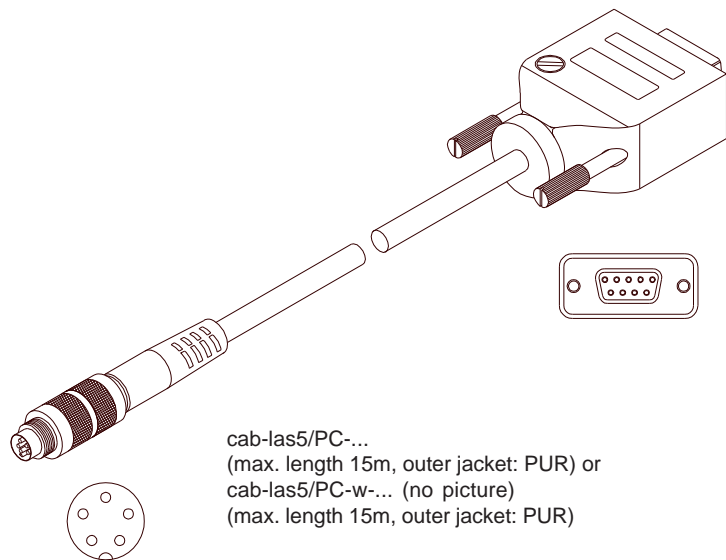

cab-las5/PC-...
(max. length 15m, outer jacket: PUR) or
cab-las5/PC-w-... (no picture)
(max. length 15m, outer jacket: PUR)

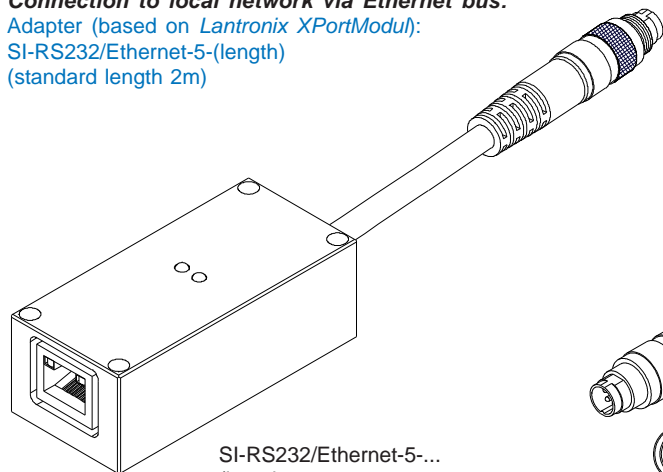

SI-RS232/Ethernet-5-...
(length 0,5m, 1m, or 2m,
outer jacket: PUR)

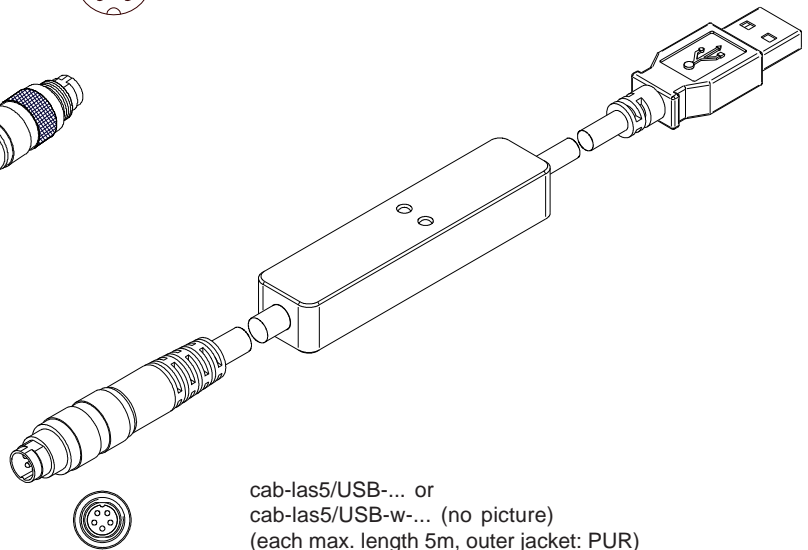

cab-las5/USB-... or
cab-las5/USB-w-... (no picture)
(each max. length 5m, outer jacket: PUR)



Settings

Potentiometer for adjustment of gain:

Rotation clockwise: Increase of signal

Adjustment of gain for red light beam
of CH_R (right)

Adjustment of gain for red light beam
of CH_C (centre)

Adjustment of gain for red light beam
of CH_L (left)

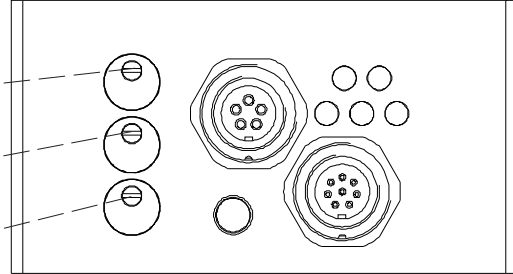



Measuring Principle

With the help of a super-bright red-light LED modulated light is coupled in a transmitting optical-fiber and is aligned in parallel by means of a collimator optic unit. A suitable aperture technology ensures that three beams of red light (\varnothing 3 mm each) leave the transmitting branch of the transmitter, and at the receiving side are again directed onto three receiving optical-fibers by means of 3 apertures with suitable receiving optics.

By means of the optoelectronic detectors that are integrated in the receiving optical-fiber holder, the three light signals are converted into three electronic signals and are digitised by way of 12-bit-A/D-converters. When a spray jet now crosses the path of the three red light beams, the respective light beams are attenuated due to light absorption and/or light deflection at the droplets contained in the spray jet. The degree of attenuation of the respective signal is a measure for the droplet concentration at the place of the light beam.



Parameterization
Parameterization under Windows® with software SI-JET-Scope:

The following three measurands are picked up and monitored in the production process by the SI-JET2 spray jet monitoring system:

- Spray jet density (hereinafter referred to as density).
- Symmetry 1 (the two outer channels are put into proportion to each other).
- Symmetry 2 (Symmetry 1 is put into proportion to the centre channel).

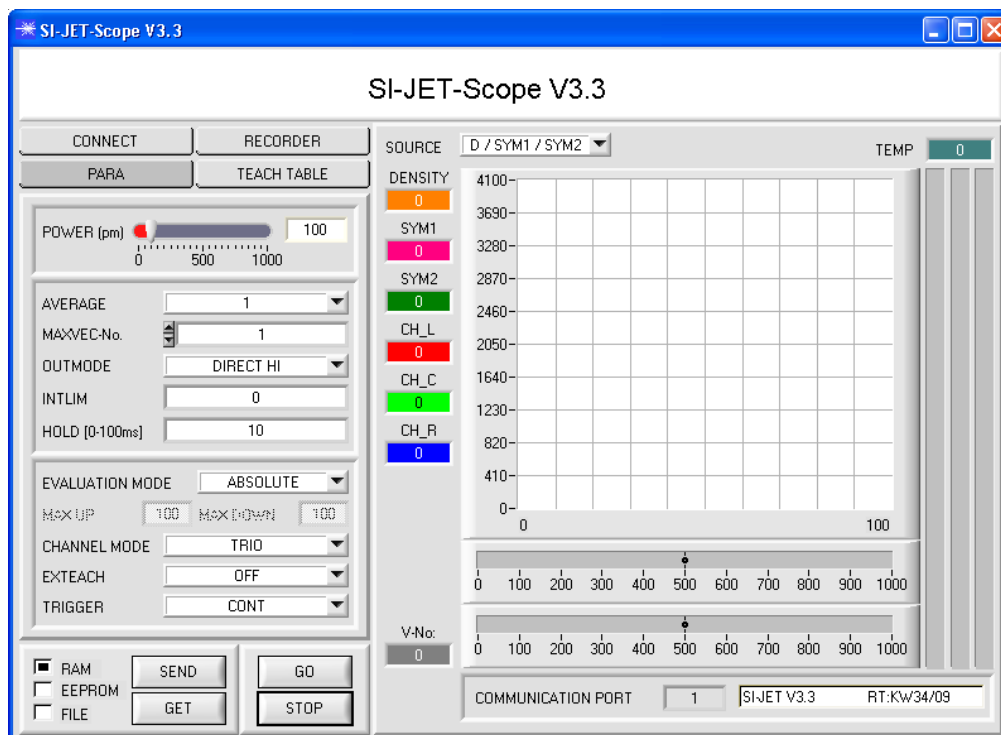
Evaluation modes:

The SI-JET2 can be operated with two different evaluation modes.

ABSOLUTE: The absolute status of the three channels CH_L, CH_C, and CH_R is used for evaluation.

RELATIVE: The current status of the three channels CH_L, CH_C, and CH_R relative to their maximum values in the last 60 seconds is used for evaluation.

TEACH process:

The teach process can be performed either with the parameterisation software, by way of the teach input (IN0 PIN3 green at the cab-las8/SPS cable), or by means of the switch at the housing. When teaching is performed through the IN0 input, the tolerance values for density and symmetry must first be stored once in the EEPROM of the control unit with the help of the parameterisation software. Before input IN0 is activated, the status to be taught must be present at the sensor front-end, i.e. spraying must first be switched on, and then IN0 must be set to +24V.

The current status is taught to as many rows in the Teach Table as have been selected under MAXVEC-No. Classification is performed by way of different set tolerances.



LED-Display

LED-Display:

Mit Hilfe von 5 gelben LEDs wird der erkannte Zeilenvektor am Gehäuse des SI-JET2 Sensors visualisiert. Der am LED-Display angezeigte Zeilenvektor wird im BINARY Modus (OUT BINARY) gleichzeitig als 5-Bit-Binär-Information an den Digitalausgängen OUT0 ... OUT4 der 8-pol. SI-JET2/SPS-Anschlussbuchse ausgegeben.

Der SI-JET2 Sensor kann maximal 31 Zeilenvektoren (0 ... 30) entsprechend der einzelnen Zeilen in der TEACH TABLE verarbeiten. Ein "Fehler" bzw. ein "nicht erkannter Zeilenvektor" wird durch das Aufleuchten aller LEDs angezeigt (OUT0 ... OUT4 Digitalausgänge sind auf HIGH Pegel).

Im DIRECT Modus (OUT DIRECT HI bzw. OUT DIRECT LO) sind maximal 5 Zeilenvektoren (Nr. 0, 1, 2, 3, 4) erlaubt.

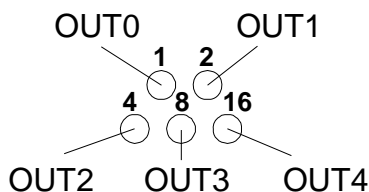
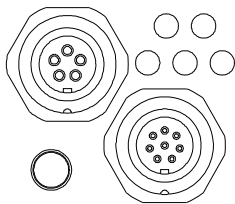

0	1	2	3
4	5	6	7
8	9	10	11
12	13	14	15
16	17	18	19
20	21	22	23
24	25	26	27
28	29	30	31

„Fehler“
bzw.
„nicht erkannt“



Datenrekorder

Funktion des Datenrekorders:

Die SI-JET2-Scope Software beinhaltet einen Datenrekorder, der es erlaubt eine gewisse Anzahl von Datenframes abzuspeichern. Das aufgezeichnete File wird auf der Festplatte Ihres PC abgespeichert und kann anschließend mit einem Tabellenkalkulationsprogramm ausgewertet werden.

Das erzeugte File hat acht Spalten und so viele Zeilen, wie Datenframes aufgezeichnet worden sind. Eine Zeile ist wie folgt aufgebaut: Datum und Uhrzeit, CH_L, CH_C, CH_R, DENSITY, SYM1, SYM2, TEMP.

