

In Proud Partnership with Sensor Instruments

**PAQUIN**  
SENSORS

For technical support, sales, & distribution  
within the USA & Canada

www.paquin.com | (800) 831-8217 | paquinsensors@paquin.com

# RLS Series

## ▶ RLS-MD-2-FIO Mark Detection

- Insensitive to outside light due to clocked white light
- 2 reflected light fiber optics (fiber cross-section 6 mm x 1 mm)
- Storing of up to 31 norm vectors
- Tolerance adjustable for each norm vector
- Working distance typ. 10 mm ± 10%
- Parameterisable under Windows® (via Standard Mode)
- RS232 interface (USB or Ethernet converter is available)
- 5 switching outputs (npn-/pnp-able, 100 mA, short-circuit proof)
- Switching state indication by means of 5 yellow LEDs
- Transmitter power adjustable or controllable (STAT or DYN)
- Averaging can be activated (over up to approx. 32000 values)
- Scratch-resistance glass cover of optics
- Sturdy aluminum housing
- Analog output (0...+10V and 4...20mA, proportional to the gloss degree 0%...100% or via zoom function, up to tenfold zoom)

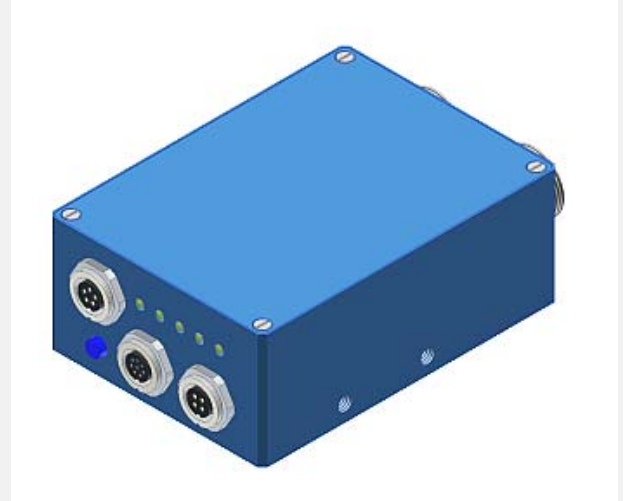

### Design

#### Product name:

#### RLS-MD-2-FIO

(incl. Windows® PC software RLS-GD-Scope)

#### Accessories: (cf. page 8)

#### Optical fiber

**R-S-R2.1-(6x1)-1200-67°**  
(Reflected light fiber optics)

4-pole fem. connector  
Binder Series 712  
(additional connection  
to PLC)  
Connecting cable:  
cab-las4/SPS

LED display:  
Switching state indication  
by means of 5 yellow  
LEDs

8-pole fem. connector  
Binder Series 712  
(connection to PLC)  
Connecting cable:  
cab-las8/SPS

TEACH button  
(input IN0)

5-pole fem. connector  
Binder Series 712  
(RS232 interface)  
Connecting cable:  
cab-las5/PC or  
cab-5/USB or  
cab-5/ETH

Sturdy aluminium  
housing, anodized  
in blue

Adapters for  
fiber optic cables

Mounting holes





Technical Data

Model	RLS-MD-2-FIO
Light source	2x reflected light fiber optic cables (e.g. type R-S-R2.1-(6x1)-1200-67°)
Working distance	typ. 10 mm ± 10%
Size of light sport	depends on the fiber optic cable that is used
Resolution	0.1 GU (Gloss Unit)
Reproducibility	± 0.1 GU (Gloss Unit), in case of an averaging of 512
Voltage supply	+24VDC (± 10%), protected against polarity reversal, overload protected
Aternating light operation	30 kHz
Ambient light	up to 5000 Lux
Enclosure rating	IP54
Current consumption	typ. 110 mA
Interface	RS232, parameterisable under Windows®
EMC test acc. to	DIN EN 60947-5-2
Type of connector	Connection to PLC: 8-pole circular female connector Binder Series 712 Connection to PLC: 4-pole circular female connector Binder Series 712 Connection to PC: 5-pole circular female connector Binder Series 712
Connecting cables	to PLC: cab-las8/SPS or cab-las8/SPS-w and cab-las4/SPS to PC/RS232 interface: cab-las5/PC or cab-las5/PC-w to PC/USB interface: cab-5/USB or cab-5/USB-w to PC/Ethernet interface: cab-5/ETH-500
Operating temperature range	-20°C ... +55°C
Storage temperature range	-20°C ... +85°C
Housing material	Aluminium, anodized in blue
Housing dimensions	LxWxH approx. 90 mm x 65 mm x 35 mm
Max. switching current	100 mA, short-circuit proof
Switching frequency	max. 5 kHz (depends on averaging)
Output DIGITAL (5x)	OUT0 ... OUT4: Qinv or Q, adjustable under Windows®: Qinv: npn bright-switching (npn normally closed) / pnp dark-switching (pnp normally open) Q: pnp bright-switching (pnp normally closed) / npn dark-switching (normally open)
Output ANALOG (2x)	1x voltage output 0 ... +10V 1x current output 4 ... 20mA
Input DIGITAL (1x)	IN0 (Pin 3), digital (0V/+24V) or teach push button at the housing
Sensitivity (switching threshold)	parameterisable under Windows® (either threshold or tolerance window to be chosen)
Pulse lengthening	0 ms ... 100 ms
Transmitter light power	adjustable under Windows®
Averaging	up to 32000 (adjustabe under Windows®)
Switching state indication	by means of 5 yellow LED

Dimensions

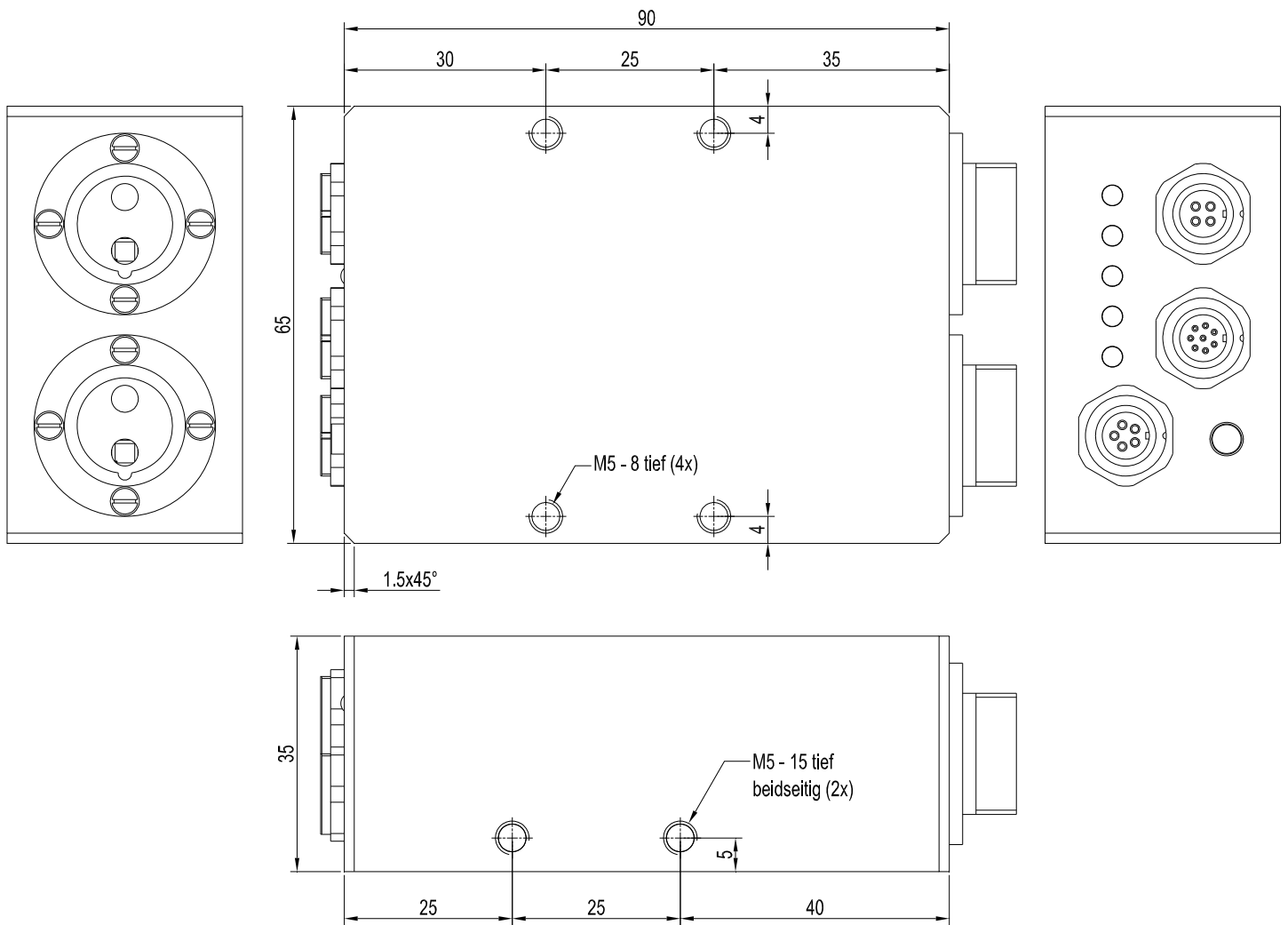

All dimensions in mm



**Connector Assignment**

**Connection to PLC:  
8-pole fem. connector Binder Series 712**

Pin:	Color:	Assignment:
1	white	GND (0V)
2	brown	+24VDC (±10%)
3	green	IN0
4	yellow	OUT0
5	grey	OUT1
6	pink	OUT2
7	blue	OUT3
8	red	OUT4

Connecting cable:  
cab-las8/SPS-(length)  
cab-las8/SPS-w-(length) (angle type, 90°)  
(standard length 2m)

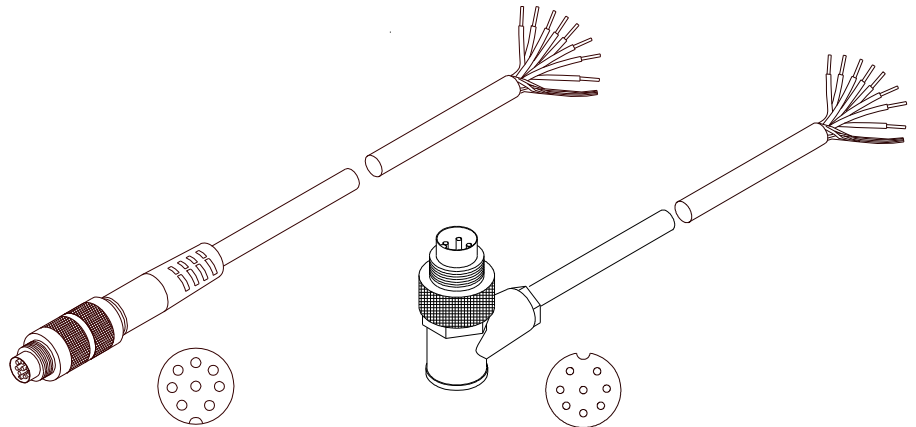

cab-las8/SPS-...  
(max. length 25m, outer jacket: PUR)

cab-las8/SPS-w-...  
(max. length 25m, outer jacket: PUR)

**Additional connection to PLC:  
4-pole fem. connector Binder Series 712**

Pin:	Color:	Assignment:
1	white	GND (0V)
2	brown	not connected
3	black	Analog output voltage (0...+10V)
4	blue	Analog output current (4...20mA)

Connecting cable:  
cab-las4/SPS-(length)  
(Standard length 2m)

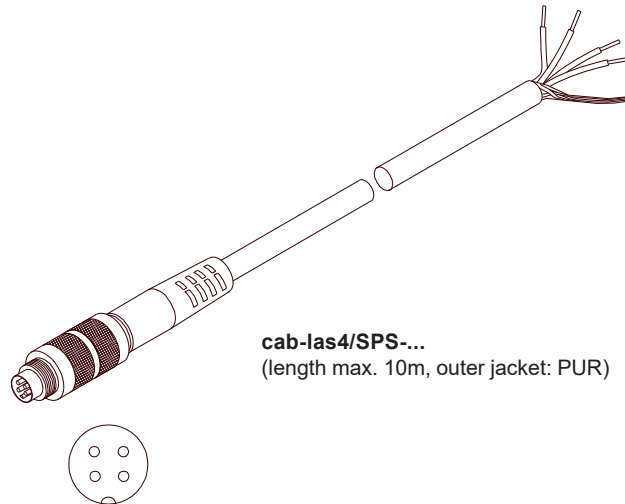

cab-las4/SPS-...  
(length max. 10m, outer jacket: PUR)



**Connector Assignment**

**Connection to PC:  
5-pole fem. connector Binder Series 712**

Pin:	Assignment:
1	GND (0V)
2	TxD
3	RxD
4	+24VDC (+Ub, OUT)
5	not connected

**Connection via RS232 interface at the PC:**

Connecting cable:  
 cab-las5/PC-(length)  
 cab-las5/PC-w-(length) (angle type 90°)  
 (standard length 2m)

**alternative:**

**Connection via USB interface at the PC:**

USB converter (incl. driver software):  
 cab-5/USB-(length)  
 cab-5/USB-w-(length) (angle type 90°)  
 (standard length 2m)

**Connection to local network via Ethernet bus:**

Ethernet converter (incl. software „SensorFinder“):  
 cab-5/ETH-500  
 (standard length 0.5m)

Optional: External CAT5 cable, e.g.  
 cab-eth/M12D-RJ45-flx-(length)

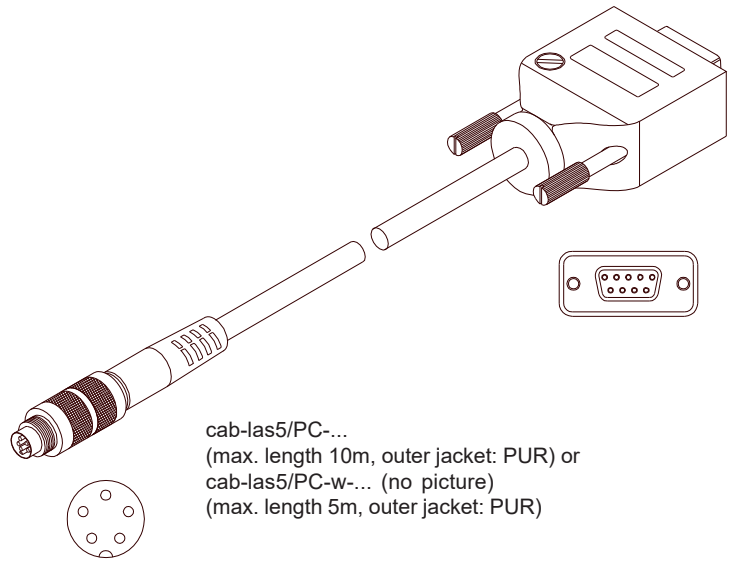

cab-las5/PC-...  
 (max. length 10m, outer jacket: PUR) or  
 cab-las5/PC-w-... (no picture)  
 (max. length 5m, outer jacket: PUR)

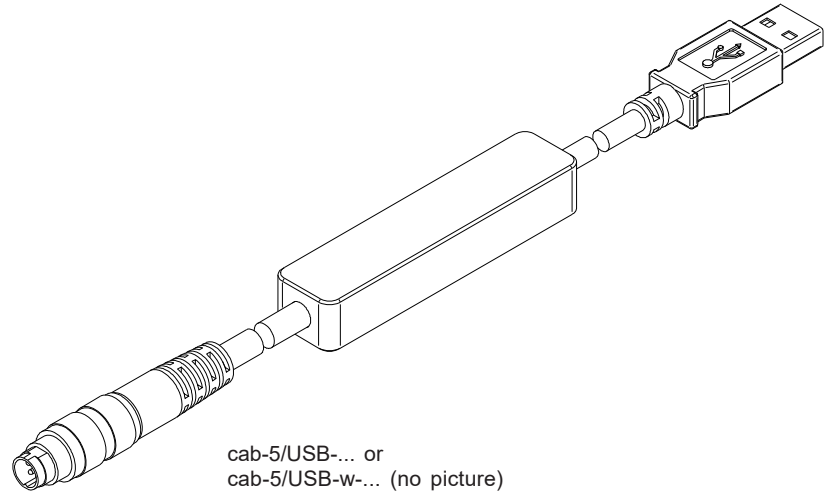

cab-5/USB-... or  
 cab-5/USB-w-... (no picture)  
 (each max. length 5m, outer jacket: PUR)

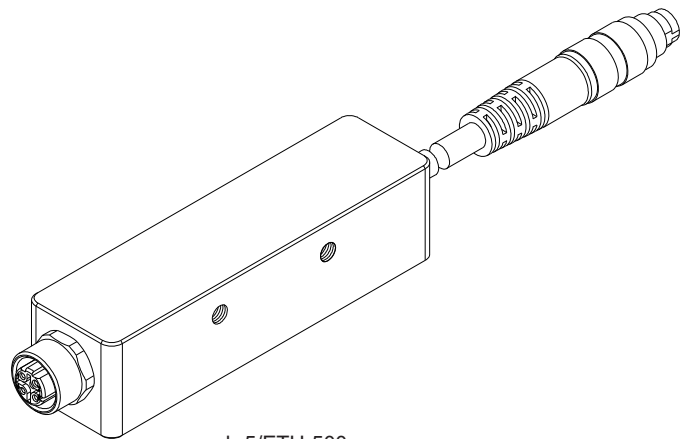

cab-5/ETH-500  
 (length 0.5m, outer jacket: PUR)  
 4-pole M12 fem. conn. (D-coded)  
 for connection of an external  
 CAT5 cable, e.g.  
 cab-eth/M12D-RJ45-flx-(length)



LED Display

**LED display:**

The gloss grade is visualized by means of 5 yellow LEDs at the housing of the gloss sensor. At the same time the gloss grade indicated at the LED display is output as 5-bit binary information at the digital outputs OUT0 ... OUT4 of the 8-pole PLC connector.

In the DIRECT mode the maximum number of gloss grades to be taught is 5. These 5 gloss grades can be directly output at the 5 digital outputs. The respective detected gloss grade is displayed by means of the 5 yellow LEDs at the gloss sensor housing.

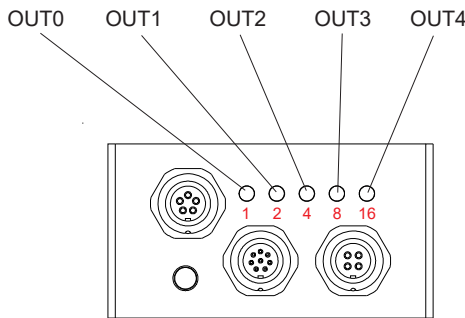

○ ○ ○ ○ ○ 0	● ○ ○ ○ ○ 1	○ ● ○ ○ ○ 2
● ● ○ ○ ○ 3	○ ○ ● ○ ○ 4	● ○ ● ○ ○ 5
○ ● ● ○ ○ 6	● ● ● ○ ○ 7	○ ○ ○ ● ○ 8
● ○ ○ ● ○ 9	○ ● ○ ● ○ 10	● ● ○ ● ○ 11
○ ○ ● ● ○ 12	● ○ ● ● ○ 13	○ ● ● ● ○ 14
● ● ● ● ○ 15	○ ○ ○ ○ ● 16	● ○ ○ ○ ● 17
○ ● ○ ○ ● 18	● ● ○ ○ ● 19	○ ○ ● ○ ● 20
● ○ ● ○ ● 21	○ ● ● ○ ● 22	● ● ● ○ ● 23
○ ○ ○ ● ● 24	● ○ ○ ● ● 25	○ ● ○ ● ● 26
● ● ○ ○ ● 27	○ ○ ● ● ● 28	● ○ ● ● ● 29
○ ● ● ● ● 30	● ● ● ● ● „error“ respectively „not detected“	



**Parameterization**

**Windows® user interface:**

The RLS-MD sensor is parameterized under Windows® with the RLS-GD-Scope software. The Windows® user interface facilitates the teach-in process at the sensor and supports the operator in the task of adjustment and commissioning of the sensor.

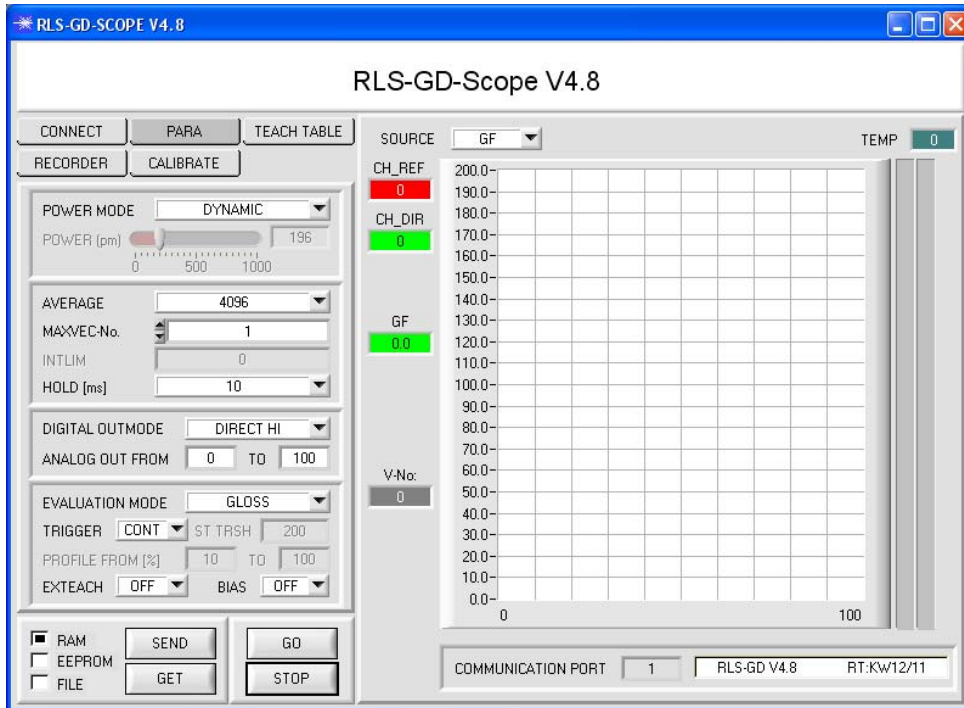

The RS232 interface (PARA) is used for setting parameters such as:

- MAXVEC-No.:  
Number of gloss degrees (normalized vectors) to be checked
- POWER MODE:  
In this function field the operating mode of automatic power correction at the transmitter unit can be set
- EVALUATION MODE:  
The RLS-GD sensor can be operated with two different evaluation modes (NORM\_INT or GLOSS)
- AVERAGE:  
Averaging over a maximum of 32768 values
- TRIGGER:  
Continuous or external or self trigger
- DIGITAL OUTMODE:  
Triggering of the digital outputs
- INTLIM:  
Minimum intensity required for gloss evaluation
- HOLD:  
Pulse lengthening up to 100ms max.

Under Windows® representation of the gloss value on a PC in numeric form and in a color chart, and representation of RGB values in a time chart. In addition the current RGB values are displayed as a bar chart.

**Firmware Update by means of the software Program Loader:**

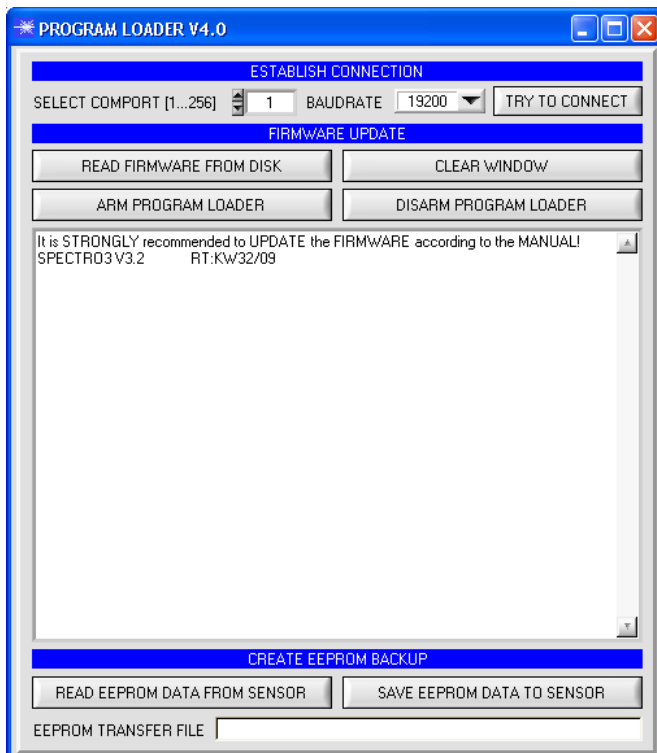

The software „Program Loader“ allows the user to perform an automatic firmware update. The update will be carried out through the RS232 interface.

An initialisation file (xxx.ini) and a firmware file (xxx.elf.S) are required for performing a firmware update. These files can be obtained from your supplier. In some cases an additional firmware file for the program memory (xxx.elf.p.S) is also needed, and this file will be automatically provided together with the other two files.

A plausibility check is performed after the initialisation file has been loaded with the Program Loader. If the initialisation file was changed or damaged, it will not be possible to perform a firmware update.

When the plausibility check is successfully completed, the instructions contained in the initialisation file will be carried out step by step.

The complete memory contents of the micro-controller in the sensor will be deleted in a firmware update. This means that both the program in the program memory and the data in the data memory will be lost.

The new firmware automatically writes the correct data to the program memory again.

However, the parameter settings, temperature curves, linearization curves, etc. that are stored in the data memory (EEPROM) will be deleted.

With the Program Loader V4.0 software the data will be saved in the EEPROM, and can be written back again after successful firmware update. For this purpose the software creates an EEPROM backup file.

**Optical Fibers**

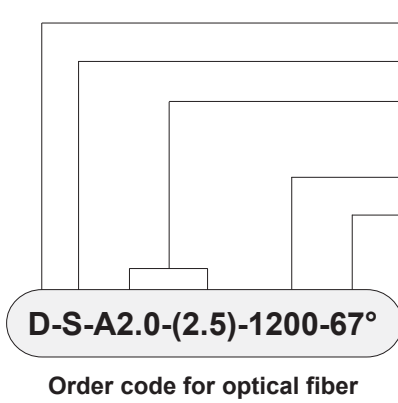

- ① **Operating mode** (e.g. D = transmitted light operation)
- ② **Sheathing type** (e.g. S = silicone-metal sheathing)
- ③ **Sensor type** (e.g. A2.0 = sensor type A, variant 2.0)  
(in brackets: **size of fiber bundle or fiber gap**, e.g. Ø 2.5 mm)
- ④ **Total length of optical fiber** (e.g. 1200 mm)
- ⑤ **Beam angle** (e.g. standard fiber 67°)

(Please cf. catalog „FIO Series“ - „formerly LWL Series“ - for detailed information on the various optical fibers available)

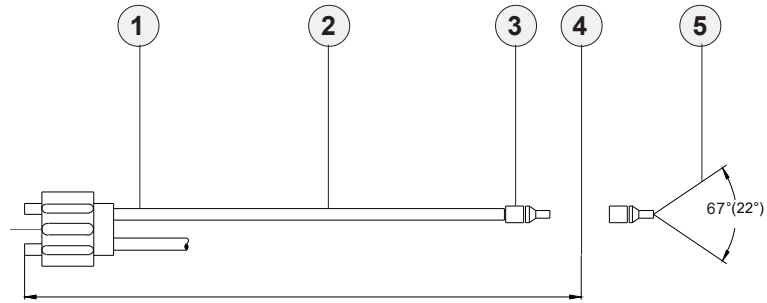

**Dimensions of adaptor**

**Attachment optics** (e.g. focus lenses)

**Overview: Optical fibers with reflected light operation**

**Overview: Optical fibers with transmitted light operation**

**Important information on mounting of optical fibers**

- cf. catalog FIO Series
- cf. catalog FIO Series
- cf. catalog FIO Series
- cf. catalog FIO Series
- cf. catalog FIO Series

**R-S-R2.1-(6x1)-1200-67°**

**R-S-R2.1-(6x1)-1200-22°**

Reflected light operation (R)

Silicone metal sheath (S)

**Sensor head type R2.1 (fiber cross-section 6 mm x 1 mm)**

Total length 1200 mm

Beam opening angle either 67° or 22°

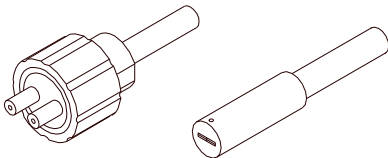





## Application Example

### Detection of a mark on foam foil webs

Line markings at different backgrounds should be detected without changing the settings of the sensor.

A suitable sensor for this application is the mark detection sensor RLS-MD-2-LWL which has two fiber optic connectors, two white light sources, and two receivers.

The evaluation mode „STANDARD“ of the software RLD-GD-Scope is to be used in this case.

The two fiber optic sensor heads (reflected light fiber optic cables, with cross-section 6 mm x 1 mm and beam opening angle 67°) are for instance arranged at a distance of 10 mm to the object surface, and the distance between the two fiber optic sensor heads is e.g. 20 mm.

By means of the software RLS-GD-Scope the sensor parameter POWER „DYN“ is chosen and an appropriate tolerance window is set. If a line marking lies below one of the two fiber optic sensor heads, this will result in a change of the switching state at the sensor output, as the preset tolerance range has been left.

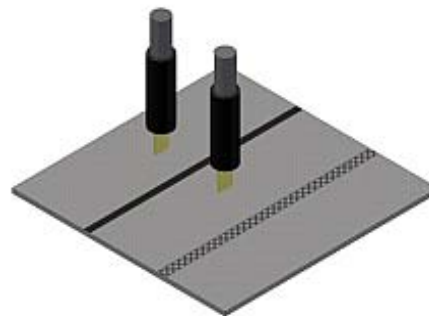
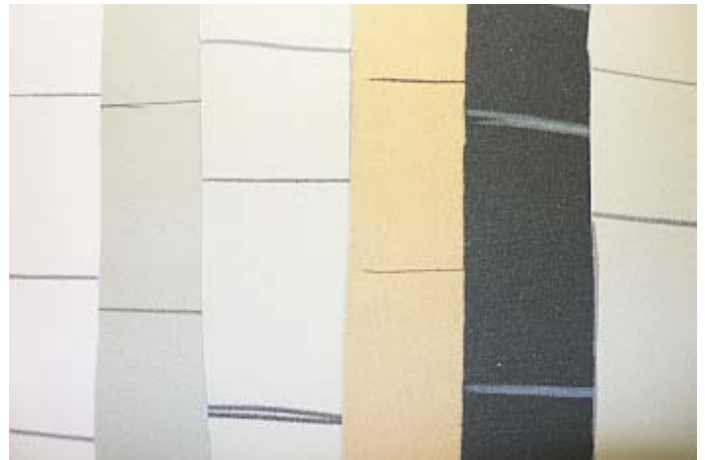

Arrangement of the fiber optic sensor heads for the application example above.