



Product info sheet no. C 4.8
Humidity/temperature sensors

With „ATEX“ licence for locations with explosive gas atmosphere and for locations with inflammable dust for use in atmospheric conditions

Technical data

Output 1: relative humidity

Output range 1: 0...100%rh
 Output signal 1:..... 4...20 mA
 Accuracy (MR 5...95%rh at 10...40 °C) ±2%rh
 at T<10 °C; T>40°C 0.1%/K additional

Output 2: temperature

Measuring element (ref. DIN IEC 751) Pt 100 class B
 Output range 1: -20...+80 °C
 (special models with special measuring range on demand)
 Output signal 2: 4...20 mA
 Accuracy at 23°C.....±0.2 K
 other range.....±0.3 K
 at T<10°C, T>40°C ±0.007 K/K additional

Description

MELA-Humidity/temperature sensors in these series are used to measure relative humidity or temperature or relative humidity and temperature in air and other non-aggressive gases in explosion hazardous areas and in locations with inflammable dust.

The sensors comprise a sensor part with a sintered filter mounted on a robust aluminium die-cast housing (transmitter part), both made of stainless steel.

Connection to a non-intrinsically safe electric circuit for humidity (F*C3.Ex/8) and for temperature sensors (T*C3.Ex/8) is achieved with a 1-channel transmitter power supply unit and for the combined humidity and temperature sensors(K*C3.Ex/8) either with a 2-channel or with two 1-channel transmitter power supply units with galvanic isolation between input-/output circuits and power supply.

Model variants - product reference

Measured variable	GC series	KC series
F (relative humidity)	FGC3.Ex/8	FKC3.Ex/8
K (rel. humidity / temp.)	KGC3.Ex/8	KKC3.Ex/8
T (temperature)	TGC3.Ex/8	TKC3.Ex/8
weight approx.	380 g	470 g

II 1/2 G Ex ia IIC T4 Ga/Gb

II 2D Ex ia IIIC T95°C Db

-40°C ≤ T_a ≤ +80°C

Approved for use in explosion hazardous areas :

EC Design Test Certificate
 IBExU 07 ATEX 1114

Others

Storage temperature -40...+80°C
 Approved operating temperature range -40...+80°C
 Maximum surface temperature of housing 95°C
 Sensor operating voltage 13...24V DC (intrinsically safe)

Maximum admissible input voltage U_i 24V DC
 Maximum admissible input amperage I_i 100 mA
 Maximum admissible input power P_i 780 mW
 Maximum inner capacity C_i negligible
 Maximum inner inductivity L_i negligible
 Degree of protection IP 66
 electrical equipment in instrument group II with protection provided by housing

Housing material

Sensor part stainless steel
 Transmitter part alu-diecast
 Cable screwing M16 x 1.5
 clamping range 3...7 mm
 initial torque
 (for recommended cable type) 4.0 Nm

Cable between sensor and transmitter power supply unit, shielded
 Recommended type NF14 (Metrofunk)
 Maximum power transmission length 200 m
 Maximum cable capacity 20nF/100 m
 Ends of the power line Wire sleeves with plastic collars

Recommended transmitter power supply units

by Hans Turck GmbH & Co. KG

IM33-11Ex-Hi/24V DC (1-channel)

IM33-22Ex-Hi/24V DC (2-channel)

All data and certificates at www.turck.com

Conformity with European Standards

Explosion protection guideline **2014/34/EU**
 General requirements EN IEC 60079-0:2018
 Intrinsic safety „i“ EN 60079-11:2012

Directive about electromagnetic compatibility 2014/30/EU

General requirements EN 61326-1:2013
 Special requirements EN 61326-2-3:2013

Assembly instructions

MELA-humidity/temperature sensors should be installed in a location which is representative for measuring the environmental conditions.

Connection to a non-intrinsically safe power circuit is achieved by using either one or two transmitter power supply units (U_0, I_0, P_0) according to the connection diagram. To verify the intrinsic safety in a simple, intrinsically safe electric circuit, the values of the intrinsically safe equipment (U_i, I_i, P_i, C_i and L_i), of the corresponding electrical equipment (transmitter power supply U_0, I_0, P_0, C_0 and L_0) and of the cable (C and L) need to be compared to ensure that the intrinsically safe equipment is not overloaded and the energy stores L and C are not greater than L_0 and C_0 of the corresponding equipment. For the performance, even with a trapezoidal characteristic curve, the value P_0 of the transmitter power supply is to be used.

Basically, the max. cable length only depends on C_0 of the transmitter power supply and on the type of cable used, as circuit engineering measures have been taken to ensure that the internal capacity of the sensor does not impact externally. We recommend the cable type NF14 and a max. cable length of 200m. During installation, the additional requirements for the

protection type „i“ -intrinsically safe according to DIN EN 60079-14, - must be complied with. Only fixed cables and electric lines may be inserted into the cable gland. After connecting it up, the housing must be sealed tightly again. To do so, the screws in the cover must be tightened with a torque of 1.5 to 2.0 NM.

The intrinsically safe humidity and temperature sensors (type of protection „ia“) can also be used as class 1 equipment. If you do this, make sure you only use assembly kit **ZA40** when attaching the sensor to a partition barrier.

Please order assembly kit **ZA40** separately! Please refer to pages 3 and 4 for further safety advice and dimension diagrams for connecting to zone 0.

The sensor can be installed in any position. However, do avoid positions where water ingress can occur. Dew formation and splashes do not damage the sensor, although corrupted measurement readings are recorded until all the moisture on and directly around the sensor element has dried up.

In order to maintain immunity from interference while using the sensor, you are required to connect up the sensor with a screened cable which has been fitted into the sensor's EMC cable gland by a qualified electrician.

Dimensions

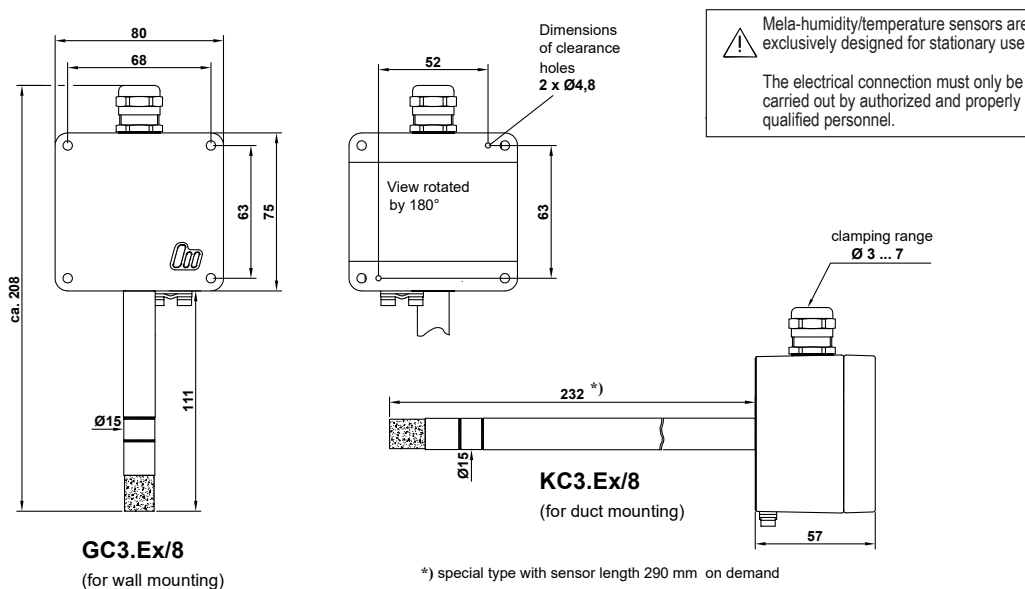

*) special type with sensor length 290 mm on demand

Connection diagrams

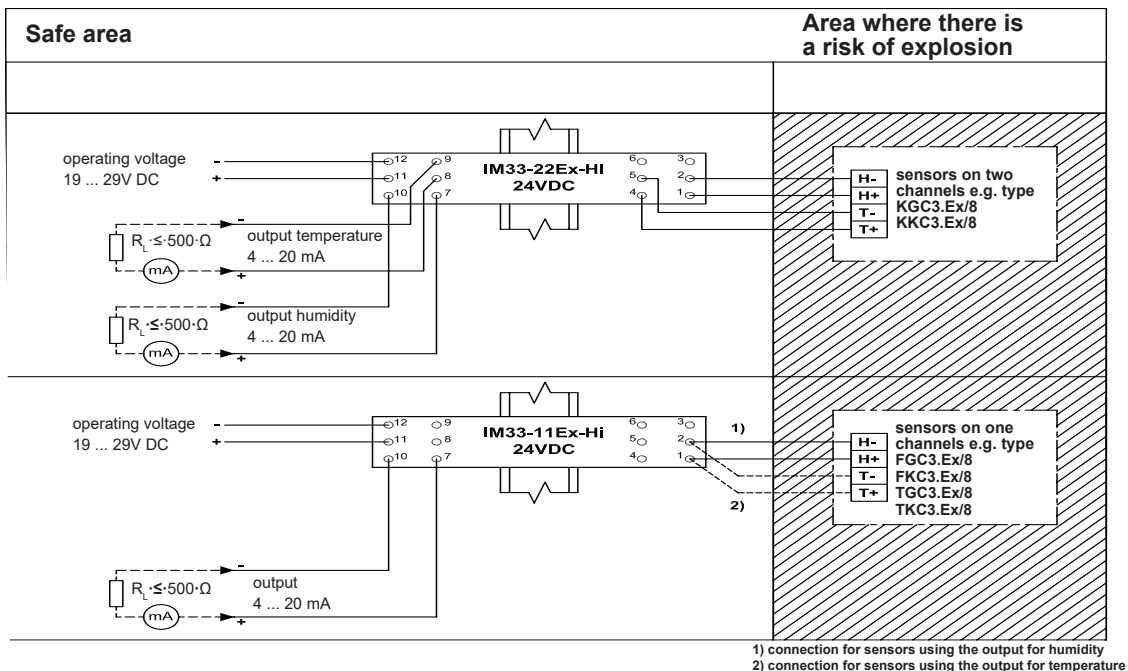

1) connection for sensors using the output for humidity
2) connection for sensors using the output for temperature

Installing a humidity and temperature sensor with connection to zone 0

The **MELA-humidity/temperature sensor** is to be mounted in the wall of the hazardous area with class 1 requirements by using assembly kit ZA 40 and according to the dimension diagram showing connections to zone 0 on page 4, .

This partition barrier must be made of corrosion-resistant material compatible with the application, must be homogeneous and have a wall thickness of at least 3 mm, and must have a thread of M25x1,5.

Otherwise additional protection measures are necessary in accordance with DIN EN 60079-26 .

When the sensor is removed there is a danger of releasing potentially explosive atmosphere and flames penetrating from the outside. For this reason the opening must be closed again immediately.

Only attach the humidity and temperature sensors using the increased safety-type cable gland provided in the assembly kit **ZA 40**.

Please order assembly kit **ZA 40** separately.

The screw connections are to be tightened using a tool with a tightening torque of 10 Nm.

When removing the sensor, the increased safety-type cable gland stays in the partition barrier. The opening is closed again by simply replacing the normal seal insert with the increased safety-type filler seal insert from the assembly kit **ZA 40**.

Special models

On request **MELA-humidity/temperature sensors** with „Ex“ certification can also be supplied with the following options:

Connecting cable Ø 6...10 mm	all model versions
stainless steel/teflon filter ZE28 for extreme applications	all model versions
290 mm long sensor tube	series KC
Special measurement ranges with Temperature (0 ... 50°C, 0 ... 100°C and -30...70°C)	model versions K*C3.Ex/8 and T*C3.Ex/8

Maintenance and Cleaning

If used as intended and if the assembly instructions and ambient conditions have been taken into consideration, then no running maintenance is necessary.

In order to arrange a simple test of the functionality of the sensor on the site, we recommend the **MELA-humidity standard type ZE 31/1** with the **additional adapter type ZE 33** (product information no. F 5.2).

Dust does not damage the sensor but it negatively affects its dynamic behaviour.

The sintered filter can be carefully unscrewed and washed out if too much dust accumulates.

Loose dirt can also be removed from the measuring element by blowing or carefully flushing with distilled water. The sintered filter should be in an absolutely dry condition when it is screwed on again in order to avoid measurement errors. It is important not to touch the highly sensitive sensor element in the process. The screw connection on the sintered filter has to be firmly tightened.

Please refer to the **application instructions** for the sensing elements (product info sheet no. A 1) or check with the manufacturer for further information that you need to be aware of when using humidity sensors with capacitive sensing elements.

Caution!

Do not open sensors in a location with explosive dust atmosphere!

Repair

MELA humidity and temperature sensors with „ATEX“ certification may only ever be repaired by the manufacturer. The manufacturer will only use type-tested components as replacement parts.

While observing the following safety advice, the customer is only allowed to recalibrate the sensors.

Safety Information

The sensor may only be opened and operated while open when it is not in the potentially explosive atmosphere.

After calibration, the housing must be sealed tightly again. To do so, the screws in the cover must be tightened with a torque of 1.5 to 2.0 NM.

Potentiometer Configuration

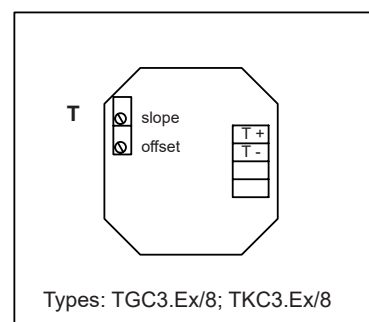
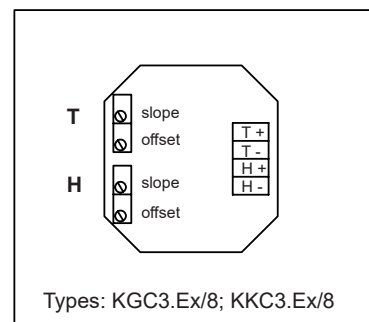
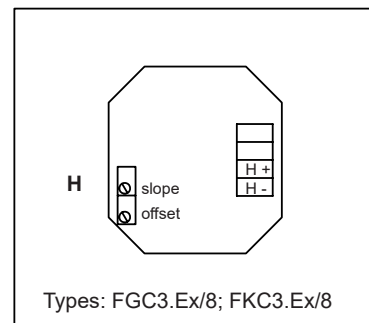

Dimension diagrams for connection to zone 0

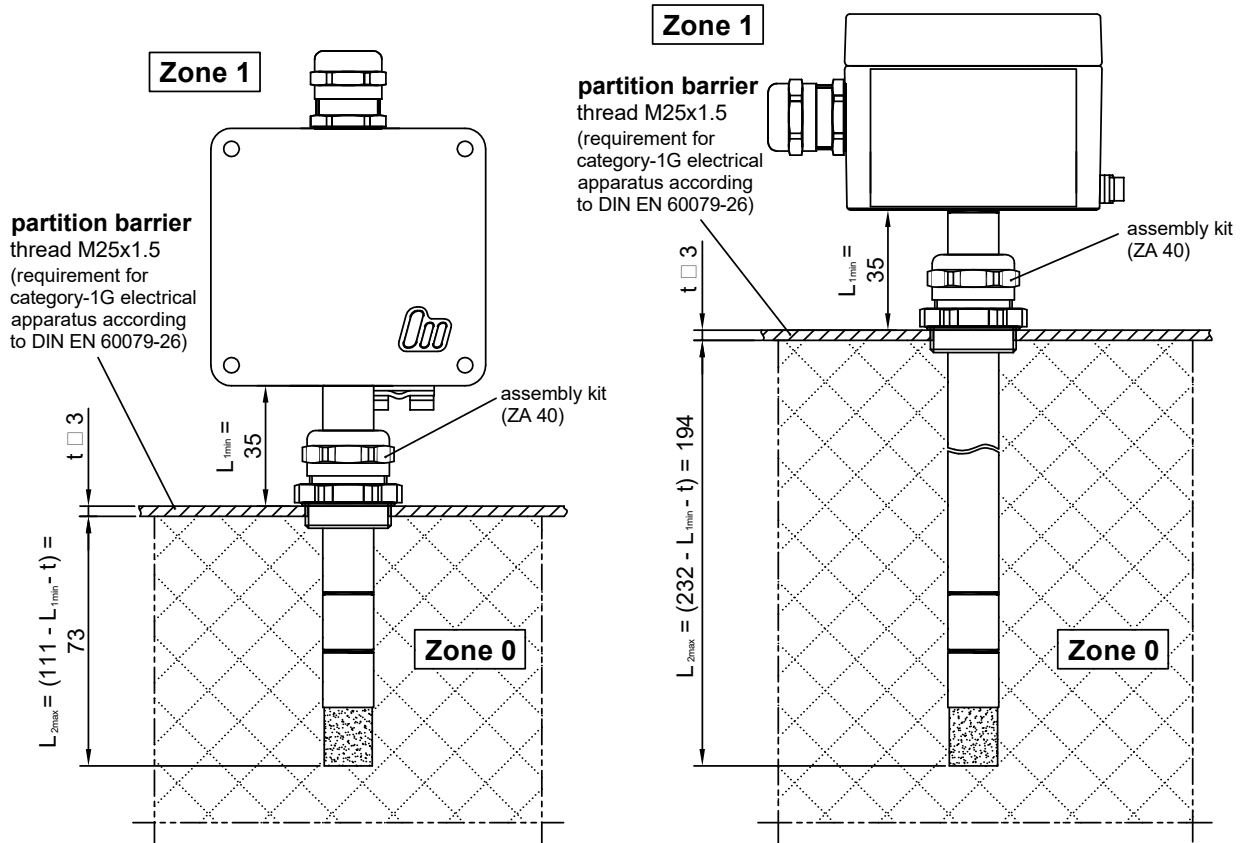

series

GC3.Ex/8

(for wall-mounting)

KC3.Ex/8

(for duct mounting)

Assembly kit

ZA 40

for connection to zone 0
(please order separately)

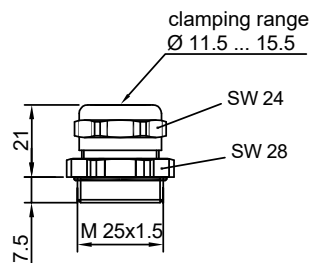

"increased safety" type cable gland

for sensor mounting in partition barrier



seal insert, closed

to close the opening in the partition barrier after removing the sensor



Electrical connections must only be carried out by properly qualified personnel.

Attention must be paid to requirements for category -1G electrical apparatus according to DIN EN 60079-26 and also to installation advice.

When the sensor is removed there is a danger of releasing potentially explosive gas mixtures and flames penetrating from the outside.

PAQUIN
SENSORS