



Transmitter for humidity and temperature measurement with remote probe

D series with remote probe

Type **DZK**

- probe up to +125 °C
- up to 25 m cable length
- calibrated probe, cabled and exchangeable
- easy to install
- output of derived hx values
- in situ alignment
- optional USB interface

Technical data

Humidity	
Measuring range	0...100 % RH
Measuring uncertainty	±2 % RH additional ≤±0.2 % RH / % RH
10...90 % RH at 25 °C	
< 10 % RH or > 90 % RH at 25 °C	
Long term stability	≤0.5 % RH/a
Hysteresis	≤±1 % RH
Typ. temperature influence at 25 °C	±0.02 % RH/K

Electrical data	
Electrical outputs	Voltage supply U_B
2 x 0...10 V	15 ... 30 V DC / 13 ... 26 V AC
2 x 4...20 mA	10 ... 30 V DC ensure galvanic isolation from the power supply
Consumption of electronics (voltage output)	typ. 7 mA
Load resistance (voltage output)	≥ 10 kΩ
Load R_L (current output)	
$R_L(\Omega) = \frac{\text{voltage supply} - 10 \text{ V}}{0,02 \text{ A}} \pm 50 \Omega$	

Electromagnetic compatibility	2014/30/EU
DIN EN 61326-1	
DIN EN 61326-2-3	

Temperature	
Measuring uncertainty +5...+60 °C	typ. ±0,2 K max ±0,35 K
at airspeed across to the sensor with filter:	V_{min} (V_{max}) in m/sec
ZE08	≥0,5 (≤ 10)
ZE05	≥1,5 (≤ 20)
Influence of temperature ref. to +5 °C or +60 °C	
-40... +5 °C	≤12mK/K
+60... +80 °C	≤14mK/K
+60...+100 °C	≤14mK/K
+100...+125 °C	≤20mK/K

2 analogue signal outputs (freely configurable via optional USB interface)	
Relative humidity	0...100 % RH
Temperature	0 ... + 50 °C -30 ... + 70 °C 0 ... +100 °C
Sensor head high temperature	-40 ... +125 °C more on request
Dew point temperature	-20... +70 °C
Enthalpy	0... 80 kJ/kg
Mixing ratio	0...100 g/kg dry air
Absolute humidity	0... 20 g/m ³ or 0...100 g/m ³
Wet-bulb temperature	-10... +50 °C





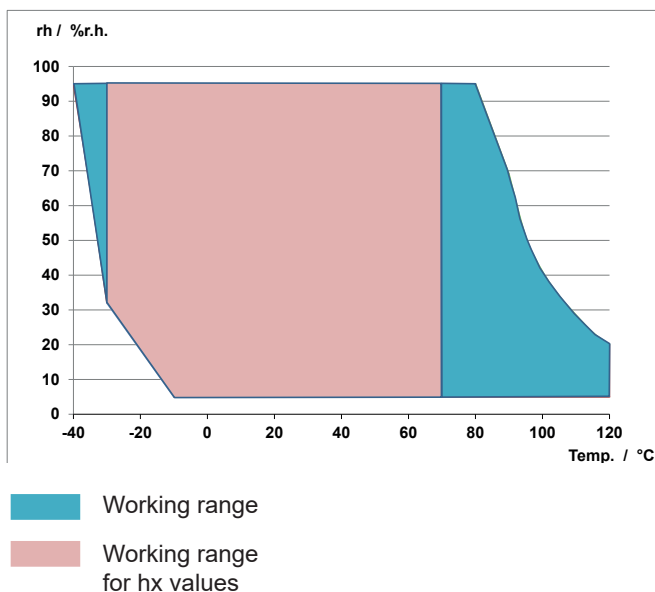

General data	
Measuring medium	Air, non-aggressive non-pressurised non-condensing
Max. air speed protective cage with membrane (ZE08)	10 m/s standard
Operating temperatures	
wall mounted device with display	- 30... + 80 °C
wall mounted device without display	- 40... + 80 °C
probe (standard)	- 40... + 85 °C
probe and cable firmly connected	- 40... + 80 °C
probe high temperature	- 40... +125°C
Storage temperatures	- 40... + 80 °C
Connection: Connecting terminals	
wire diameter per connector	max. 1,5 mm ²
total diameter cable	4 - 8 mm
Degree of protection / probe	
with membrane filter ZE08 (standard)	IP30
PTFE sintered filter up to 125°C (optional)	IP65
Degree of protection / housing	IP 65
Safety category	III
Material of housing	PC
Cable sensor	PC
Cable length of remote probe	2 / 5 / 10 / max. 25 m
Display	2 lines 3 digits + 1 decimal place display approx. 21 x 40 mm ² digit height approx. 8 mm

Working range humidity and temperature

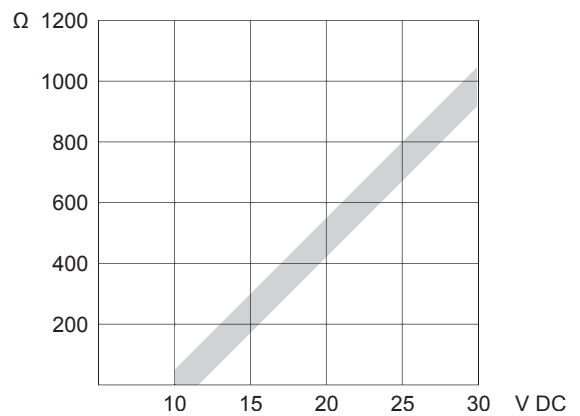

Load at current output

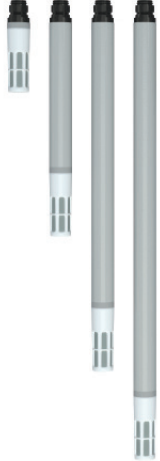

Transmitter	Probe pluggable	Probe with cable	Accessories
For wall mounting with integrated connector	with female socket	with female cable	connecting cable pluggable on both sides
<p>80 °C IP 65</p> 	<p>85 °C</p>  <p>85 °C protective cage, IP30 with membran filter (ZE08)</p> <p>IP65 option PTFE-sintered filter, IP65</p>	<p>85 °C 125 °C 125 °C</p>  <p>(Image: High temperature version with IP65)</p> <p>85 °C protective cage, IP30 with membran filter (ZE08)</p> <p>125 °C IP65 For high temperature version PTFE-sintered filter, IP65</p>	<p>85 °C 80 °C</p>  <p>IP65 when plugged</p>
with display -30...+80 °C without display -40...+80 °C IP65 (when plugged)	4 probe lengths: S, M, L, XL -40...+85 °C IP30 with protective cage IP65 with PTFE-sintered filter (when plugged)	3 probe lengths: S, M, L -40...+125 °C (probe+cable) IP30 with protective-cage IP65 mit PTFE-sintered filter (when plugged) cablelength 2m / 5m / 10m / 25m (pluggable in the housing)	female cable / - connector cablelength 2 / 5 / 10 / 25m -40...+80 °C

Accessories

Product n°	Description
20.078	sintered filter ZE05 (instead of ZE08) made of fine-pored PTFE, IP 65
20.077	PTFE sintered filter ZE05 with O-Ring, IP65 - spare part
20.045	fixing flange, synthetic material, with fixing mechanism for easy sensor mounting and removal for sensors Ø 12 mm, with rubber sealing
ZE 31/1-12 ZE 31/1-75	humidity standard to check the accuracy of the sensor at 12 % RH humidity standard to check the accuracy of the sensor at 75 % RH
ZE 31/1-33 ZE 31/1-84	humidity standard to check the accuracy of the sensor at 33 % RH humidity standard to check the accuracy of the sensor at 84 % RH
ZE36	testing adapter for humidity standards for sensor tubes Ø 12 mm

Dimensions

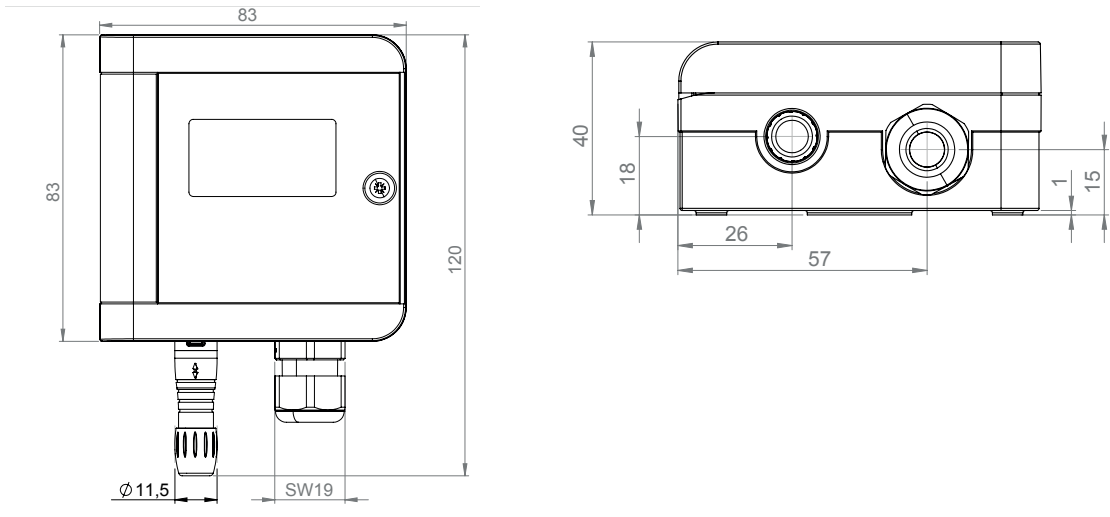

Drilling pattern

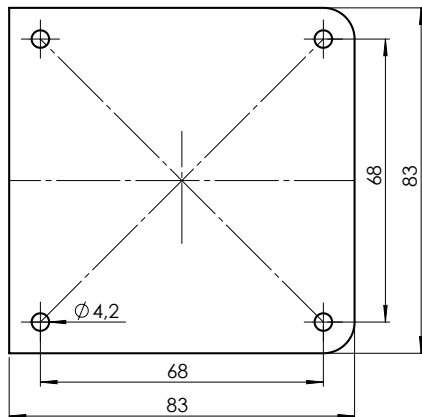

Fixing flange (accessories)

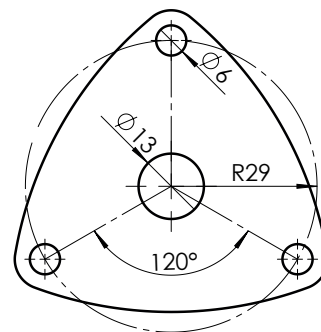

drilling pattern of fixing flange

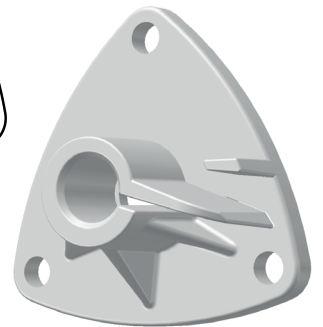

Connection diagrams

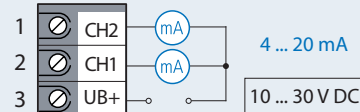
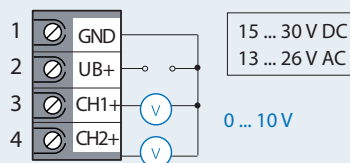

galvanic isolation from the power supply necessary for USB!

ESD protection advice

The sensors of the D series contain components, which can be damaged by the effects of electrical fields or by charge equalisation when touched.

The following protective measures must be taken when the housing of the sensor is to be opened for connection or in situ alignment:

- Before opening the housing of the sensor, ensure electrical potential equalisation between you and your environment.
- Pay particular attention to ensure that this potential equalisation is maintained while you are working with the opened housing.



Probe with cable

probe lengths: $S = 78$
 $M = 150$
 $L = 220$ } for IP65 (PTFE-sintered filter)
 add another + 4 mm

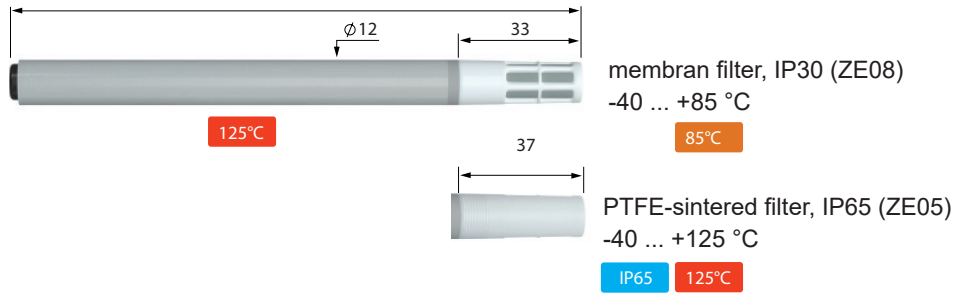

S = 78 mm + 4 mm (for IP65 filter)

M = 150 mm + 4 mm (for IP65 filter)

L = 220 mm + 4 mm (for IP65 filter)

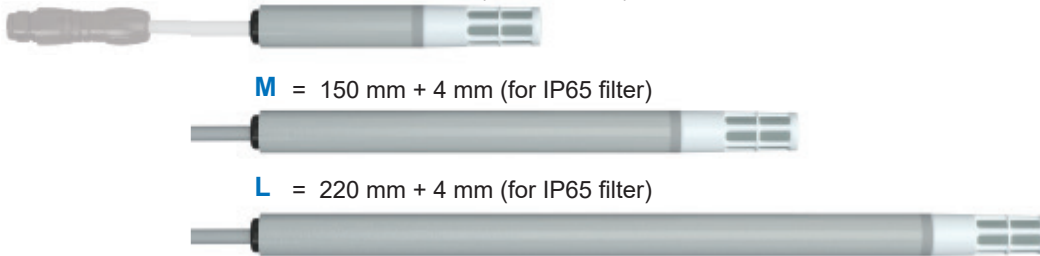

Probe pluggable

(not possible for cable probe high temperature +125 °C)

Probe lengths: $S = 78$
 $M = 150$
 $L = 220$
 $XL = 266$ } for IP65 (PTFE-sintered filter)
 add another + 4 mm

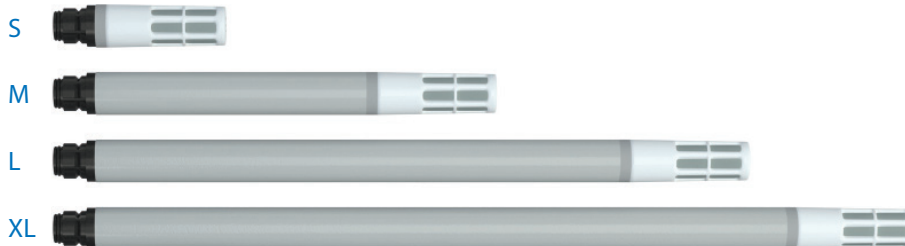
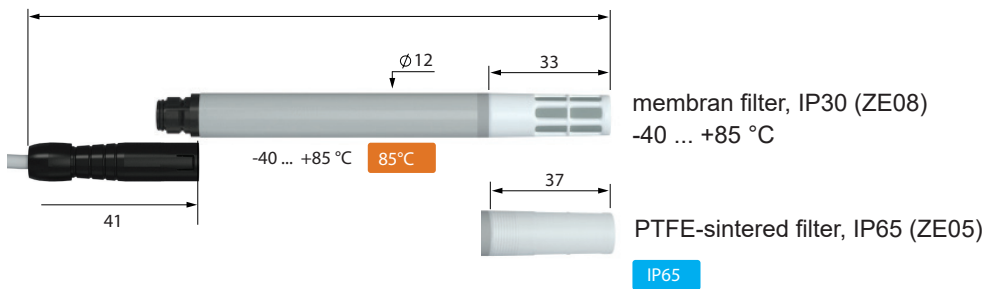

(Instruction for transmitters without USB interface)

During the in situ alignment the sensor does not necessarily have to be taken out of the control circuit.

We offer humidity standards for alignment of the sensors (page 3: accessories). Before calibrating the sensor, standards should remain at least 2 hours on the sensors.

The temperature must remain constant during this time. For the correct temperature according to the humidity standard used, please refer to data sheet F 5.2 Humidity Standards. During calibration temperature and humidity must remain constant.

During calibration, especially during storage of data, uninterrupted power supply of the sensor must be provided.

During calibration the following measurement ranges are shown on the display / are used for calibration:

CH 1:	all sensors	always: Relative humidity, measuring range 0...100 % RH
CH 2:	sensors, with relative humidity RH output and temperature °C output	the programmed temperature range, unaltered
	sensors, with other hx-values outputs	the standard temperature measuring range of -40...85 °C

Command		Operation	Transmitter / LED
default attention: All user adjustments will be reset.	possible only when adjustment mode is off (LED must not be lit.)	press buttons UP and DOWN simultaneously for at least 8 sec.	until LED lights up for 1 sec.
calibration mode	selection of the calibration mode	press button DOWN for at least 3 sec.	until LED blinks 1 time per second
selection of type of calibration	humidity 1-point-adjustment (offset)	no further command necessary	LED blinks 1 time per second
	humidity 2-point-adjustment lower point at 12 % RH and 20...30°C humidity standard ZE31/1-12	press button DOWN 1 time shortly	LED blinks twice per second
	humidity 2-point-adjustment upper point at 75 % RH 20...30°C humidity standard ZE31/1-75	press button DOWN twice shortly	LED blinks 3 times per second
	temperature 1-point-adjustment	press button DOWN 3 times shortly	LED blinks 4 times per second
Confirmation of selection		press button DOWN for at least 3 sec.	until LED lights up permanently
adjustment		buttons UP / DOWN: (press shortly) +/-0.1 % RH respectively +/-0.1°C per keystroke	
saving		press button DOWN for at least 3 sec.	until LED is off
program termination (at any time)		press button UP for at least 3 sec.	until LED blinks 6 times and then switches off

Option: Transmitter USB interface



General information:

The following settings can be made using the „Galltec+Mela USB Configuration Software“ and a standard micro USB cable. The transmitter is powered via USB. Except for adjustments, the transmitter requires no power via a power supply unit.

- Change of physically measured values
- Change of analogue output scaling / measuring range
- Change of temperature variables to °C or °F
- Air pressure input
- Single point adjustment of temperature and relative humidity

Downloads

Software:	https://galltec-mela.de/en/downloads/
System requirements	<p>Operating system: Win 10 / Win 8 / Win 7 / Win Vista / Win XP</p> <p>USB-Port: USB 2.0</p> <p>Software license agreement: https://galltec-mela.de/en/downloads/</p>
Galltec Configuration Manual:	https://galltec-mela.de/en/downloads/

Connecting Cable (not part of the standard delivery)



Standard USB micro cable
- USB „A“ plug to USB „micro B“

Registration in Windows:

The transmitter is automatically registered in Windows via the USB cable after connecting to the PC. **No drivers are required.** Only one Galltec+Mela transmitter can be configured and adjusted at a time.

Warning:



If the transmitter has current outputs (4-20mA) and an USB interface ensure galvanic isolation between PC and power supply on the connection terminals of the sensor (see separate Galltec Configuration Manual „USB Configuration Manual“ at <https://galltec-mela.de/en/downloads/>).

We recommend the use of an USB isolator. We successfully tested: <https://de.muc89.com/isar520> for that purpose. With this USB isolator please leave the jumpers in the delivery state for the USB full speed mode we use.

Change of physical measuring values and analogue output scaling:

- Based on the measured sizes of relative humidity and temperature you can select the below listed derived physical values
- All temperature values can be displayed in °F or °C
- The scaling of the physical values can be freely selected within the limits below
- The sensor is powered via USB for configuration - no power supply unit is required

Physical values:	Scaling ranges:
Relative humidity [% RH]	0 % RH 100 % RH
Mixing ratio	0 g/kg 100 g/kg
Dew point temperature [°C] / [°F]	-20 °C +70 °C -4 °F +158 °F
Enthalpy [kJ/kg]	0 kJ/kg 80 kJ/kg
Absolute humidity [g/m ³]	0 g/m ³ 100 g/m ³
Wet bulb temperature [°C] / [°F]	-10 °C +50 °C +14 °F +122 °F
Temperature [°C] / [°F]	-100 °C +200 °C -148 °F +392 °F

Air pressure and altitude:

For the following physical values, the air pressure is relevant to obtain a correct reading:

- Mixing ratio [g/kg]
- Enthalpy [kJ/kg]
- Wet bulb temperature [°C/°F]

If a physical value is selected, for which the air pressure is relevant, the input field automatically appears. The air pressure can be entered either directly or indirectly via the altitude (m above sea level).

Adjustment:

The transmitter can be matched to the measuring task by means of adjustment.

To do this, supply the transmitter with power via the connection terminal and connect to the PC.

This can also be done in situ using a portable computer.

There are two types of adjustment:

1. Offset adjustment: An offset in temperature and / or relative humidity can be entered. Actual values are adjusted by this offset.
2. Adjustment with reference: By entering reference measuring values, sensor readings are adjusted to the reference.

Warning: 	see warning concerning galvanic isolation
---	--

Information:

The measuring accuracies specified in the technical data refer exclusively to factory adjustments.

The adjustment values in T & RH influence all physical values.

Mounting instructions

Position	The installation site of the remote probe should be chosen such that a representative measurement of air humidity can be guaranteed. Avoid areas in the vicinity of radiators, doors and exterior walls as well as direct sunlight.
	Do not position the sensor where ingress of water could occur. IP65 protection is: - only ensured with PTFE sintered filter ZE05 with O-Ring - only ensured when the probe is plugged, see „Probe pluggable“ on page 5
	To close the housing securely turn screw until dead stop.
	We recommend that you lay the connection lines in a loop so that any water that may be present can run off.
Operating temperature	Please note the maximum permissible ambient temperature for probe and housing when installing the sensor. When firmly connected the standard cable must not be exposed to an increased ambient temperature > +80 °C.
Connection	The electrical connection must be carried out by qualified personnel only.
	The sensor contains sensitive electrical components. When opening the housing, make sure you comply with the electrostatic discharge precautions (ESD).
	Please pay attention to the ohmic resistance according to the operating voltage when using sensors with a current output.
	Lines to and from the sensor must not be installed parallel to strong electromagnetic fields.
	If there is any chance of an electrical surge, please install surge protection devices.

User instructions

Cleaning of filters and protective baskets	If necessary, soiled filters and protective baskets can carefully be unscrewed and rinsed. Bear in mind the sensors will not measure accurately again until filters are completely dry.
Damaging influences	Depending on type and concentration, agents that are corrosive and contain solvents, can result in faulty measurements and can cause the sensor to break down. Substances deposited on the sensor (e. g. resin aerosols, lacuer aerosols, smoke deposits etc.) are damaging as they eventually form a water-repellent film.
Exchanging the measuring probe	After the exchange of the measuring probe reset the adjustment or adjust again. The in situ alignment refers to the transmitter in conjunction with the remote probe.



This information is based on current knowledge and is intended to provide details of our products and their possible applications. It does not, therefore, act as a guarantee of specific properties of the products described or of their suitability for a particular application. It is our experience that the equipment may be used across a broad spectrum of applications under the most varied conditions and loads. We cannot appraise every individual case. Purchasers and/or users are responsible for checking the equipment for suitability for any particular application. Any existing industrial rights of protection must be observed. The quality of our products is guaranteed under our General Conditions of Sale. Data sheet DZK_e. Issue: August 2024. Subject to modifications.

