

Overview

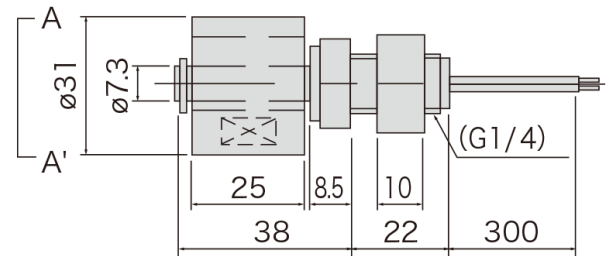
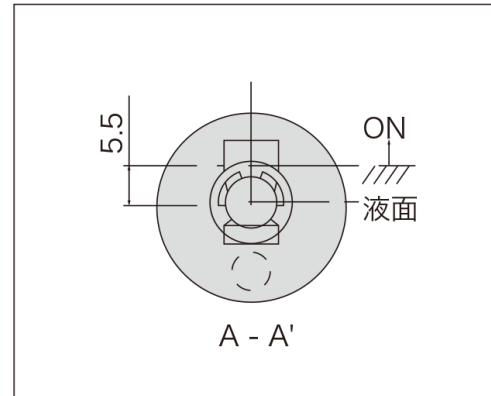
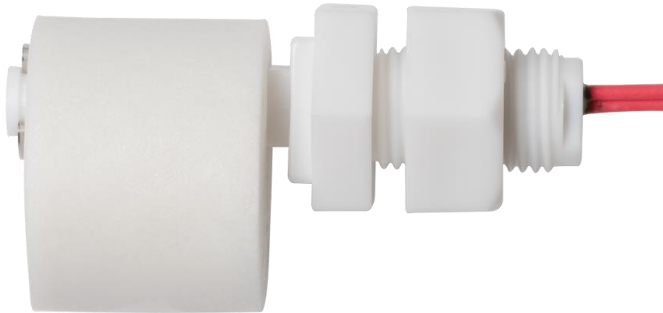

Description

The P309 is a side-mounted float-type level switch designed for reliable liquid level detection in various industrial applications. Its durable plastic housing and compatibility with water and chemical solutions make it a versatile choice for monitoring liquid levels.

Technical Parameters

| | | |
|-----------------------|--|---|
| Material | Stem | P.P. |
| | Float | P.P.Foamed |
| | Stopper | SUS304 (P.P.) |
| | Nat | P.P. |
| Specifications | Temperature Range (Atmospheric) | -10°C~+80°C |
| | Pressure Resistance (Room Temperature) | 0.2MPa |
| | Float Specific Gravity | 0.7±0.05 |
| Electric Specs | Maximum Contact Capacity | 50W DC/AC |
| | Maximum Voltage | 300V DC/AC |
| | Maximum Current | 0.5A DC/AC |
| | Wire Length | 300mm Standard (Custom lengths available) |