

# Overview

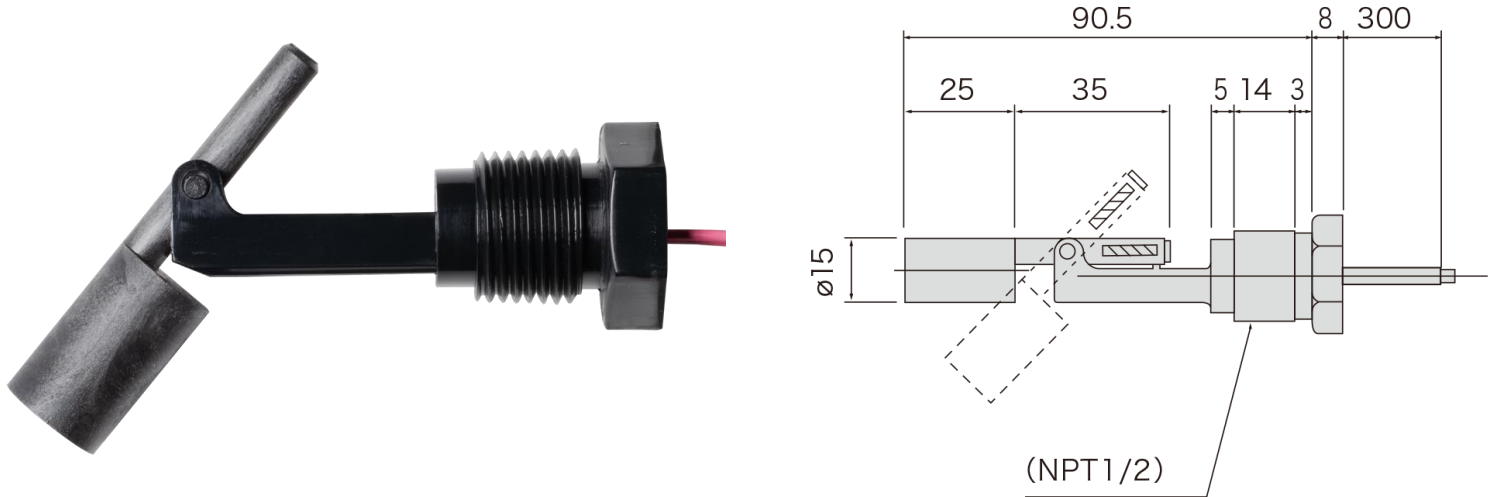

## Description

The P303 is a side-mounted float-type level switch designed for precise liquid level detection in various industrial applications. Its robust plastic housing and compatibility with high-temperature environments make it a reliable choice for monitoring liquid levels in tanks.

## Technical Parameters

<b>Material</b>	Stem	6-N
	Float	6-NFoamed
	Stopper	—
	Nat	—
<b>Specifications</b>	Temperature Range (Atmospheric)	-10°C~+110°C
	Pressure Resistance (Room Temperature)	0.2MPa
	Float Specific Gravity	0.7±0.05
<b>Electric Specs</b>	Maximum Contact Capacity	50W DC/AC
	Maximum Voltage	300V DC/AC
	Maximum Current	0.5A DC/AC
	Wire Length	300mm Standard (Custom lengths available)