

Overview

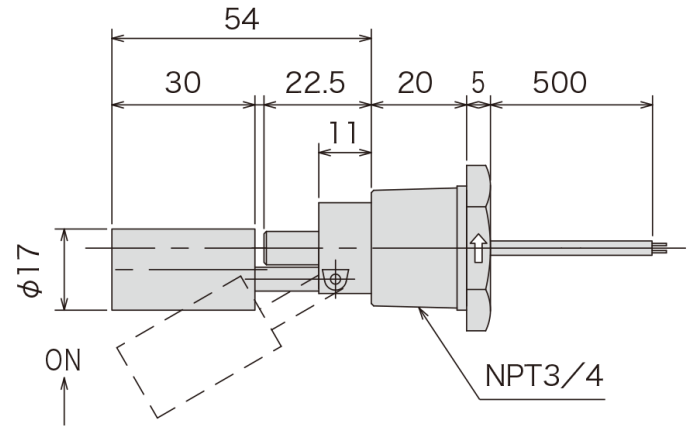
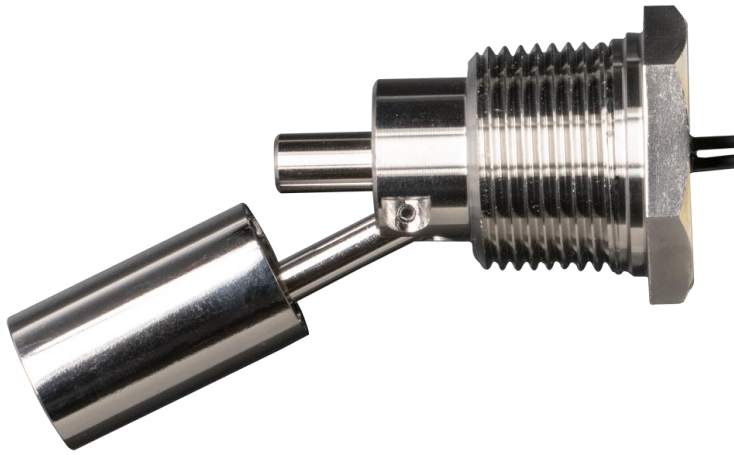

Description

The P296 is a compact, side-mounted float-type level switch designed for precise liquid level detection in various industrial applications. Constructed entirely from SUS304 stainless-steel, it offers durability and compatibility with water, oil, and chemical solutions.

Technical Parameters

Material	Stem	SUS304
	Float	SUS304
	Stopper	SUS304
	Nat	SUS304
Specifications	Temperature Range (Atmospheric)	-40°C~+120°C
	Pressure Resistance (Room Temperature)	0.5MPa
	Float Specific Gravity	0.8±0.05
Electric Specs	Maximum Contact Capacity	1W DC/AC
	Maximum Voltage	24V DC/AC
	Maximum Current	0.1A DC/AC
	Wire Length	300mm Standard (Custom lengths available)