

Overview

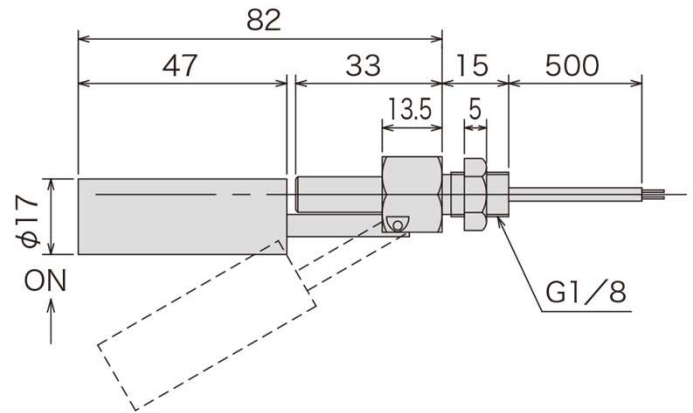

Description

The P290 is a stainless-steel float-type level switch designed for easy side-mount installation, suitable for various industrial applications requiring reliable liquid level detection.

Technical Parameters

Material	Stem	SUS304
	Float	SUS304
	Stopper	SUS304
	Nat	SUS304
Specifications	Temperature Range (Atmospheric)	-40°C~+120°C
	Pressure Resistance (Room Temperature)	0.5MPa
	Float Specific Gravity	0.7±0.05
Electric Specs	Maximum Contact Capacity	50W DC/AC
	Maximum Voltage	300V DC/AC
	Maximum Current	0.5A DC/AC
	Wire Length	300mm Standard (Custom lengths available)