

# Continuous Level Transmitter

- 4...20mA and 0...10VDC
- For liquids, bulk solids, and powders
- Visual LED status indication
- Electrodes with special coatings for aggressive media
- Designs for conductive and non-conductive media
- Threaded and Tri-clamp process connections
- Operates effectively up to 572°F (300°C)



## About

The P107 Continuous Level Transmitter is designed for precise and continuous level measurement of liquids, bulk solids, and powders. It can be installed in various industrial settings such as tanks, hoppers, and silos, with flexible mounting options and robust protection against harsh conditions. The device supports multiple output types (4–20 mA current or 0–10 V voltage) and is configurable using a magnetic pen, eliminating the need for emptying the tank during setup. Additionally, it offers high-temperature variants, ensuring reliability and safety across diverse applications.

## Applications

- ✓ Food & Beverage
- ✓ Chemical Refining & Manufacturing
- ✓ Pharmaceuticals
- ✓ Oil & Gas
- ✓ Biomedical
- ✓ Water & Wastewater
- ✓ Hazardous Mining
- ✓ More

# Build Your Part Number

## Series P107

Example: P107SE11.7P1A54

<b>Series</b>
P107

<b>Hazard Performance - select one</b>	
<b>S</b>	Standard atmosphere (non-explosive)
<b>SH</b>	For standard atmosphere (non-explosive) in high temperature environments
<b>E</b>	For explosive environments
<b>M</b>	For mining environments
<b>EH</b>	For high temperatures in an explosive environments
<b>MH</b>	For high temperatures in a mining environments

<b>Electrode - select one; see diagrams on page 7</b>	
<b>E1</b>	Rod, uncoated, length 0.1 ... 2 m
<b>E2</b>	Rod, fully coated (FEP), length 0.1 ... 2 m
<b>E3</b>	Rod, fully coated (PFA), length 0.1 ... 2 m
<b>E4</b>	Rod, fully coated (PFA), length 0.1 ... 2 m with higher pressure and mechanical resistance at high temperatures; only available with Tri-clamp process connection if "SH" Hazard Performance is also selected
<b>E5</b>	Rod, uncoated, length 0.1 ... 3 m
<b>E6</b>	Rod, fully coated (FEP), length 0.1 ... 3 m
<b>E7</b>	Rod, uncoated with ref. tube, length 0.1 ... 1 m (cannot be selected with Tri-clamp process connections)
<b>E8</b>	Rod, fully coated (FEP) with ref. tube, length 0.1 ... 1 m (cannot be selected with Tri-clamp process connections)
<b>E9</b>	Rope with weight, uncoated, length 1 ... 6 m (cannot be selected with Tri-clamp process connections)
<b>E10</b>	Rope with weight, coated (FEP), length 1 ... 10 m

<b>Electrode Length - select one</b>	
<b>XX</b>	Electrode length in meters (Example: 1.5 meters = 1.5)

<b>Process Connection - select one; see diagrams on page 7</b>	
<b>P1</b>	¾" NPT male
<b>P2</b>	G ¾" male
<b>P3</b>	G 1" male
<b>P4</b>	Metric Thread M 30x1.5
<b>P5</b>	Metric Thread M 27x2
<b>P6</b>	¾" Tri-clamp (ø 34 mm) (cannot be selected with Electrode E7, E8, and E9)
<b>P7</b>	1.5" Tri-clamp (ø 50.5 mm) (cannot be selected with Electrode E7, E8, and E9)

<b>Output - select one</b>	
<b>A</b>	Current 4 ... 20 mA (non-explosive hazard performance only)
<b>C</b>	Voltage 0 ... 10 V (For all explosive and mining environment hazard performance only)

<b>Electrical Connection - select one; see diagrams on page 8</b>	
<b>1</b>	Short stainless-steel gland
<b>2</b>	Plastic threaded cable gland
<b>3</b>	M12
<b>4</b>	Metal dust proof terminal
<b>5</b>	Plastic cable gland with spiral
<b>6</b>	Plastic cable gland for protective hose

<b>Cable Length - required with electrical connections 1,2,4,5,6 otherwise please skip</b>	
<b>XX</b>	Cable length in meters (Example: 7 meters = 7) Note: standard cable length = 2 meter

**Note:** Product Includes 1 magnetic pen and 1 asbestos free seal

<b>Accessories - optional; will be quoted as a separate line item</b>	
<b>SF</b>	Standard steel welding flange for process connection options P1, P2, P3, P4, P5
<b>SSF</b>	Stainless-steel welding flange for process connection options P1, P2, P3, P4, P5

# Technical Parameters

Technical Parameters			
<b>Electrical</b>	Current output	4 ... 20 mA (2-wire) / Supply 9...34 VDC	
	Voltage output	0 ... 10 V (3-wire) / Supply 12...34 VDC Ex atmosphere versions: Supply 9...30 VDC	
	Power consumption	Standard Atmospheres: 5 mA (voltage output open circuit) Ex Atmospheres: 3.75 ... 20.5 mA	
	Non-linearity	Maximum 1%	
	Temperature error	Maximum 0.05%/K	
	Voltage error for current and voltage output	Maximum 0.3 $\mu$ A/V a 0.1 mV/V	
	Leakage resistance (electrode - housing) / dielectric strength	1 M $\Omega$ / 200 VDC	
	Coupling capacity (housing - power) Dielectric strength	50 nF 350 VAC	
	Coupling capacity (electrode - power) Dielectric strength	47 nF 350 VAC	
	Maximum load resistance for current output (at U = 24 V)	R <sub>max</sub> = 700 $\Omega$	
	Max. internal values (Explosion Proof)	U <sub>i</sub> = 30 VDC I <sub>i</sub> = 132 mA P <sub>i</sub> = 0.99 W C <sub>i</sub> = 35 nF L <sub>i</sub> = 10 $\mu$ H	
Cables LC values (Explosion Proof)	typic C < 150 pF/m typic L < 0.8 $\mu$ H/m		
<b>Materials</b>	Cable (with Cable Glands)	Standard Atmosphere	PVC 3 x 0.5 mm <sup>2</sup>
		Explosion Proof	2 x 0,75 mm <sup>2</sup>
	Weight without electrode or cable	cca 0.3 kg	
		cca 0.6 kg	
	Housing	All variants (Except Tri-clamp variants)	Stainless steel W.Nr. 1.4301 (AISI 304)
		For Tri-clamp variants	Stainless steel W.Nr. 1.4404 (AISI 316L)
	Rod Electrode	All Electrodes (Except E1, E5, and E7)	Stainless steel W.Nr. 1.4404 (AISI 316L)
	Rope Electrode (E9)	Stainless steel W.Nr. 1.4401 (AISI 316)	
	Reference Tube (E7 and E8)	Stainless steel W.Nr. 1.4301 (AISI 304)	
	Insulated Bushing	All Electrodes (Except E4 and E9)	PTFE
		For Electrode E9	PPS + GF40
	Electrode Coating	For Electrode E2, E4, E6, E8, and E10	FEP
		For Electrode E3	PFA
	Weight	Stainless steel W.Nr. 1.4404 (AISI 316L)	
	Weight for Rope Electrode	Stainless steel W.Nr. 1.4301 (AISI 304)	
Cable Gland	For Electrical Connection 1	Stainless steel W.Nr. 1.4571 (AISI 316 Ti) / NBR	
	For Electrical Connection 2	Plastic PA / NBR	
	For Electrical Connection 4	Nickel-plated brass / PA / rubber CR / NBR	
	For Electrical Connection 5 and 6	Plastic PA / NBR	
Connector M12	For Electrical Connection 3	Nickel-plated brass / PA	
Ending	Stainless steel W.Nr. 1.4301 (AISI 304)		

\* Verify chemical compatibility with the media. Upon agreement it is possible to select a different type of material.

# Technical Parameters Cont.

Technical Parameters			
<p><b>Environmental</b></p> <p>A device or part of it designed for zone 0 can also be used in zone 1 or 2.</p> <p>The device or its part intended for zone 1 can also be used in zone 2.</p> <p>The device or its part intended for zone 20 can also be used in zone 21 or 22.</p> <p>The device or its part intended for zone 21 can also be used in zone 22.</p>	Explosion Class	Hazard Performance "E" with <u>uncoated</u> rod or rope electrode	EN 60079-0 EN 60079-11 EN 60079-26 ATEX 0140X
		Intrinsically safe explosion-proof performance for use in hazardous areas (explosive gas atmospheres or explosive atmospheres with dust) <b>Ex II 1G Ex ia IIB T4...T2 Ga; Ex II 1D Ex ia IIIC T200 120°C ... T200 345°C Da</b> with intrinsically safe supply units, whole sensor zone 0 and 20.	EN 60079-0 EN 60079-11 EN 60079-26 ATEX 0140X
		Hazard Performance "E" with <u>coated</u> rod or rope electrode	EN 60079-0 EN 60079-11 EN 60079-26 ATEX 0140X
		Intrinsically safe explosion-proof performance for use in hazardous areas (explosive gas atmospheres) <b>Ex II 1G Ex ia IIB T4 ... T2 Ga;</b> with intrinsically safe supply units, whole sensor zone 0.	EN 60079-0 EN 60079-11 EN 60079-26 ATEX 0140X
		Hazard Performance "EH" with <u>uncoated</u> rod or rope electrode	EN 60079-0 EN 60079-11 EN 60079-26 ATEX 0140X
		Intrinsically safe high-temperature explosion-proof performance for use in hazardous areas (explosive gas atmospheres or explosive atmospheres with dust) <b>Ex II 1/2G Ex ia IIB T4...T2 Ga/Gb; Ex II 1/2D Ex ia IIIC T200 120 °C ... T200 345 °C / T 90 °C ... T 315 °C Da/Db</b> with intrinsically safe supply units, electrode part zone 0 and 20, head zone 1 and 21.	EN 60079-0 EN 60079-11 EN 60079-26 ATEX 0140X
		Hazard Performance "EH" with <u>coated</u> rod or rope electrode	EN 60079-0 EN 60079-11 EN 60079-26 ATEX 0140X
		Intrinsically safe high-temperature explosion-proof performance for use in hazardous areas (explosive gas atmospheres) <b>Ex II 1/2G Ex ia IIB T4 ... T2 Ga/Gb;</b> with intrinsically safe supply units, electrode part zone 0, head zone 1.	EN 60079-0 EN 60079-11 EN 60079-26 ATEX 0140X
		Hazard Performance "M"	EN 60079-0 EN 60079-11 EN 60079-26 ATEX 0140X
		Intrinsically safe explosion-proof performance for use in mines with the occurrence of methane or coal dust <b>Ex I M1 Ex ia I Ma</b> with intrinsically safe supply units.	EN 60079-0 EN 60079-11 EN 60079-26 ATEX 0140X
Hazard Performance "MH"	EN 60079-0 EN 60079-11 EN 60079-26 ATEX 0140X		
Intrinsically safe high-temperature explosion-proof performance for use in mines with the occurrence of methane or coal dust <b>Ex I M1 Ex ia I Ma</b> with intrinsically safe supply units.	EN 60079-0 EN 60079-11 EN 60079-26 ATEX 0140X		
Electrical Protection Class (All)	EN 33 2000-4-41 EN 55022 EN 61326-1 EN 61000-4-2 to -8		
Working Area Class (All)	EN IEC 60079-0 EN 60079-11 EN 60079-10-1 EN 60079-10-2		
Water Protection Class	IP67 (Electrical Connection 3) IP68 (Electrical Connections 1, 2, 5, 6)		
Ambient Temperature Range	-40°F ... +185°F (-40°C ... +85°C)		

Maximal Temperature				
Hazard Performance	Category			
SH and EH	1G, 1/2G	Temperature Class		Medium Temperature (t <sub>m</sub> )
		T4		239°F (115°C)
		T3		356°F (180°C)
		T2		518°F (270°C)
SH and EH	1D, 1/2D	Surface Temperature		
		Process Connection Place	Explosion Proof	T <sub>200</sub> =T <sub>m</sub> + 113°F (45°C)
			Explosion Proof at High Temperatures	T=T <sub>m</sub> + 59°F (15°C)
		Process Connection	Explosion Proof	T <sub>200</sub> =T <sub>m</sub> + 113°F (45°C)
			Explosion Proof at High Temperatures	T=T <sub>m</sub> + 59°F (15°C)
Electrode	T <sub>200</sub> =T <sub>m</sub> + 113°F (45 °C)			
M and MH	MI	Maximal Medium Temperature	275°F (135 °C)	

# Technical Parameters Cont.

Variant	Media Temperature	Process Temperature	Ambient Temperature	Maximum Operating Pressure for Process Temperature				
				≤ 86°F (30°C)	≤ 185°F (85°C)	≤ 248°F (120°C)	≤ 302°F (150°C)	≤ 392°F (200°C)
Standard Atmosphere E1 and E5	-40°F ... +572°F (-40°C ... +300°C)	-40°F ... +185°F (-40°C ... +85°C)	-40°F ... +185°F (-40°C ... +85°C)	725 PSI	362 PSI	-	-	-
Standard Atmosphere E2, E3, E6, E7, E8, and E10	-40°F ... +392°F (-40°C ... +200°C)	-40°F ... +185°F (-40°C ... +85°C)	-40°F ... +185°F (-40°C ... +85°C)	725 PSI	290 PSI	-	-	-
Standard Atmosphere E4	-40°F ... +392°F (-40°C ... +200°C)	-40°F ... +185°F (-40°C ... +85°C)	-40°F ... +185°F (-40°C ... +85°C)	1160 PSI	870 PSI	-	-	-
Standard Atmosphere E9	-40°F ... +482°F (-40°C ... +250°C)	-40°F ... +185°F (-40°C ... +85°C)	-40°F ... +185°F (-40°C ... +85°C)	14.5 PSI	14.5 PSI	-	-	-
Standard Atmosphere in High Temperature Environments E1 and E5	-40°F ... +572°F (-40°C ... +300°C)	-40°F ... +392°F (-40°C ... +200°C)	-40°F ... +185°F (-40°C ... +85°C)	725 PSI	362 PSI	217 PSI	145 PSI	72 PSI
Standard Atmosphere in High Temperature Environments E2, E3, E6, E7, E8, and E10	-40°F ... +392°F (-40°C ... +200°C)	-40°F ... +392°F (-40°C ... +200°C)	-40°F ... +185°F (-40°C ... +85°C)	725 PSI	290 PSI	217 PSI	145 PSI	14.5 PSI
Standard Atmosphere in High Temperature Environments E4	-40°F ... +392°F (-40°C ... +200°C)	-40°F ... +392°F (-40°C ... +200°C)	-40°F ... +185°F (-40°C ... +85°C)	1160 PSI	870 PSI	580 PSI	435 PSI	290 PSI
Standard Atmosphere in High Temperature Environments E9	-40°F ... +482°F (-40°C ... +250°C)	-40°F ... +392°F (-40°C ... +200°C)	-40°F ... +185°F (-40°C ... +85°C)	14.5 PSI	14.5 PSI	14.5 PSI	14.5 PSI	14.5 PSI
Explosive and Mining* Environments E1 and E5	-40°F ... +572°F (-40°C ... +300°C)	-40°F ... +167°F (-40°C ... +75°C)	-40°F ... +167°F (-40°C ... +75°C)	725 PSI	362 PSI	-	-	-
Explosive and Mining* Environments E2, E3, E6, E7, E8, and E10	-40°F ... +392°F (-40°C ... +200°C)	-40°F ... +167°F (-40°C ... +75°C)	-40°F ... +167°F (-40°C ... +75°C)	725 PSI	290 PSI	-	-	-
Explosive and Mining* Environments E4	-40°F ... +392°F (-40°C ... +200°C)	-40°F ... +167°F (-40°C ... +75°C)	-40°F ... +167°F (-40°C ... +75°C)	290 PSI	290 PSI	-	-	-
Explosive and Mining* Environments E9	-40°F ... +482°F (-40°C ... +250°C)	-40°F ... +167°F (-40°C ... +75°C)	-40°F ... +167°F (-40°C ... +75°C)	14.5 PSI	14.5 PSI	-	-	-
Explosive and Mining* in High Temperature Environments E1 and E5	-40°F ... +572°F (-40°C ... +300°C)	-40°F ... +392°F (-40°C ... +200°C)	-40°F ... +167°F (-40°C ... +75°C)	725 PSI	362 PSI	217 PSI	145 PSI	72 PSI
Explosive and Mining* in High Temperature Environments E2, E3, E6, E7, E8, and E10	-40°F ... +392°F (-40°C ... +200°C)	-40°F ... +392°F (-40°C ... +200°C)	-40°F ... +167°F (-40°C ... +75°C)	725 PSI	290 PSI	217 PSI	145 PSI	14.5 PSI
Explosive and Mining* in High Temperature Environments E4	-40°F ... +392°F (-40°C ... +200°C)	-40°F ... +392°F (-40°C ... +200°C)	-40°F ... +167°F (-40°C ... +75°C)	290 PSI	290 PSI	290 PSI	290 PSI	290 PSI
Explosive and Mining* in High Temperature Environments E9	-40°F ... +482°F (-40°C ... +250°C)	-40°F ... +392°F (-40°C ... +200°C)	-40°F ... +167°F (-40°C ... +75°C)	14.5 PSI	14.5 PSI	14.5 PSI	14.5 PSI	14.5 PSI
*Mining in Standard and High Temperature Environments	Maximum 302°F (150°C) on any surface where the coal-dust can form layers			-	-	-	-	-

Note: For the correct operation of the level transmitter, none of the provided temperature ranges may be exceeded (media, process, or ambient temperature). The above temperatures are visually explained in the Figure below.

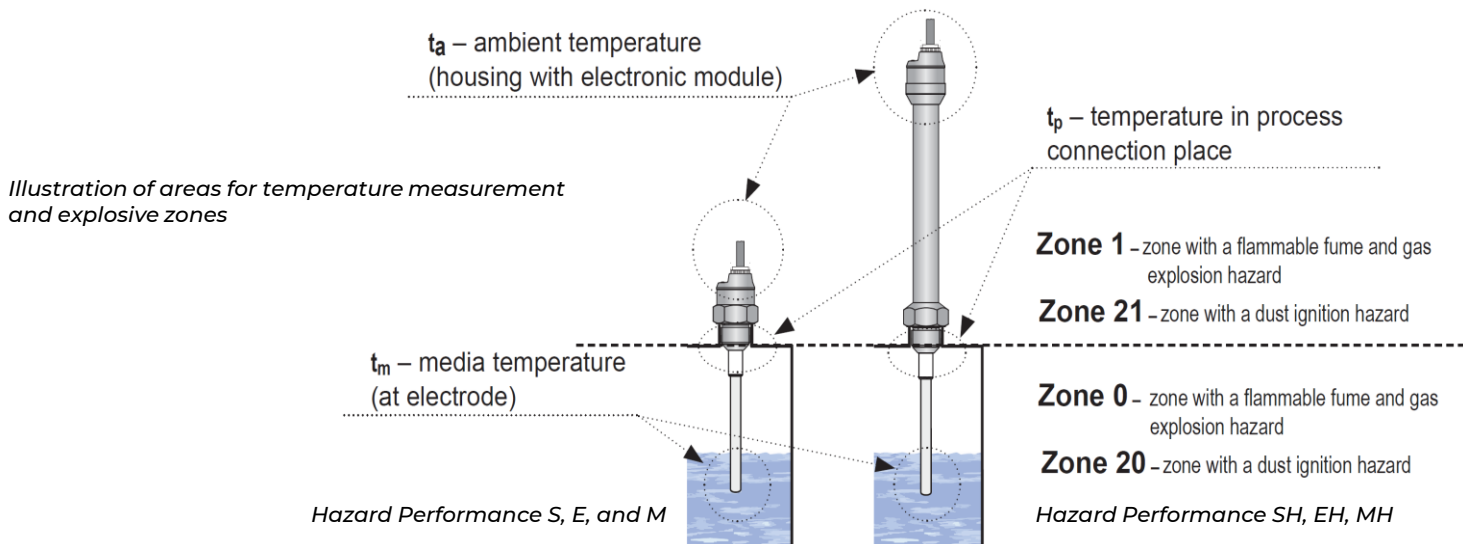

# Electrical Connection and Settings

## Electrical Connection

The positive pole of the supply voltage (+U) is connected to the brown wire (BN) or pin connector no.1, the negative pole (0 V) is connected to the blue wire (BU) or pin connector no. 3 and output voltage ( $U_{out}$ ) to the black wire (BK) or pin connector no. 4. Wiring diagrams are provided in the below figures.

Note: In case of strong ambient electromagnetic interference, paralleling of conductors with power distribution, or for the distribution to distance over 30 meters, we recommend using shielded cable.

The P107 with electrical connection 1, 2, 5, or 6 are connected to assessing units permanently connected by PVC cable.

The P107 with electrical connection 3 is connected to assessing units by means of a connector socket with compression cable (length 2 or 5 m), or by means of a connector socket without cable (see accessories), the connector is not part of the sensor. In this case the cable is connected to the inside pins of the socket according to figure 26. The recommended diameter of this cable is 4 to 6 mm (the recommended cross-sectional area is 0.25 to 0.5 mm<sup>2</sup>).

The length of the cable for all explosion and mining hazard performance variations must be selected with respect to the maximum permitted parameters (usually inductance and capacity) of the outside intrinsically safe circuit of supply units.

Fig. 23: Connection diagrams and interior view of connector of level meter P107 (variant output I)

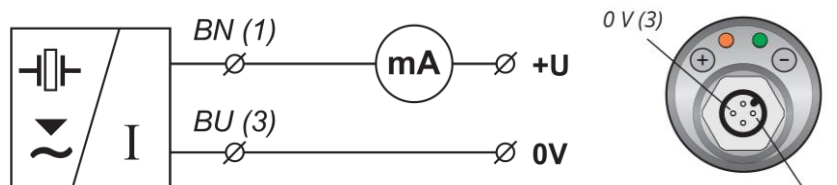

Fig. 25: Connection diagrams and interior view of connector of level meter P107 (variant output U)

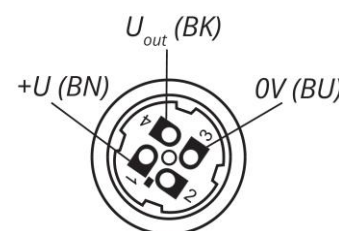
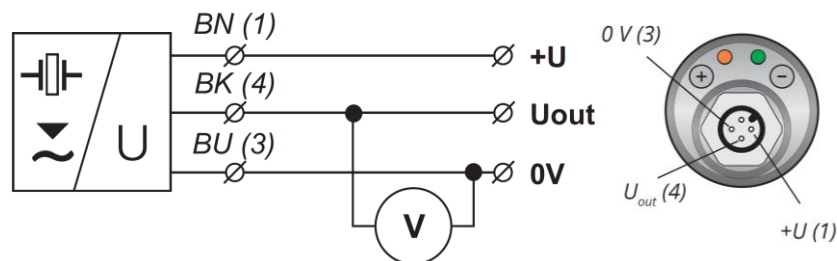

Fig. 24: Inside of the connector socket (variant "C")

**⚠** Electrical connection can only be made when de-energized!

The source of the power voltage must comprise of a stabilized safe low power source with galvanic separation. In the event that a switch mode power supply is used, it is essential that its construction effectively suppresses common mode interference on the secondary side. In the event that the switch-mode power supply is equipped with a PE safety terminal, it must be unconditionally grounded! Spark-safe devices like P107 with Hazard Performance E, EH, M, and MH must be powered from a spark-safe power source meeting the above-mentioned requirements.

**⚠** Due to the possible occurrence of an electrostatic charge on the non-conductive parts of the sensor, it is necessary to ground all sensors intended for use in environments with an explosion hazard (P107 with Hazard Performance E, EH, M, and MH). This can be performed by grounding electrically Conductive tanks or el. conductive tank lids, and in the case of el. non-conductive tanks using and grounding an auxiliary plate electrode.

In the event that the level switch is installed in an outdoor environment at a distance greater than 20 m from the outdoor switchboard, or from an enclosed building, it is necessary to supplement the electrical cable leading to the level switch with suitable overvoltage protection.

In the event of strong ambient electromagnetic interference, paralleling of conductors with power distribution, or for distribution to distances over 30 meters, we recommend using a shielded cable and grounding the shielding on the side of the power source.

## Settings

Settings of the measuring range are done by touching a magnetic pen to the pair of sensitive spot "-" and "+". Sensitive spot "-" used for input to the setting mode for setting the limit 4 mA (0 V) and decreasing the set current (voltage). Upon reaching the required current (voltage) waits for a permanently illuminated orange LED, and by applying the magnetic pen to the sensitive area "-", confirmation is performed of the set value. Sensitive area "+" is used for input to the setting mode for setting the limit setting 20 mA (10 V) and increasing the set current (voltage). Upon reaching the required current (voltage) it waits for a permanently illuminated orange LED, and by applying the magnetic pen to the sensitive area "+" confirmation is performed of the set value. The setting process is indicated by the orange LED "STATE". The green LED indicator "RUN" indicates correct function of level measurement. You can find more information in the instruction manual.

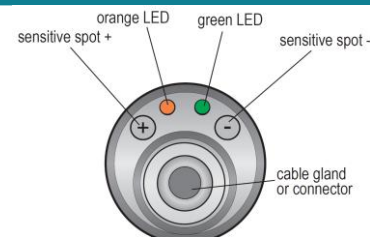
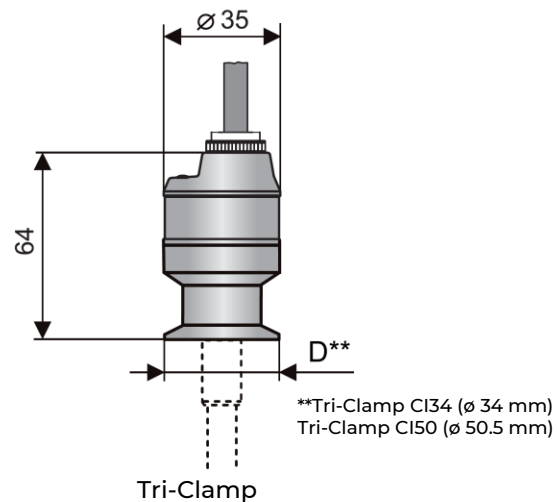
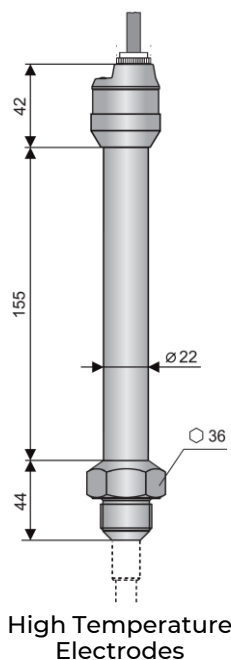
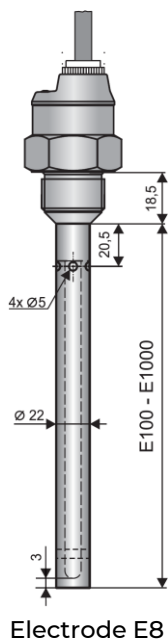
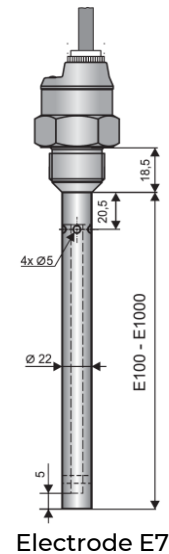
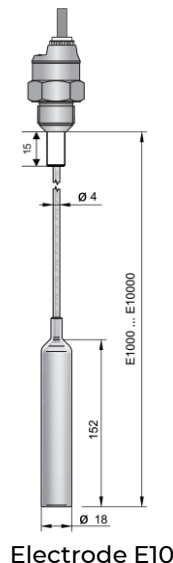
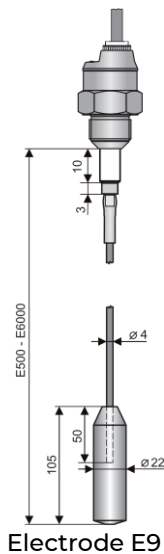
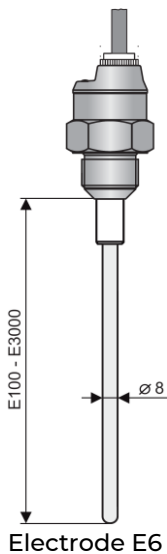
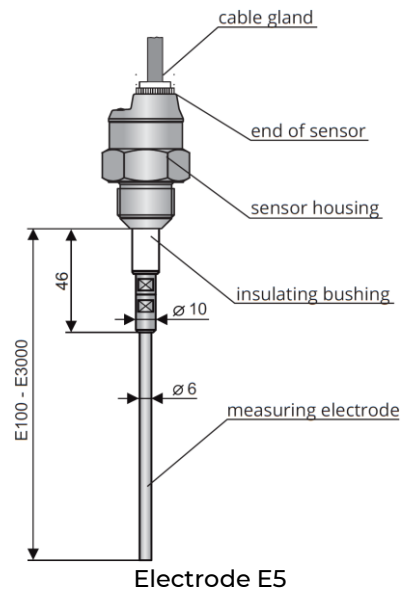
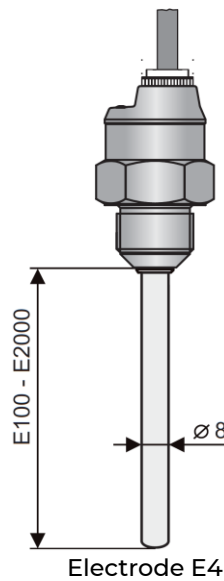
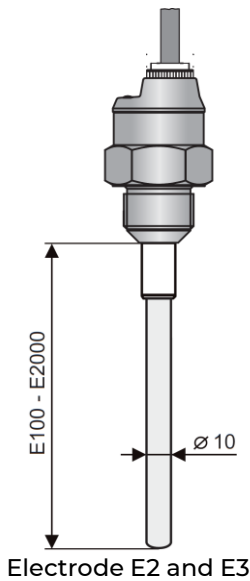
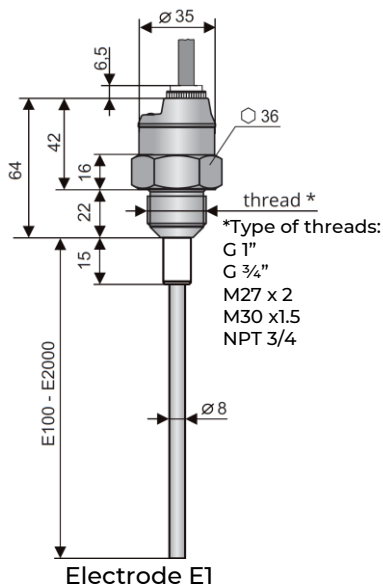
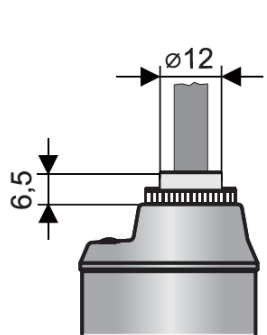

Fig. 26: Top view of level meter

# Dimensions



# Electrical Connection Dimensions



Variant "1" with short stainless steel gland

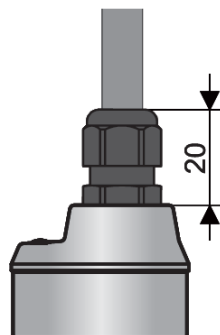

Variant "2" with plastic threaded cable gland

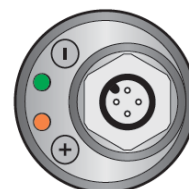
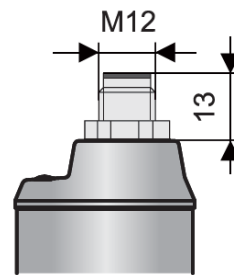

Variant "3" with connector M12

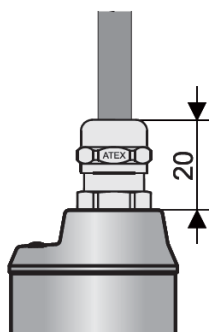

Variant "4" with metal dustproof terminal

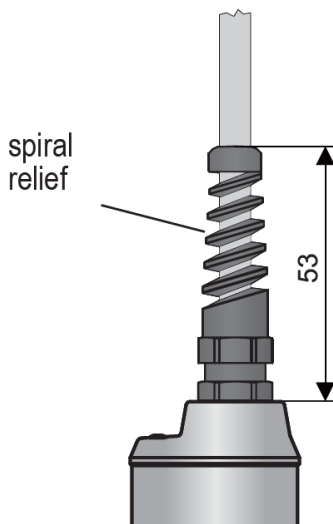

Variant "5" with plastic cable gland with spiral relief in case of increased mechanical wear on the cable

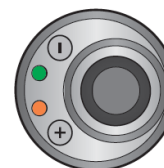
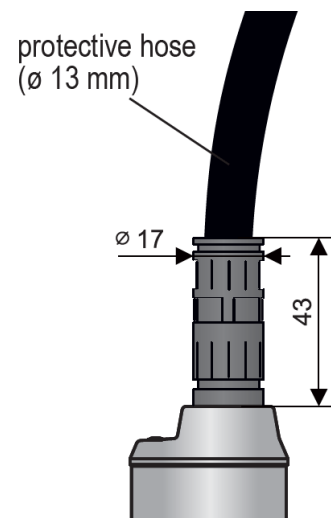

Variant "6" with cable gland for protected hoses for using in an outdoor area or in area with increased moisture.

# Installation Instructions & Status Indication

## Level Sensors

Level meters with coated electrode have protection cover at the end of electrode, which is necessary take down before mounting.

Level meters mount in vertical position to upper lid of tank or reservoir by welding flange, fixing nut or Clamp flange.

For mounting level meter to the metal tank or hopper, it is not necessary to ground the housing again.

In case of installation in concrete sumps or silos, it is appropriate to install the level meter onto a metallic auxiliary construction (console, lid, etc.) and then connect with metal constantly submerged object, eventually with steel armoring.

For level measurement of material in plastic and glass vessels by level meter without reference tube is necessary to connect grounding screw at housing with auxiliary electrode which is fixed in an appropriate manner to the outer casing of vessels (or at the inner wall). Material of auxiliary electrode must be selected with consideration for the working environment and properties of measured material.

### Variants with Rod Electrode

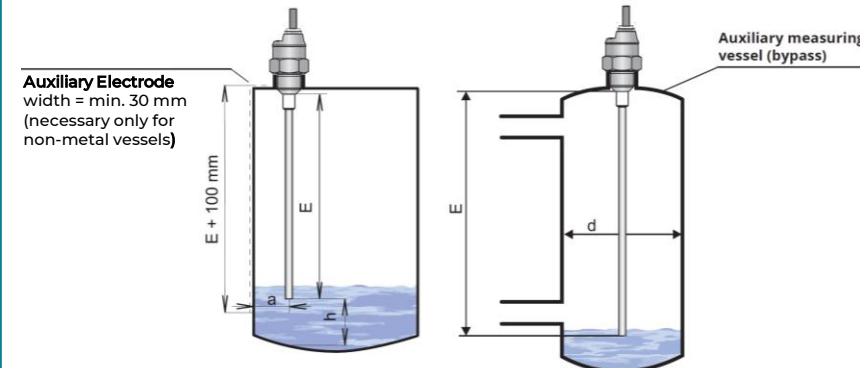

Fig. 19: Installation of level meters with rod electrode

### Electrode E1, E2, E3, E4, E5, and E6

### Variants with Reference Tube

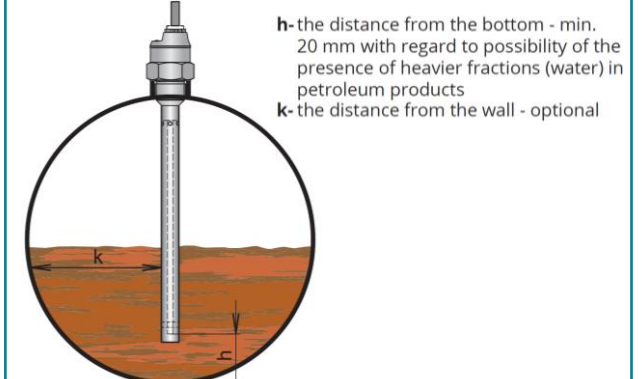

Fig. 21: Installation of level meter with reference tube

### Electrode E7 and E8

### Variants with Insulated Rope Electrode

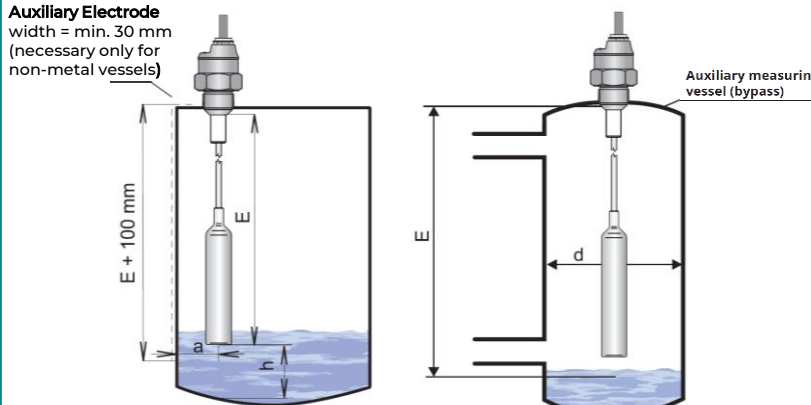

Fig. 20: Installation of level meters with insulated rope electrode

**E** - electrode length [mm] - choose so that the end of the electrode is immersed at least 20 mm below the lowest measured level  
**h** - distance from the bottom at least 20 mm

**a** - distance from the wall at least approx.  $E/20$   
**d** - diameter of the tubular auxiliary container - at least  $40 + E/20$  (smaller dimensions must be discussed)

### Electrode E10

### Variants with Rope Electrode

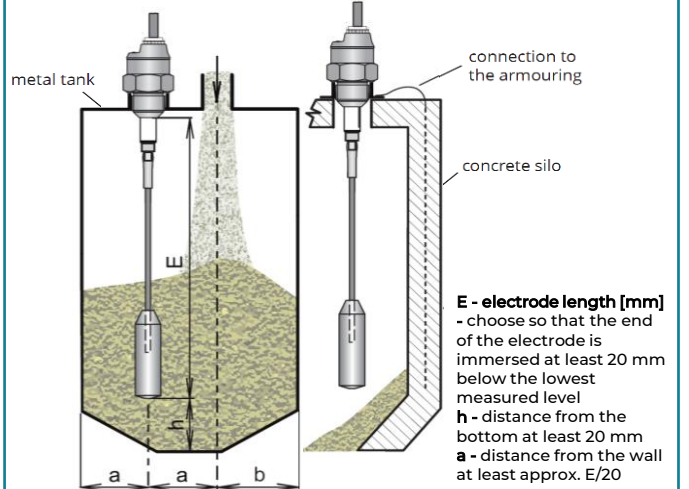

Fig. 22: Installation of level meter with rope electrode

**E** - electrode length [mm] - choose so that the end of the electrode is immersed at least 20 mm below the lowest measured level  
**h** - distance from the bottom at least 20 mm  
**a** - distance from the wall at least approx.  $E/20$

## Status Indication

LED Indicator	Color	Function
"RUN"	Green	<b>Measuring Function Indication</b> <b>Flashing</b> – correct function of measuring the level (repeats according to period of measuring approx. 0.5 s) <b>Dark</b> – incorrect installation or malfunction. LED is also not illuminated in limit setting mode. <b>Alternating flashing green and orange LED</b> – incorrectly set limits
"STATE"	Orange	<b>Settings Indication</b> <b>Slow Flashing</b> – indication of setting the lower limit <b>Rapid Flashing</b> – indication of setting the upper limit <b>Permanent Shine</b> – the level meter is prepared to confirm the limit setting by means of mag. pen <b>3x Short Flashes</b> – setting confirmation <b>Simultaneous shine of green and orange LED</b> – during touching the mag. pen, when the limit setting is confirmed

# Safety & Applications

## Safety, Protections, Compatibility and Explosion Proof

The level sensor is equipped with protection against electric shock on the electrode, reverse polarity, output current overload, short circuit and against current overload on output.

Protection against dangerous contact is provided by low safety voltage according to EN 33 2000- 4- 41. Electromagnetic compatibility is provided by conformity with standards EN 55022 / B, EN 61326-1, EN 61000-4-2 to -8.

Explosion proof variants of P107 are provided by conformity with standards EN 60079-0, EN 60079-11, EN 60079-26.

Explosion proof variants of P107 are verified ATEX 0140X.

A declaration of conformity was issued for this device in the wording of Act No. 90/2016 Coll., as amended. Supplied electrical equipment matches the requirements of valid European directives for safety and electromagnetic compatibility.

### Special Conditions for Safe Use of Explosion Proof Variants

Explosion proof variants are intended for connection to approved spark-safe power supply unit circuits (of insulating transducers) with galvanic separation. In the event that devices without galvanic separation are used (Zener barriers), it is necessary to balance the potential between the sensor, resp. level meter and the barrier grounding location.

The limit output parameters of spark-safe units (insulating transducers) must correspond to the limit input parameters of the level meter. When assessing spark-free safety of circuits, it is necessary to also take into consideration the parameters of the connected cable (namely its induction and capacity).

The variant for explosion proof hazard performance may be located in zone 0 or zone 20. With the variant for explosion proof hazard performance in high temperatures, it is only possible to located the electrode part in zone 0 and in zone 20, and then the head with the electronics in zone 1 or zone 21.

Ambient temperature:  $T_{amb} = -40^{\circ}\text{F} \dots +167^{\circ}\text{F} (-40^{\circ}\text{C} \dots +75^{\circ}\text{C})$

For the temperature of the measured material according to the variant configuration, see "Technical Parameters". The maximum temperature of the electrodes equals the temperature of the measured material.

## Applications of Individual Variants

### **P107 with Electrode E1**

Uncoated rod electrode for level measurement of bulk-solids and electrically non-conductive liquids.

### **P107 with Electrode E2**

Coated rod electrode (insulation FEP) for level measurement of water and other electrically conductive liquids. Can also be used for polluted liquids in metal tanks, concrete sumps, etc.

### **P107 with Electrode E3**

Coated rod electrode (insulation PFA) with enhanced resistance to permeation (diffusion) of vapors and gases. For level measurement of water and other electric conductive liquids in the food, pharmaceutical and chemical industries.

### **P107 with Electrode E4**

Coated rod electrode (insulation FEP) with higher pressure resistance at high temperature. Suitable for high temperature applications (hot steam).

### **P107 with Electrode E5**

Coated rope electrode with weight (FEP) , for electrically conductive and non-conductive liquids.

### **P107 with Electrode E6**

Coated rod electrode (FEP) for level measurement of water and other electrically conductive liquids. Can also be used for polluted liquids.

### **P107 with Electrode E7**

Uncoated rod electrode with reference tube (coaxial electrode) for accurate level measurement of unpolluted electrically non-conductive liquids.

### **P107 with Electrode E8**

Coated rod electrode with reference tube (coaxial electrode) for accurate level measurement of unpolluted electrically conductive liquids in plastic and glass tanks.

### **P107 with Electrode E9**

Uncoated rope electrode with weight for level measurement of bulk-solids.

### **P107 with Electrode E10**

Coated rope electrode with weight (FEP) , for electrically conductive and non-conductive liquids