

# M-LAS Series

## ▶ M-CON4-10-RFX-IR

### Electronic control unit

- For control of M-LAS-10-RFX-IR sensor (reflex laser light barrier)
- 2 digital outputs (Q and Qinv)
- Switching state indication by means of a bicolor-LED
- Potentiometer for sensitivity setting
- Switching frequency typ. 10 kHz
- Sturdy aluminum housing
- 4-pole M8 connector (connection to PLC)

In Proud Partnership with Sensor Instruments

**PAQUIN**  
SENSORS

For technical support, sales, & distribution within the USA & Canada

www.paquin.com | (800) 831-8217 | paquinsensors@paquin.com

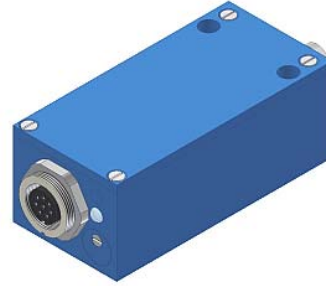

Design

### Product name:

#### M-CON4-10-RFX-IR

(for connection of M-LAS-10-RFX-IR laser light barrier)

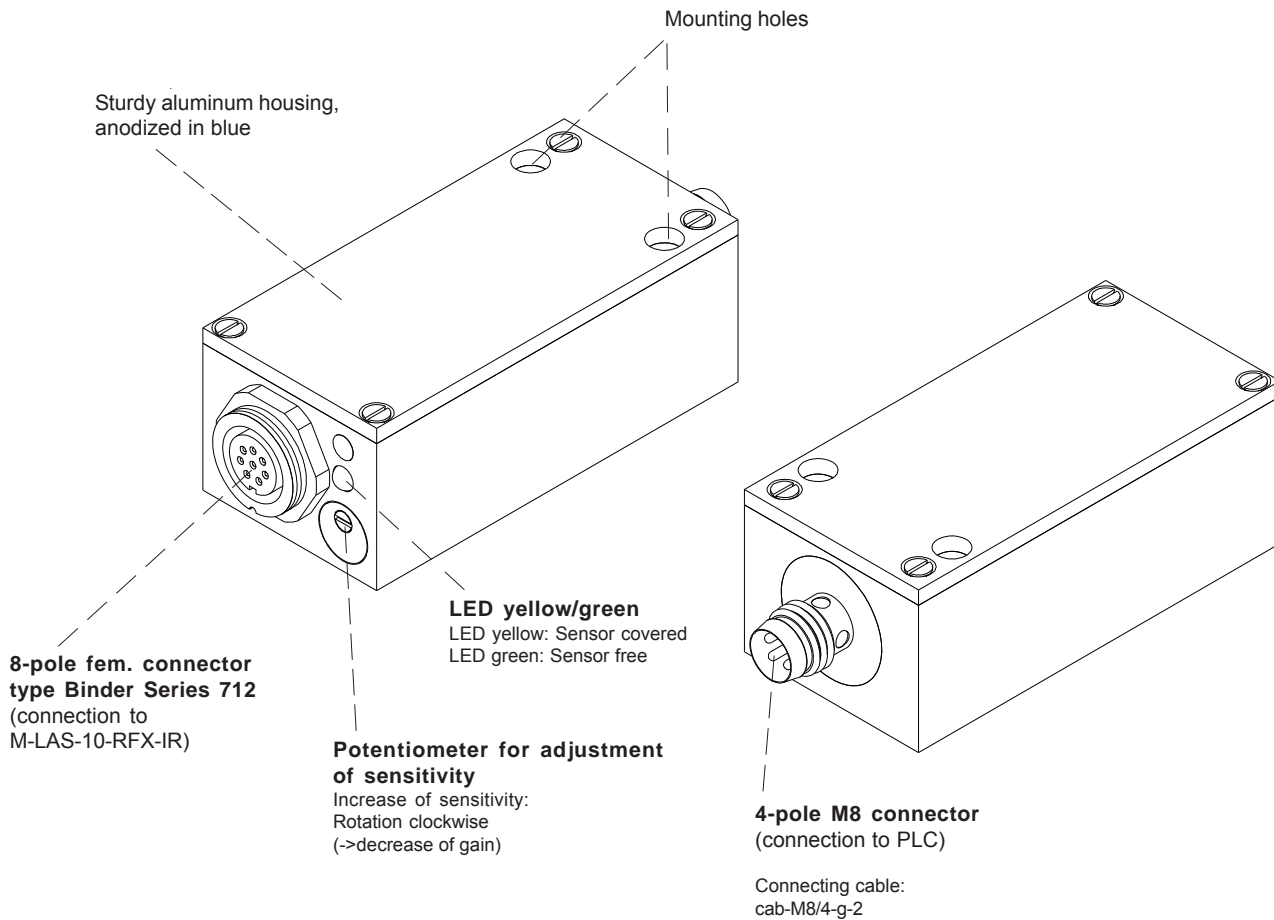



**Technical Data**

<b>Model</b>	<b>M-CON4-10-RFX-IR</b>
Voltage supply	+12VDC ... +32VDC Ripple 10% max.
Current consumption	with M-LAS sensor: typ. 80 mA
Operating temperature range	-20°C ... +60°C
Storage temperature range	-20°C ... +85°C
Measuring range	up to 800 mm $\mu$ m (depends on type of reflector)
Min. detectable object	starting from 20 $\mu$ m (depends on the measured object)
Housing	Aluminum, anodized in blue, dimensions: approx. 54 mm x 26 mm x 21 mm (without connector)
Enclosure rating	IP 64
Output DIGITAL	Pin 2: Q: PNP bright-switching (PNP n.c.) / NPN dark-switching (NPN n.o.) Pin 4: Qinv: NPN bright-switching (NPN n.c.) / PNP dark-switching (PNP n.o.)
Potentiometer for sensitivity setting (gain factor)	3-revolutions potentiometer integrated in the housing
Switching state indication	LED yellow/green (yellow = sensor covered, green = sensor free)
Type of connector	Connection to PLC: 4-pole M8 connector Connection to M-LAS sensor: 8-pole connector Binder Series 712
Modulation frequency	typ. 100 kHz
Switching frequency	typ. 10 kHz
Max. switching current	200 mA, overcurrent-protected
EMC test acc. to	DIN EN 60947-5-2

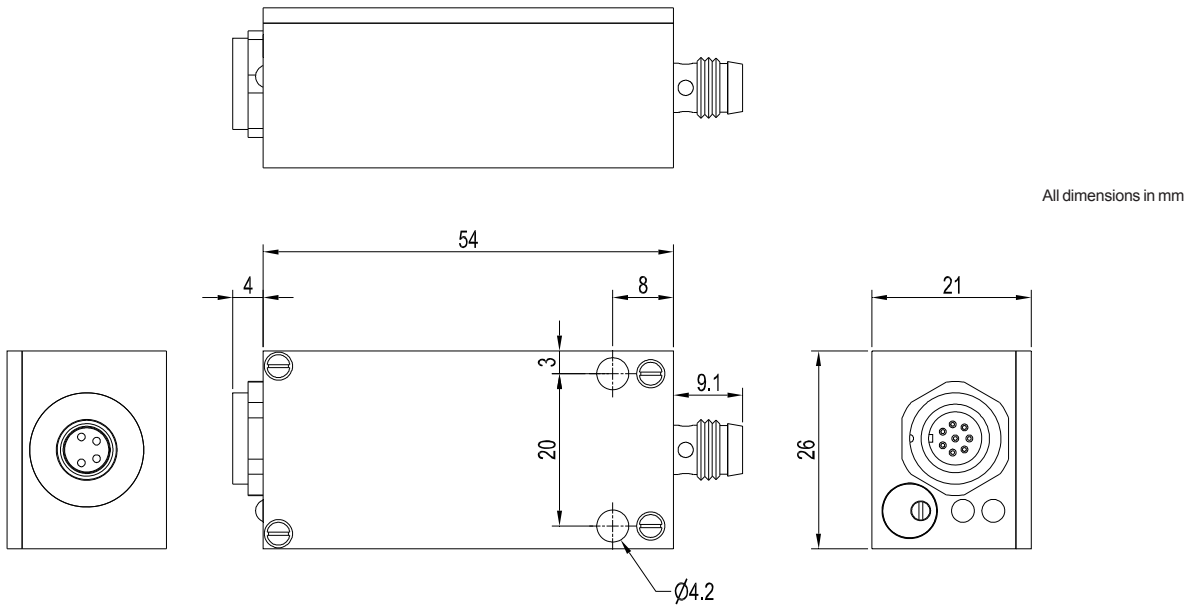
Dimensions

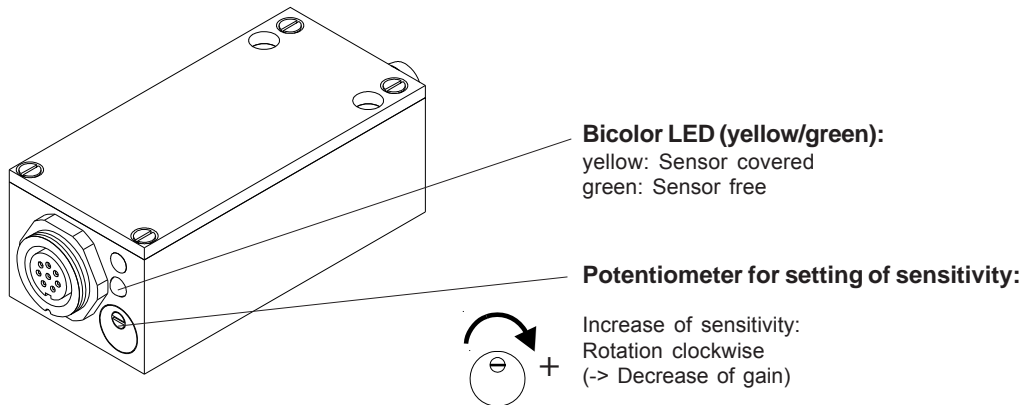

Setting



Connector Assignment

**8-pole fem. connector type Binder Series 712**  
(for connection of M-LAS-10-RFX-IR light barrier):

Pin-No.:	Assignment:
1	GND (0V)
2	+5V
3	n.c.
4	Output receiver (/AC)
5	n.c.
6	n.c.
7	Transmitter anode
8	Transmitter cathode

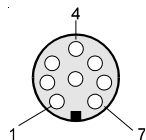

**4-pole M8 connector**  
(for connection to PLC):

Pin-No.:	Color:	Assignment:
1	brn	+Ub (+12VDC ... +30VDC)
2	wht	Output Q
3	blu	GND (0V)
4	blk	Output Qinv

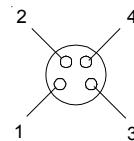

**Connecting cable to SPS:**  
cab-M8/4-g-2 (l = 2m)



Product Line

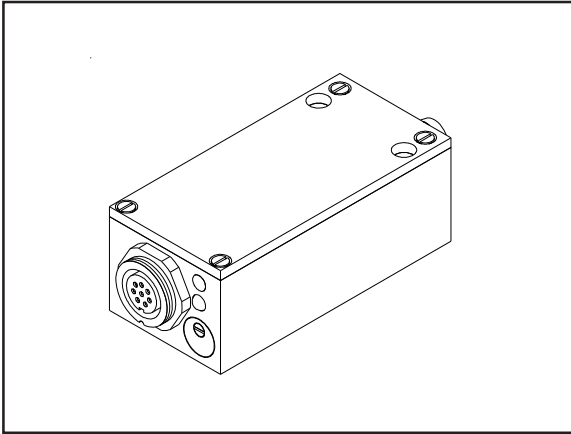

**M-CON4-10-RFX-IR**  
Electronic control unit

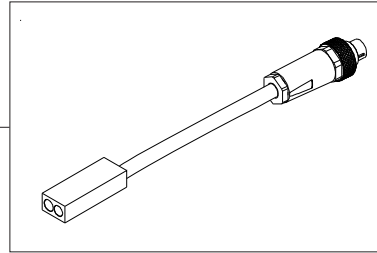

**M-LAS-10-RFX-IR**  
Reflex laser light barrier