

# L-LAS Series

► **L-LAS-TB-6-CON1**  
**L-LAS-TB/90-6x1-T, /-R**  
**L-LAS-TB/90-1x6-T, /-R**

- Line laser <0.39 mW, wave length 670 nm, laser class 1
- Visible laser line, typ. 6 mm x 1 mm
- Measuring range typ. 6.4 mm
- Resolution typ. 2 µm
- Transmitter/receiver distance max. 2 m
- Integrated interference filter
- CCD line detector with 512 pixel, 4096 subpixel (8-fold)
- External teach button and potentiometer for tolerance setting
- RS232 interface (USB or Ethernet adaptor is available)
- 2 digital inputs, 3 digital outputs
- 1 analog output 0 ... +10V (optionally 4 ... 20mA)
- Switching state indication via 4 LEDs (1x grn, 2x red, 1x yel)

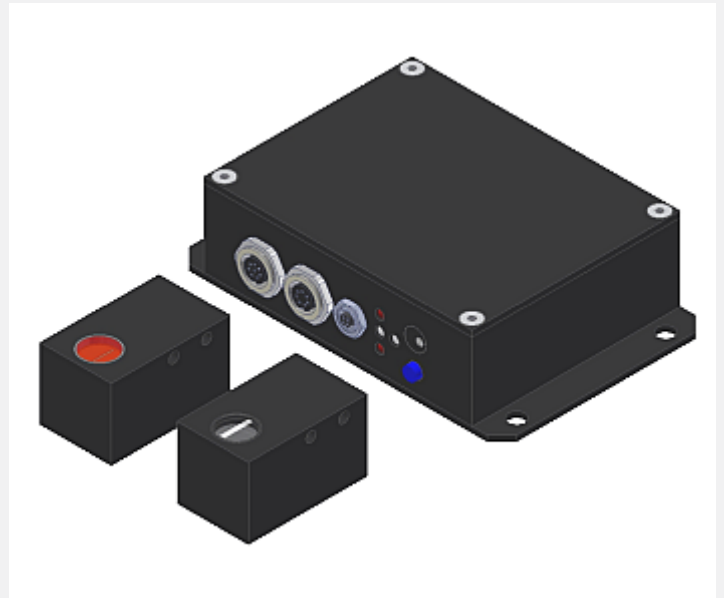

## Design

### Product name:

**L-LAS-TB-6-CON1** (electronic control unit, 0 ... +10V)  
**L-LAS-TB-6-CON1-4/20** (electronic control unit, 4... 20mA)  
(incl. Windows® PC software L-LAS-TB-Scope)

**L-LAS-TB/90-(AxB)\*-T** (transmitter)  
**L-LAS-TB/90-(AxB)\*-R** (receiver)

\***AxB** (position of the laser line):  
**6x1** (A=6mm, B=1mm)  
**1x6** (A=1mm, B=6mm)

Sturdy aluminum housing, anodized in black

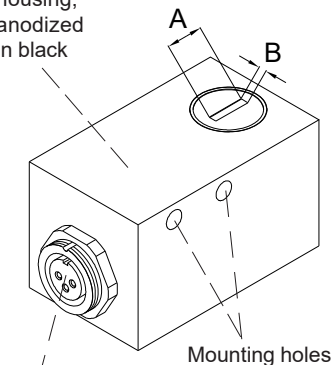

3-pole fem. connector Binder Series 712

Connecting cable: cab-las3-male

**L-LAS-TB/90-6x1-T** (transmitter)

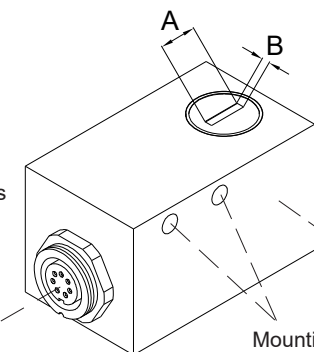

7-pole fem. connector Binder Series 712

Connecting cable: cab-las7-male

**L-LAS-TB-6-CON1** (electronic control unit)

Sturdy aluminum housing, anodized in black

8-pole fem. connector Binder Series 712 (connection to PLC)

Connecting cable: cab-las8/SPS

7-pole fem. connector Binder Series 712 (not necessary for single system)

4-pole fem. connector Binder Series 707 (RS232 interface)

Connecting cable: cab-las4/PC or cab-4/USB or cab-4/ETH

Mounting holes

Potentiometer for tolerance setting

**L-LAS-TB/90-6x1-R** (receiver)

LED display (cf. page 9)

TEACH button for norm value teaching

Sturdy aluminum housing, anodized in black





**Technical Data**

Model	L-LAS-TB-6-CON1 L-LAS-TB/90-(6)-T, L-LAS-TB/90-(6)-R	L-LAS-TB-6-CON1-4/20 L-LAS-TB/90-(6)-T, L-LAS-TB/90-(6)-R
Laser	Semi conductor laser, 670 nm, DC operation, <0.39 mW max. optical power, laser class 1 acc. to DIN EN 60825-1. The use of these laser transmitters therefore requires no additional protective measures.	
Max. distance transmitter/receiver	2 m	
Measuring range	typ. 6.4 mm	
Resolution	typ. 2 µm	
Reproducibility	typ. ± 2 µm	
Linearity	typ. 0,05% FSR (full scale range)	
Optical filter	Interference filter	
Analog output (ANA)	Voltage output 0 ... +10V	Current output 4 ... 20mA
Digital outputs (OUT0, OUT1, OUT2)	pnp bright-switching (pnp n.c.)/nnp dark-switching (nnp n.o.) or pnp dark-switching (pnp n.o.)/nnp bright-switching (nnp n.c.), adjustable under Windows®, 100 mA, short-circuit-proof	
Digital inputs (IN0, IN1)	IN0: External trigger, IN1: Teach/Reset (double function), input voltage +Ub/0V, with protective circuit	
Voltage supply	+24VDC (± 10%)	
Sensitivity setting	Adjustable by means of potentiometer TOL or under Windows® via PC	
Laser power correction	Dynamic/static mode adjustable under Windows® via PC	
Current consumption	typ. 200 mA	
Enclosure rating	Electronics: IP54, optics: IP67	
Operating temperature range	-10°C ... +50°C	
Storage temperature range	-20°C ... +85°C	
Housing material	Aluminum, anodized in black	
Housing dimensions (without connectors)	Control unit L-LAS-TB-6-CON1: LxWxH approx. 110 mm x 70 mm x 28 mm Transmitter and receiver frontend L-LAS-TB/90-(6)-T/-R: each LxWxH approx. 40 mm x 24 mm x 24 mm	
Type of connectors control unit L-LAS-TB-6-CON1	8-pole female connector type Binder 712 (PLC/Power), 4-pole female connector type Binder 707 (PC/RS232), 7-pole female connector type Binder 712 (not used with single system)	
Type of connector transmitter	Transmitter frontend L-LAS-TB/90-6x1-T or L-LAS-TB/90-1x6-T: 3-pole female connector Binder 712	
Type of connector receiver	Receiver frontend L-LAS-TB/90-6x1-R or L-LAS-TB/90-1x6-R: 7-pole female connector Binder 712	
Teach button	Teach button at the housing for set point value teaching	
LED display	LED red (+) : Measured value > upper tolerance threshold LED green : Measured value within tolerance window LED red (-) : Measured value < lower tolerance threshold LED yellow: For sensor adjustment (multifunctional LED)	
EMC test acc. to	DIN EN 60947-5-2	
Scan frequency	max. 650 Hz	
Max. switching current	100 mA, short-circuit-proof	
Interface	RS232, parameterisable under Windows®	
Connecting cables	Connection L-LAS-TB-6-CON1 to PC: cab-las4/PC or cab-4/USB or cab-4/ETH Connection L-LAS-TB-6-CON1 to PLC: cab-las8/SPS or cab-las8/SPS-w Connection L-LAS-TB/90-(6)-T to L-LAS-TB-6-CON1: cab-las3-male Connection L-LAS-TB/90-(6)-R to L-LAS-TB-6-CON1: cab-las7-male	
Output polarity	Bright-/dark-switching, adjustable under Windows®	



Dimensions

L-LAS-TB-6-CON1  
(electronic control unit)

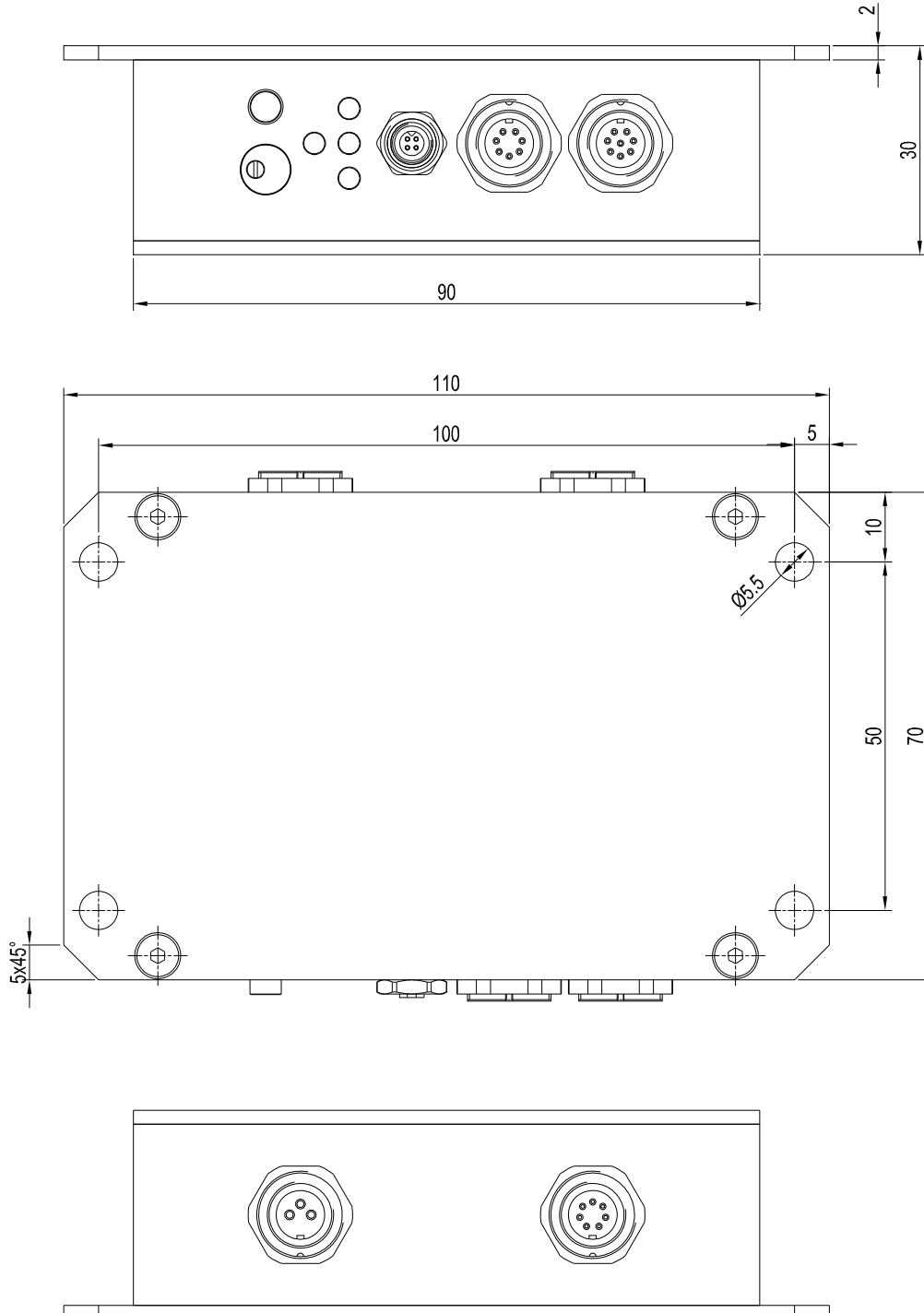

All dimensions in mm



Dimensions

L-LAS-TB/90-6x1-R or  
L-LAS-TB/90-1x6-R  
(receiver)

in case of model  
L-LAS-TB/90-6x1-R:  
Pixel 1  
(placed at the  
front side of  
the housing)

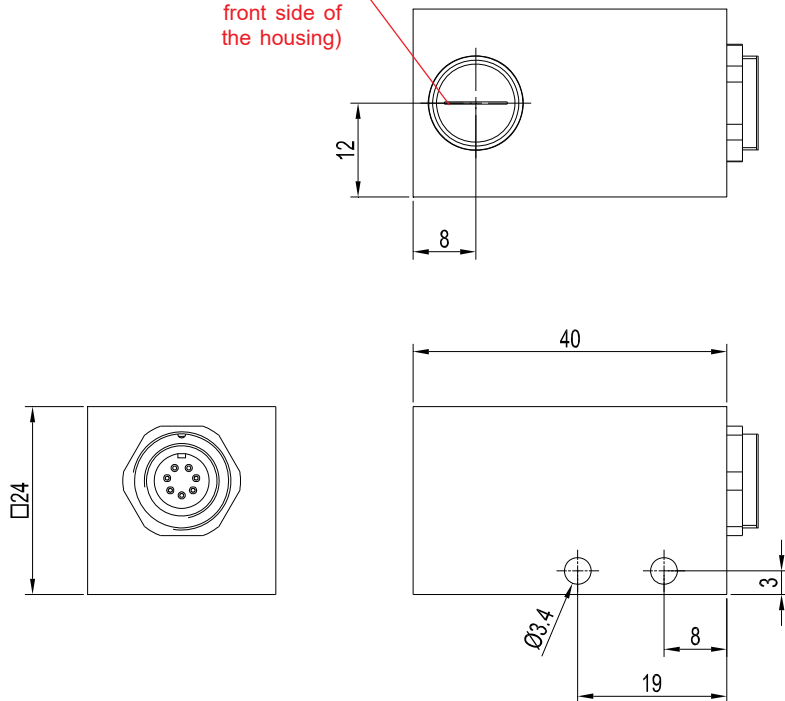

L-LAS-TB/90-6x1-T or  
L-LAS-TB/90-1x6-T  
(transmitter)

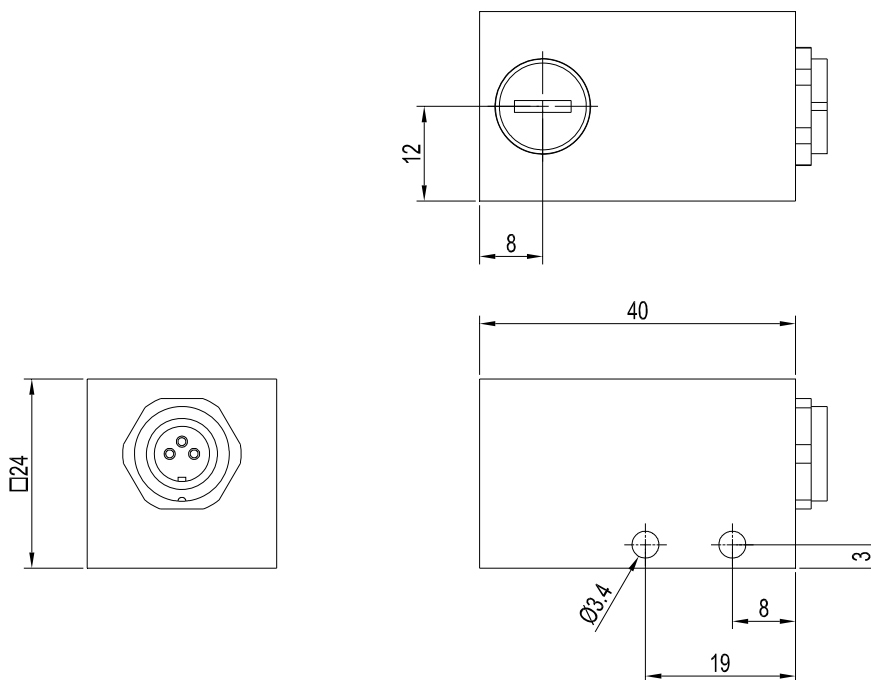

All dimensions in mm



**Connector Assignment**

**Connection L-LAS-TB-6-CON1 to PLC:  
8-pole fem. connector Binder Series 712**

Pin:	(Color of wire):	Assignment:
1	white	GND (0V)
2	brown	+24VDC (+Ub)
3	green	IN0 (EXT TRIGGER)
4	yellow	IN1 (TEACH / RESET)
5	grey	OUT0 (-)
6	pink or black	OUT1 (+)
7	blue	OUT2 (OK)
8	red	ANA (0 ... +10V)

**in case of version -4/20:  
ANA (4 ... 20mA)**

Connecting cable:  
cab-las8/SPS-(length) or  
cab-las8/SPS-w-(length) (angle type 90°)  
(standard length 2m)

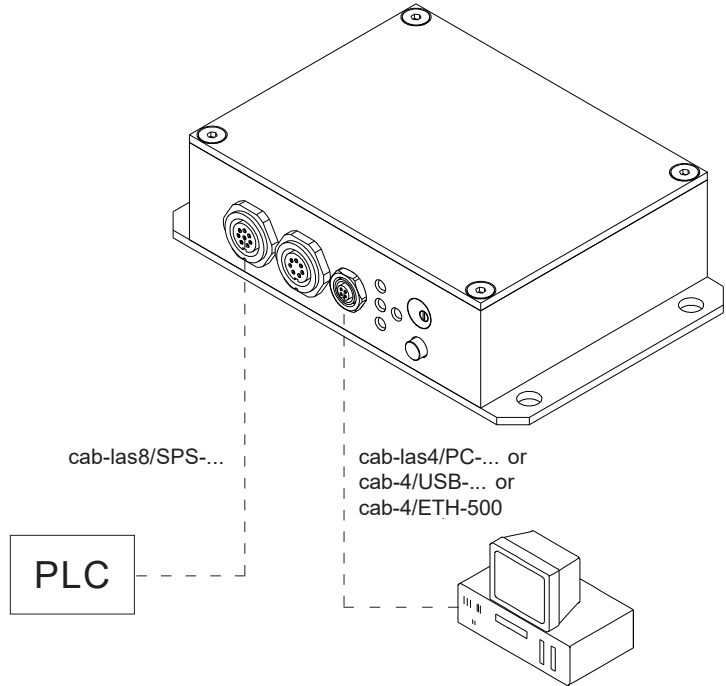

**Connection L-LAS-TB-6-CON1 to PC:  
4-pole fem. connector Binder Series 707**

Pin:	Assignment:
1	+24VDC (+Ub, OUT)
2	GND (0V)
3	RxD
4	TxD

**Connection via RS232 interface  
at the PC:**

Connecting cable:  
cab-las4/PC-(length)  
cab-las4/PC-w-(length) (angle type 90°)  
(standard length 2m)

**alternative:**

**Connection via USB interface  
at the PC:**

Connecting cable  
(incl. driver software):  
cab-4/USB-(length)  
cab-4/USB-w-(length) (angle type 90°)  
(standard length 2m)

**alternative:**

**Connection to local network  
via Ethernet bus:**

Adapter  
(incl. software „SensorFinder“):  
cab-4/ETH-500  
(standard length 0.5m)

**Optional:**

External CAT5 cable, e.g.  
cab-eth/M12D-RJ45-fix-(length)

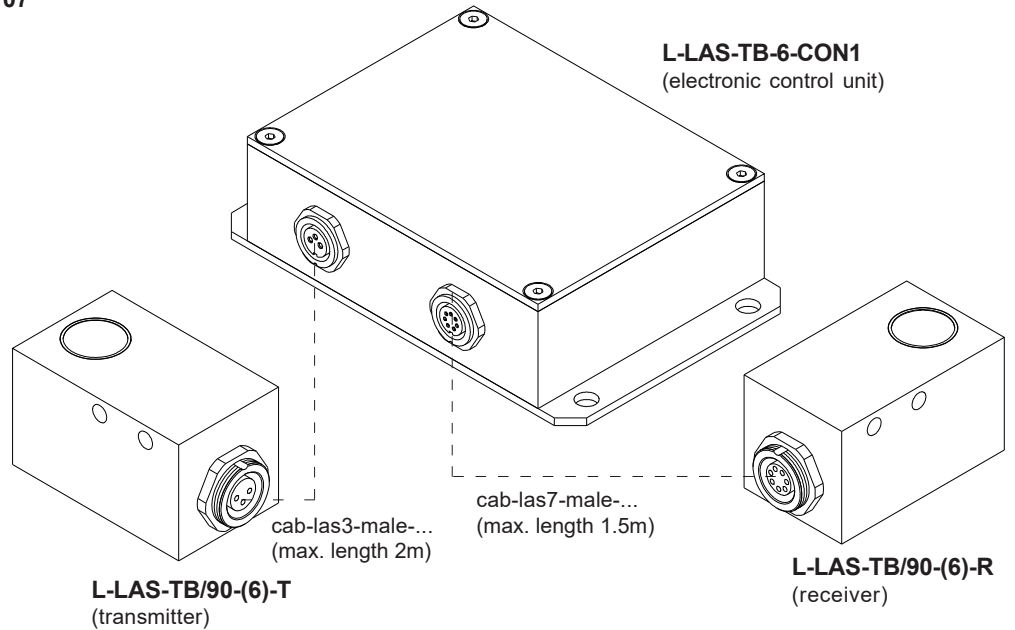

**Connection transmitter L-LAS-TB/90-(6)-T  
to L-LAS-TB-6-CON1:  
2x 3-pole fem. connectors Binder Series 712**

Pin:	Assignment:
1	+5VDC
2	GND (0V)
3	I-CONTROL (0V ... +5V)

Connecting cable:  
cab-las3-male-(length)  
cab-las3-male-w-(length) (angle type 90°)  
(standard length 2m)

**Connection receiver L-LAS-TB/90-(6)-R  
to L-LAS-TB-6-CON1:  
2x 7-pole fem. connectors Binder Series 712**

Pin:	Assignment:
1	GND (0V)
2	+6.9VDC
3	START
4	CLOCK
5	GAIN
6	GND (0V)
7	VIDEO

Connecting cable:  
cab-las7-male-(length)  
cab-las7-male-w-(length) (angle type 90°)  
(standard length 1m, max. length 1.5m)



Connecting Cables

Connection L-LAS-TB-6-CON1 to PLC:  
**cab-las8/SPS** oder  
**cab-las8/SPS-w** (angle type 90°)

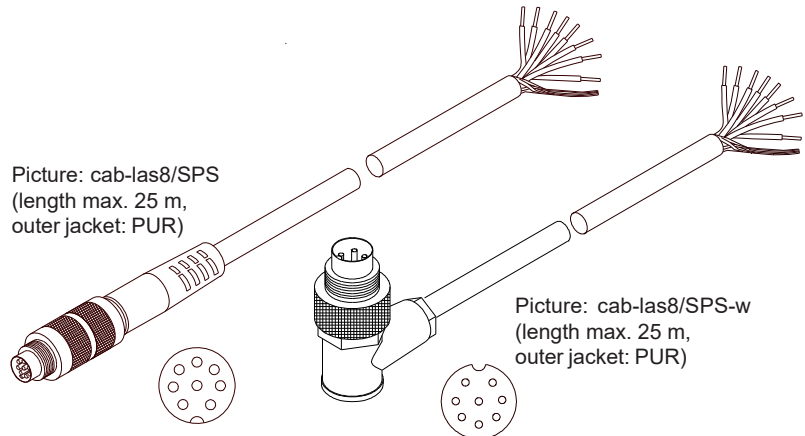

Connection L-LAS-TB-6-CON1 to PC:  
**cab-las4/PC** oder  
**cab-las4/PC-w** (angle type 90°) or  
**cab-4/USB** or  
**cab-4/USB-w** (angle type 90°) or  
**cab-4/ETH-500**

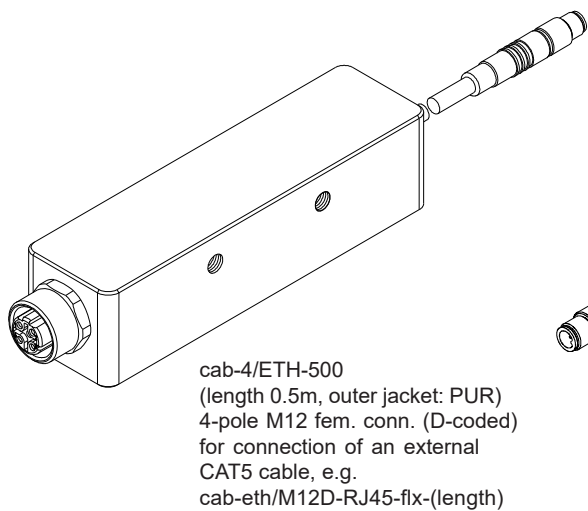
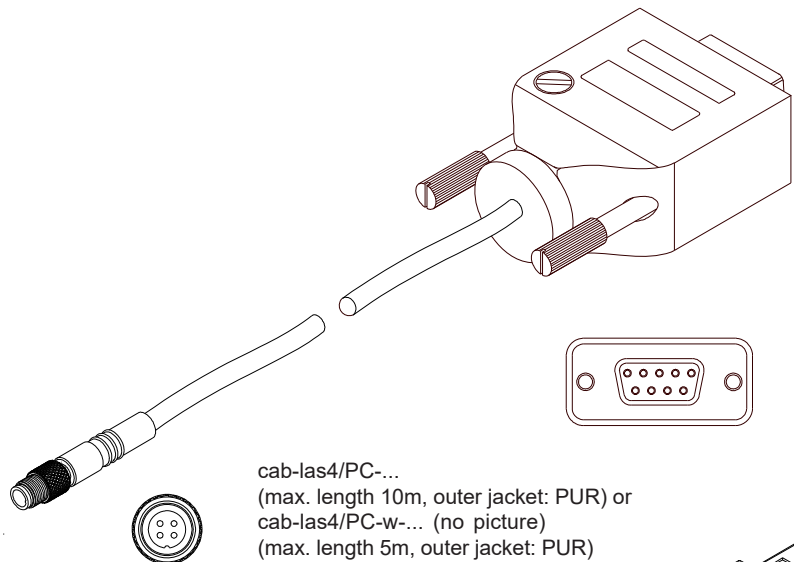

**cab-4/ETH-500**  
 (length 0.5m, outer jacket: PUR)  
 4-pole M12 fem. conn. (D-coded)  
 for connection of an external  
 CAT5 cable, e.g.  
 cab-eth/M12D-RJ45-flx-(length)

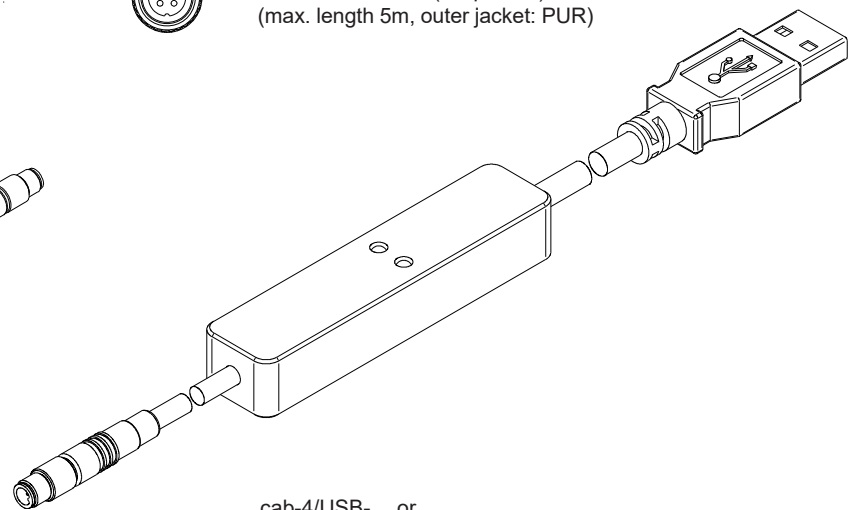

**cab-4/USB-...** or  
**cab-4/USB-w-...** (no picture)  
 (each max. length 5m, outer jacket: PUR)



Connecting Cables

Connection L-LAS-TB/90-(6)-T to L-LAS-TB-6-CON1:  
**cab-las3-male or**  
**cab-las3-male-w (angle type 90°)**

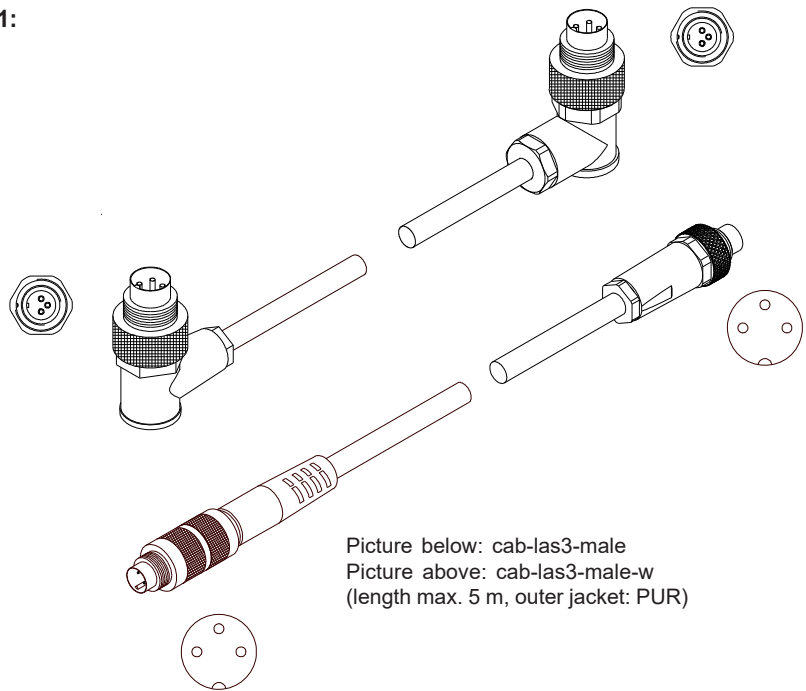

Picture below: cab-las3-male  
 Picture above: cab-las3-male-w  
 (length max. 5 m, outer jacket: PUR)

Connection L-LAS-TB/90-(6)-R to L-LAS-TB-6-CON1:  
**cab-las7-male or**  
**cab-las7-male-w (angle type 90°)**

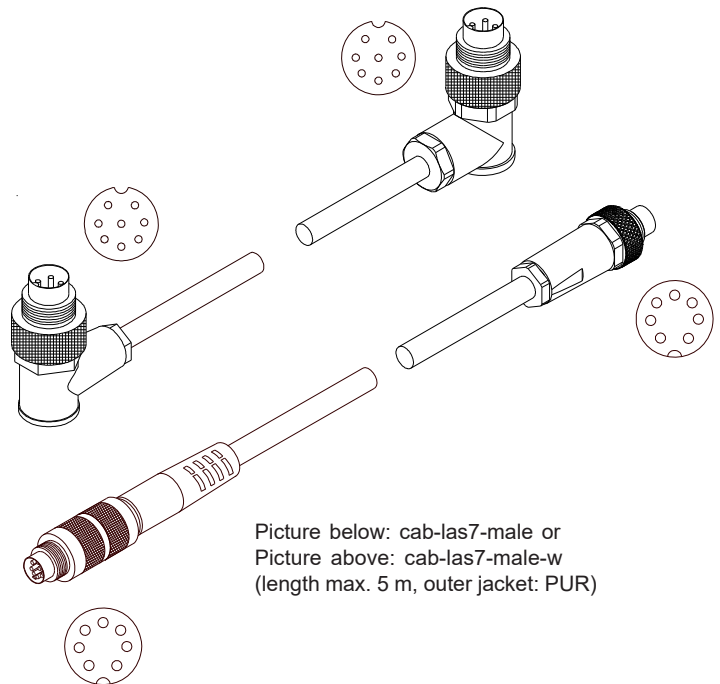

Picture below: cab-las7-male or  
 Picture above: cab-las7-male-w  
 (length max. 5 m, outer jacket: PUR)



LED Display

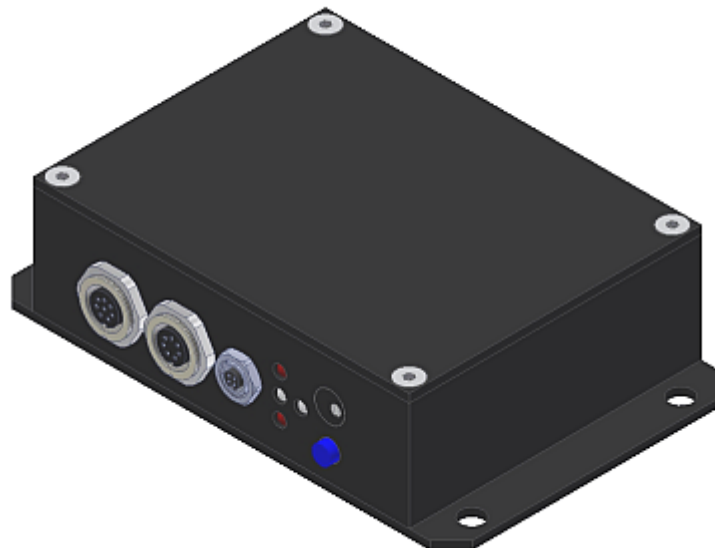
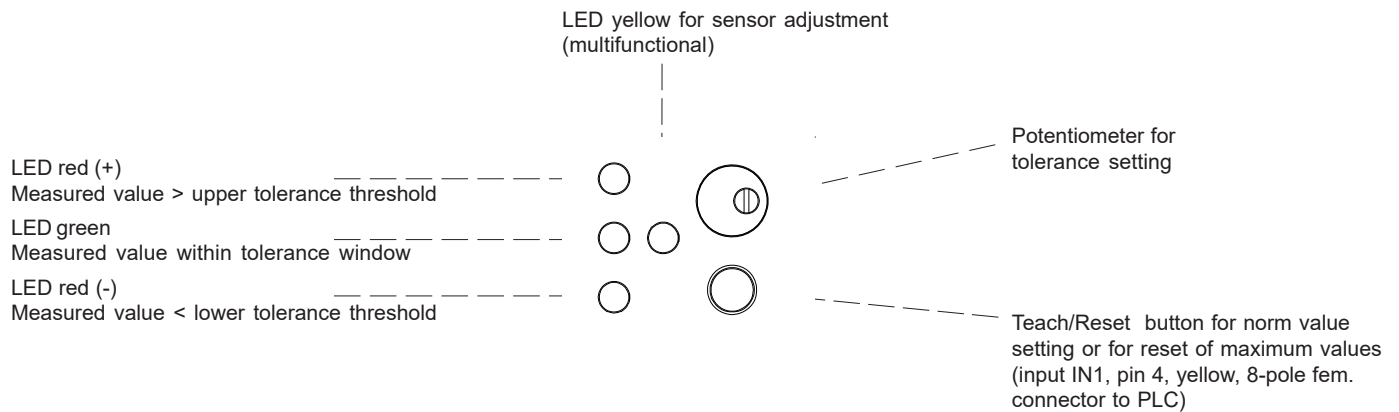

Laser Information

The laser line sensors of L-LAS-TB series comply with laser class 1 according to EN 60825-1. Under reasonably foreseeable conditions a class 1 laser is safe. The reasonably foreseeable conditions are kept during specified normal operation. The use of these laser transmitters therefore requires no additional protective measures.

The laser line sensors of L-LAS-TB series are supplied with an information label „CLASS 1 Laser Product“.



**Class 1 Laser Product**  
IEC 60825-1: 2014  
P<0.39 mW; λ=670 nm

COMPLIES WITH 21 CFR 1040.10 AND 1040.11 EXCEPT FOR CONFORMANCE WITH IEC 60825-1 ED. 3, AS DESCRIBED IN LASER NOTICE NO. 56, DATED MAY 8, 2019.





## Parameterization

### Windows® software L-LAS-TB-Scope:

The L-LAS-TB sensor can be easily parameterised with the Windows® user interface.

For this purpose the sensor is connected to the PC with the serial interface cable cab-las4/PC (or with the USB interface cable cab-4/USB or the Ethernet adapter cable cab-4/ETH). When parameterisation is finished, the PC can be disconnected again.

### Windows® user interface:

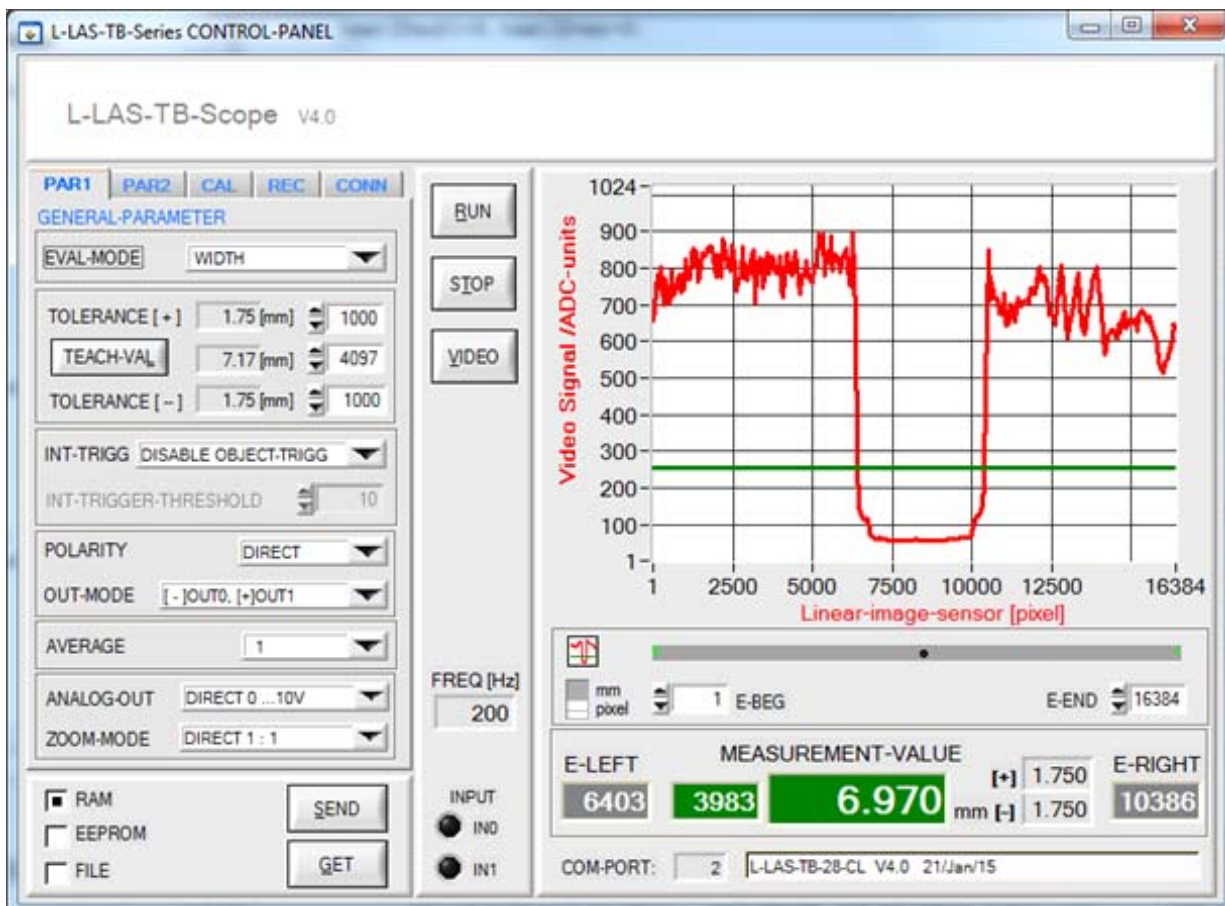

With the help of the L-LAS-TB-Scope software the following settings can be made at the sensor:

- Setting of laser power and type of automatic power correction
- Polarity of digital outputs
- Different evaluation modes
- Start of the teach process by software button
- Setting of tolerance ranges for monitoring the measured value

Furthermore, various numerical and graphical measured quantities can be visualized with the L-LAS-TB-Scope software. For example, the raw data of the CCD line sensor can be displayed graphically and numerically.



Application Examples

**Monitoring the cutting edge of foils**

The task is to check the cutting edge of foils during the cutting process, with an accuracy lying in the  $\mu\text{m}$  range.

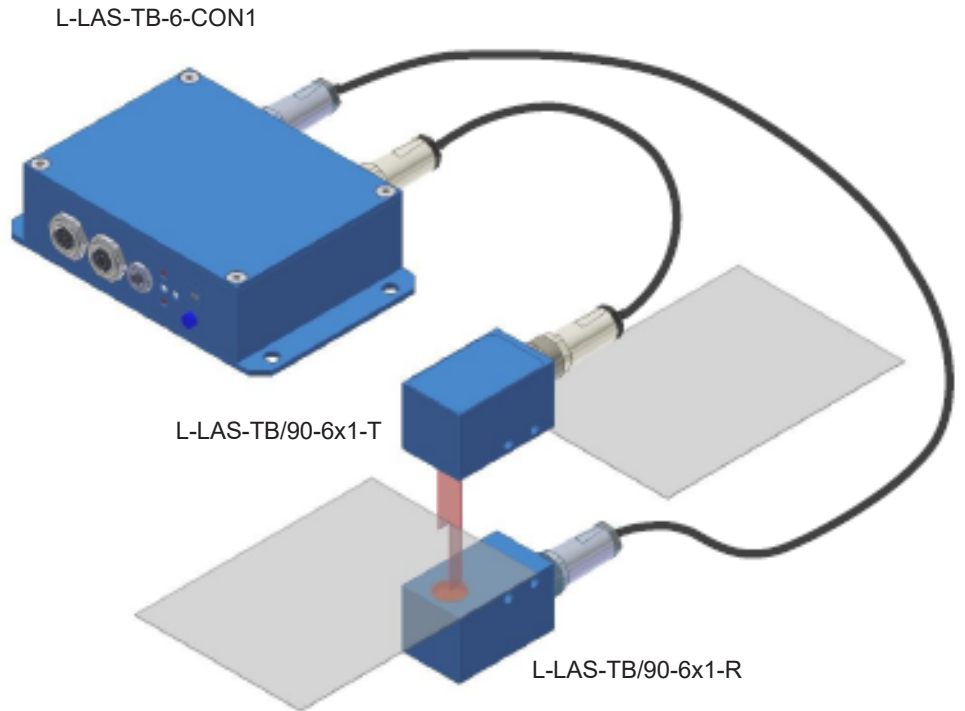

**Position checking of plastic foils directly before the welding process**

The position of the fed foil should be checked directly before two plastic foils are welded together.

