

In Proud Partnership with Sensor Instruments

**PAQUIN**  
SENSORS

For technical support, sales & distribution  
within the USA & Canada

# GLOSS Series

## ► GLOSS-20-20° GLOSS-20-20°-d...

- 20° gloss measurement (for high-gloss surfaces)
- Working distance 20 mm ± 10%
- Insensitive to outside light due to clocked white light
- Internal reference (thus optimum light power adjustment to the respective object surface)
- Teaching of up to 7 gloss degrees
- Parameterisable under Windows®
- RS232 interface (USB or Ethernet converter is available)
- Scratch-resistance glass cover of optics
- Compact and sturdy aluminum housing
- Transmitter power adjustable or controllable (STAT or DYN)
- Averaging can be activated (over up to approx. 32000 values)
- Digital input IN0 for teaching or optionally for scope function
- Digital input IN1 for the defined output of the analog signal
- 3 switching outputs (npn/-pnp-able, 100 mA, short circuit proof)
- 1 analog output (0...+10V or 4...20mA, selectable) parameterizable under Windows® proportional to gloss degree
- Calibration function (black glass) by means of calibration unit (optional)
- Offline unit available (optional)



### Design

#### Product name:

- GLOSS-20-20°** (without aperture)
- GLOSS-20-20°-d5.0** (aperture at transmitter side Ø 5.0mm)
- GLOSS-20-20°-d2.5** (aperture at transmitter side Ø 2.5mm)
- GLOSS-20-20°-d1.5** (aperture at transmitter side Ø 1.5mm)
- GLOSS-20-20°-d1.0** (aperture at transmitter side Ø 1.0mm)
- (incl. Windows® software GLOSS-Scope)

#### Accessories: (p. 7-8)

- GLOSS-20-20°-CAL** (Calibration unit)
- GLOSS-20-20°-OFL** (Offline unit)

4-pole fem. conn.  
Binder Series 707  
(RS232 interface)

Connecting cable:  
cab-las4/PC or  
cab-4/USB or  
cab-4/ETH

8-pole fem. conn.  
Binder Series 712  
(connection to PLC)

Connecting cable:  
cab-las8/SPS

Mounting  
possibilities  
(threaded M5)

Sturdy  
aluminum  
housing,  
anodized in  
black

Receiver  
optics

Trans-  
mitter  
optics



Sensor  Instruments

**PAQUIN**  
SENSORS



**Technical Data**

Type	GLOSS-20-20° / GLOSS-20-20°-d...		
Voltage supply	+24VDC (± 10%), protected against polarity reversal, overload protected		
Current consumption	typ. 100 mA		
Max. switching current	100 mA, short-circuit proof		
Interface	RS232, parameterisable under Windows®		
Digital inputs (2x)	digital input IN0: for teaching or optionally for scope function digital input IN1: for the defined output of the analog signal		
Digital outputs (3x)	OUT0 ... OUT2: Q <sub>inv</sub> or Q, (adjustable via PC): Q <sub>inv</sub> : npn bright-switching (npn n.c.) / pnp dark-switching (pnp n.o.) Q: pnp bright-switching (pnp n.c.) / npn dark-switching (nnp n.o.)		
Analog output (1x)	voltage output 0V...+10V or current output 4mA...20mA (can be switched under Windows®)		
Analog band width	max. 90 kHz (-3 dB)		
Tolerance range for digital outputs	parameterisable under Windows®		
Switching state indication	2 yellow LED visualize the physical state of the outputs OUT0 and OUT1		
Scan frequency	LED mode AC (depends on parameterization):		LED mode DC (depends on parameterization):
	Frequency [Hz]	Digital outputs	Analog output
	Max. 22 100	Off	Off
	Max. 22 000	On	Off
	Max. 20 300	Off	On
Max. 20 200	On	On	
Measurements were made with the smallest gain at the receiver (AMP1). At the highest gain (AMP8), the frequency is reduced by a factor of 5.		The frequency is independent of the gain set at the receiver.	
Switching frequency	max. 60 kHz		
Averaging	max. 32768 values, adjustable under Windows®		
Transmitter (light source)	white light LED		
Measurement range	20°: 0...2000 GU		
Reproducibility	0...100 GU: ± 0,2 GU 100...2000 GU: ± 0,2 %		
Working distance	typ. 20 mm ± 10 %		
Size of light spot	GLOSS-20-20° : at a working distand of 20 mm: typ. 10 mm x 11 mm (elliptical) GLOSS-20-20°-d5.0 : at a working distand of 20 mm: typ. 5 mm x 5.5 mm (elliptical) GLOSS-20-20°-d2.5 : at a working distand of 20 mm: typ. 2.5 mm x 2.7 mm (elliptical) GLOSS-20-20°-d1.5 : at a working distand of 20 mm: typ. 1.5 mm x 1.6 mm (elliptical) GLOSS-20-20°-d1.0 : at a working distand of 20 mm: typ. 1 mm x 1.1 mm (elliptical)		
Control mode for light source	AC operation (LED MODE-AC) or DC operation (LED MODE-DC), can be switched via PC software		
Transmitter power	parameterisable under Windows (STATIC or DYNAMIC)		
Optical filter	day light filter (KG2)		
Pulse lengthening	0 ... 100 ms (parameterisable under Windows®)		
Ambient light	up to 5000 Lux		
Housing dimensions	LxWxH approx. 160 mm x 50 mm x 40 mm		
Housing material	aluminum, anodized in black		
Enclosure rating	IP67		
Connecting cables	to PLC: cab-las8/SPS or cab-las8/SPS-w and cab-las4/SPS to PC/RS232 interface: cab-las5/PC or cab-las5/PC-w to PC/USB interface: cab-4/USB or cab-4/USB-w to PC/Ethernet interface: cab-4/ETH		
Type of connector	connection to PLC: 8-pole female connector Binder Series 712 connection to PC: 4-pole female connector Binder Series 707		
Operating temperature range	-20°C ... +55°C		
Storage temperature range	-20°C ... +85°C		
EMC test acc. to	DIN EN 60947-5-2		

Dimensions

GLOSS-20-20°  
GLOSS-20-20°-d...

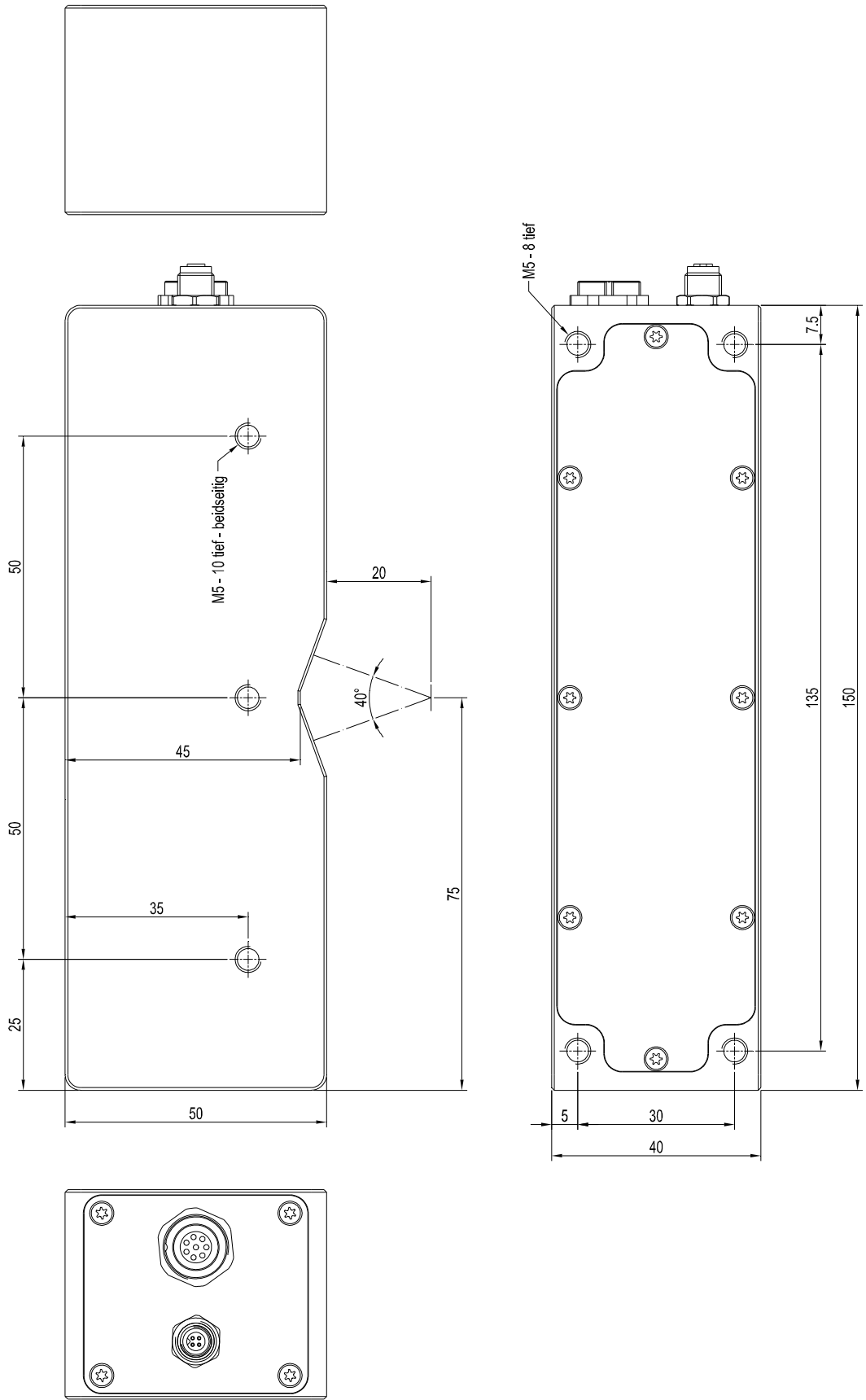

All dimensions in mm

Connector Assignment

Connection to PLC:

8-pole fem. connector Binder Series 712

Pin:	Color:	Assignment:
1	white	GND (0V)
2	brown	+24VDC (±10%)
3	green	IN0 (digital 0: 0 ... 1V, digital 1: +Ub - 10%)
4	yellow	IN1 (digital 0: 0 ... 1V, digital 1: +Ub - 10%)
5	grey	OUT0 (digital 0: Type 0 ... 1V, digital 1: Type +Ub - 10%)
6	pink or black	OUT1 (digital 0: Type 0 ... 1V, digital 1: Type +Ub - 10%)
7	blue	OUT2 (digital 0: Type 0 ... 1V, digital 1: Type +Ub - 10%)
8	red	ANALOG (0...+10V or 4 ... 20mA)

Connecting cable:  
 cab-las8/SPS-(length)  
 cab-las8/SPS-w-(length) (angle type, 90°)  
 (standard length 2m)

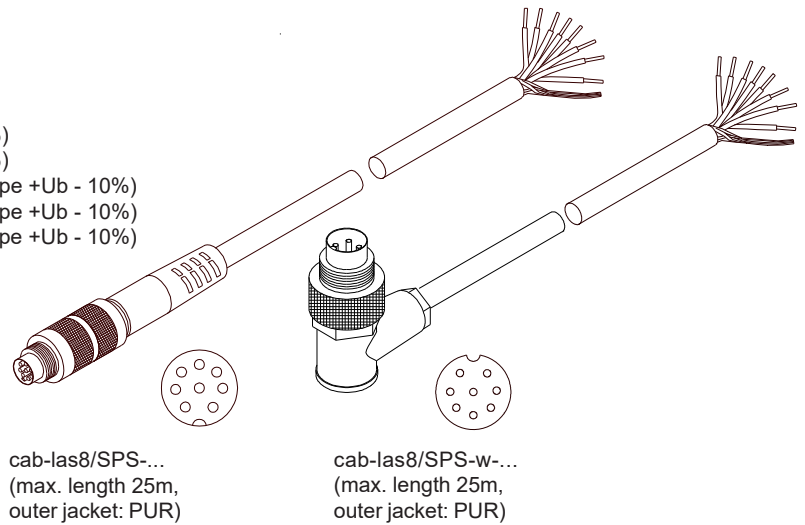

cab-las8/SPS-...  
 (max. length 25m,  
 outer jacket: PUR)

cab-las8/SPS-w-...  
 (max. length 25m,  
 outer jacket: PUR)

Connection to PC:

4-pol. fem. connector Binder Series 707

Pin:	Assignment:
1	+24VDC (+Ub, OUT)
2	GND (0V)
3	RxD
4	TxD

Connection via RS232 interface at the PC:

Connecting cable:  
 cab-las4/PC-(length)  
 cab-las4/PC-w-(length) (angle type 90°)  
 (standard length 2m)

alternative:

Connection via USB interface at the PC:

USB converter (incl. driver software):  
 cab-4/USB-(length)  
 cab-4/USB-w-(length) (angle type 90°)  
 (standard length 2m)

alternative:

Connection to local network via Ethernet bus:

Ethernet converter (incl. software „SensorFinder“):  
 cab-4/ETH-500 (incl. software „SensorFinder“)  
 (standard length 500mm)

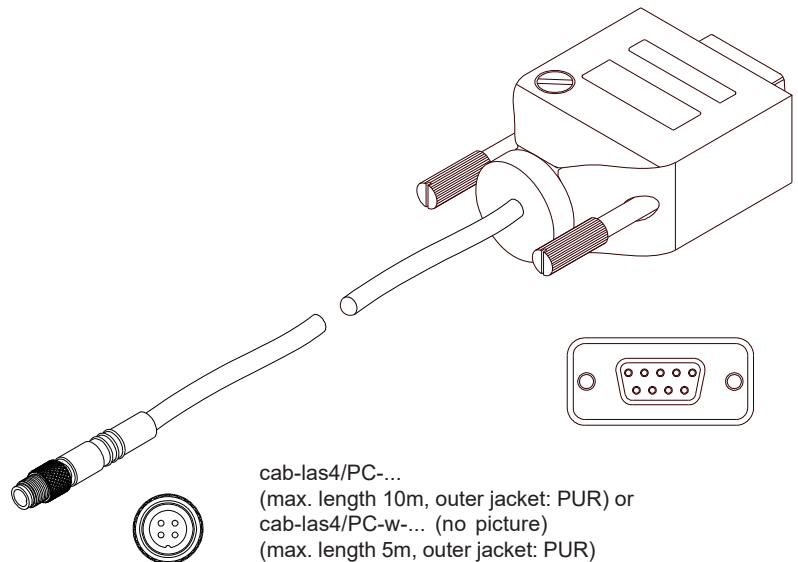

cab-las4/PC-...  
 (max. length 10m, outer jacket: PUR) or  
 cab-las4/PC-w-... (no picture)  
 (max. length 5m, outer jacket: PUR)

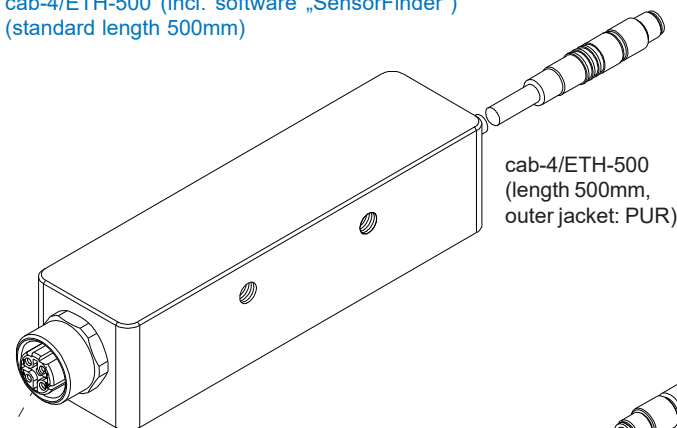

cab-4/ETH-500  
 (length 500mm,  
 outer jacket: PUR)

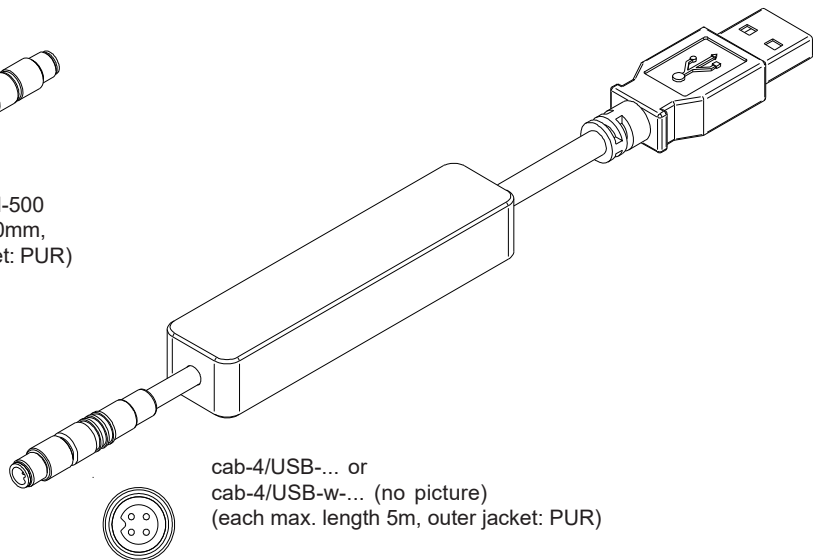

cab-4/USB-... or  
 cab-4/USB-w-... (no picture)  
 (each max. length 5m, outer jacket: PUR)

4-pole M12 fem. connector (D-coded) for  
 connection of an external CAT5 cable, e.g.  
 cab-eth/M12D-RJ45-flx-(length)  
 (available in length 2m, 5m, 10m, or 20m)

**Measuring Angles****For the gloss detection sensors of GLOSS Series different standard measuring angles are available:**

- 20°: For high-gloss surfaces.  
A 20° gloss sensor is used if gloss grades >70GU are to be determined.  
That is, if the gloss grade measured with a 60° gloss meter is >70GU, a 20° gloss sensor is used.
- 45°: TAPPI standard (paper industry) for glossy surfaces.
- 60°: For semi-gloss surfaces.  
A 60° gloss sensor is used if gloss grades >10GU to <70GU are to be determined.  
This variant is an "all-rounder". The 60° gloss sensor is therefore standard for most applications.
- 75°: TAPPI standard (paper industry) for matt surfaces.
- 85°: For matt surfaces.  
An 85° gloss sensor is used when gloss grades <10GU are to be determined.  
That is, if the gloss grade measured with a 60° gloss meter is <10GU, an 85° gloss sensor is used.

[GU = Gloss Unit]

**Measuring Principle****Measuring principle of the gloss detection sensor GLOSS-...:**

A white-light LED projects a white light spot onto the surface to be inspected. A part of the light that is directly reflected from the measuring object is directed onto a receiver by the receiver optics (the receiver optics is arranged at the same angle from the vertical as the transmitter optics). Furthermore, diffuse reflection is determined by means of an additional optics. Signal acquisition is performed with 12 bit.

The GLOSS sensor optionally can be „taught“ up to 7 gloss levels or norm vectors.  
The gloss level or the detected norm vector is provided at the digital outputs.  
In addition the gloss level also is provided in analog form from 0 to 10V or from 4mA to 20mA.

A digital input allows external „teaching“ of the sensor.  
As an alternative the sensor also can be triggered with the same input.  
An additional input allows the „freezing“ of the analog output signal upon a positive input edge.

The GLOSS sensor allows highly flexible signal acquisition. The sensor, for example, can be operated in alternating-light mode (AC mode), which means the sensor is not influenced by external light, or in constant-light mode (DC mode), which provides outstanding high-speed sensor operation. An OFF function deactivates the sensor's integrated light source. With the stepless adjustment of the integrated light source, the selectable gain of the receiver signal, and an INTEGRAL function the sensor can be adjusted to almost any surface.

The sensor must be calibrated for gloss level detection. For this purpose a reference surface is required which by definition has a gloss level of 100GU (Gloss Units). Calibration then is performed with the PC software. The sensor also can be calibrated to foreign systems, which can be optionally activated in the PC software.

The GLOSS series sensors are factory calibrated. When establishing the connection, the date of the next calibration is displayed in the status window in the CONNECT tab. For continuously accurate measurement results, we recommend having the calibration renewed every 18 months and sending in the sensors for calibration.

Parameters and measurement values can be exchanged between PC and sensor either through RS232 or Ethernet (using an Ethernet converter). Through the interface all the parameters can be stored in the non-volatile EEPROM of the sensor.

The PC software facilitates the parameterisation, diagnostics, and adjustment of the sensor system (oscilloscope function). The software furthermore provides a data recorder function that automatically records data and stores them on the hard disk of the PC.

GLOSS sensors are temperature-compensated over a range of 0°C to 80°C.

Possible firmware updates can be easily performed through the RS232 interface, even with the sensor system in installed condition.

When parameterisation is finished, the color sensor continues to operate with the current parameters in STAND-ALONE mode without a PC.

## Parameterization

### Windows® user interface:

(The current software version is available for download on our website.)

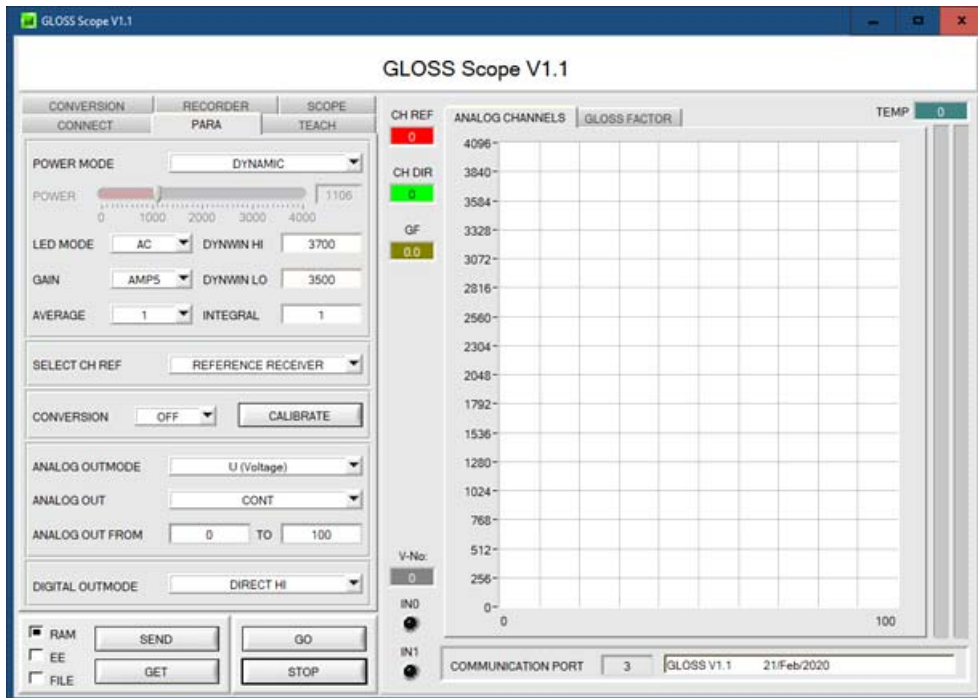

The gloss sensor is parameterized under Windows® with the GLOSS-Scope software. The Windows® user interface facilitates the teach-in process at the sensor and supports the operator in the task of adjustment and commissioning of the sensor.

The software provides various display elements and a graphic window for the visualisation of all the data that are important for parameterisation.

In the CONVERSION tab a certain conversion value can be assigned to the gloss factor GF signal.

The GLOSS-Scope software features a data recorder (RECORDER tab).

The SCOPE tab visualizes an oscilloscope.

## Firmware Update

### Firmware update by means of the software „FirmwareLoader“:

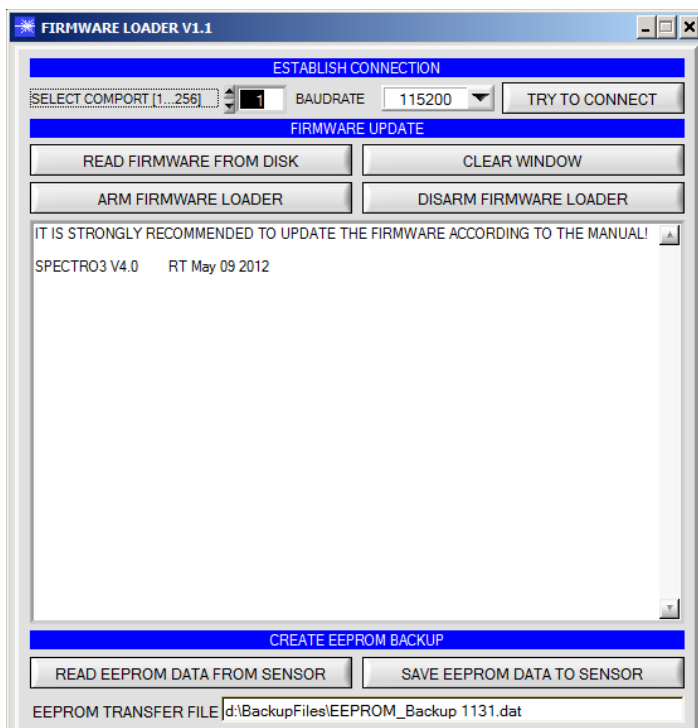

The software „Firmware Loader“ allows the user to perform an automatic firmware update. The update will be carried out through the RS232 interface.

An initialisation file (xxx.ini) and a firmware file (xxx.elf.S) are required for performing a firmware update. These files can be obtained from your supplier. In some cases an additional firmware file for the program memory (xxx.elf.p.S) is also needed, and this file will be automatically provided together with the other two files.





Calibration Unit

**GLOSS-20-20°-CAL**  
(Calibration unit, optional)

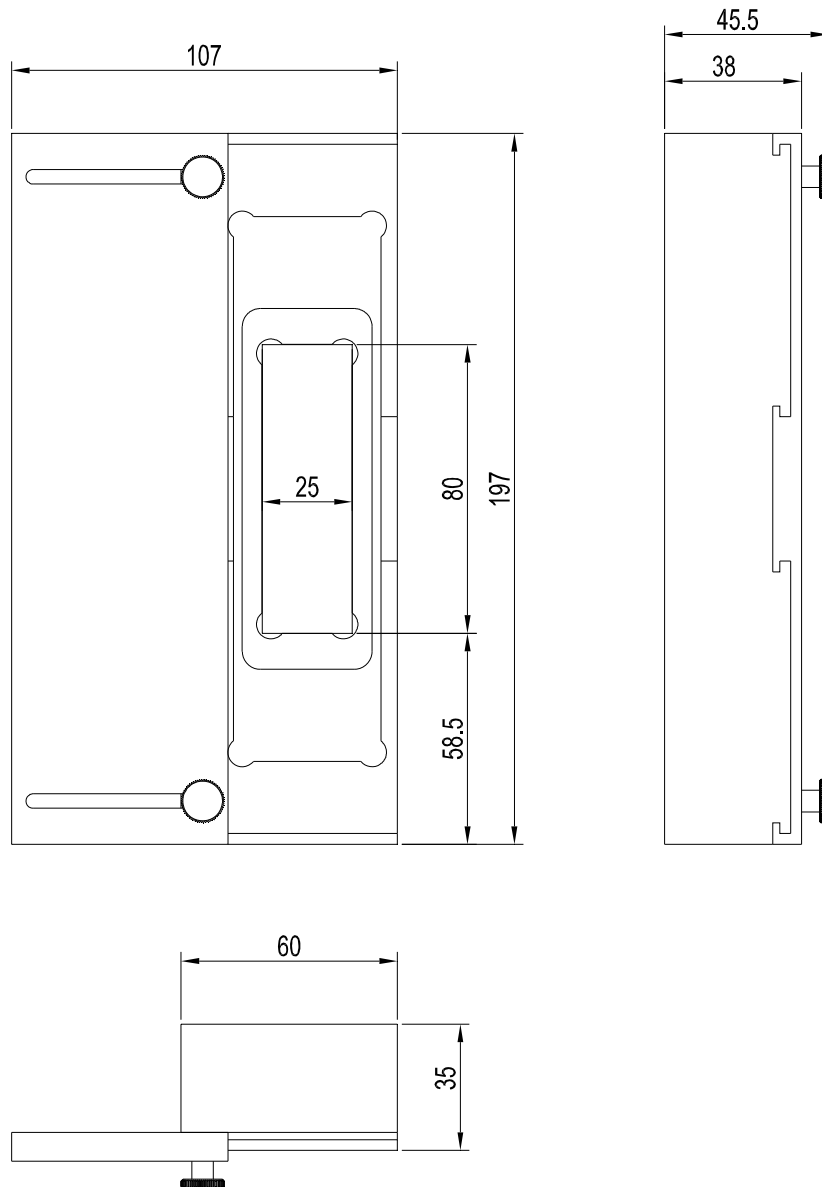
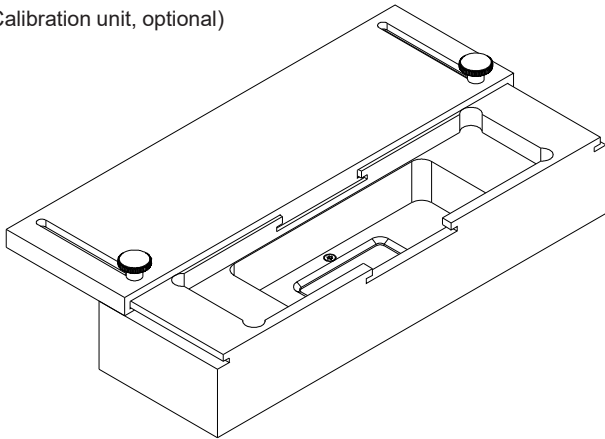

All dimensions in mm



Offline Unit

**GLOSS-20-20°-OFL**

(Offline unit / spacer, optional)

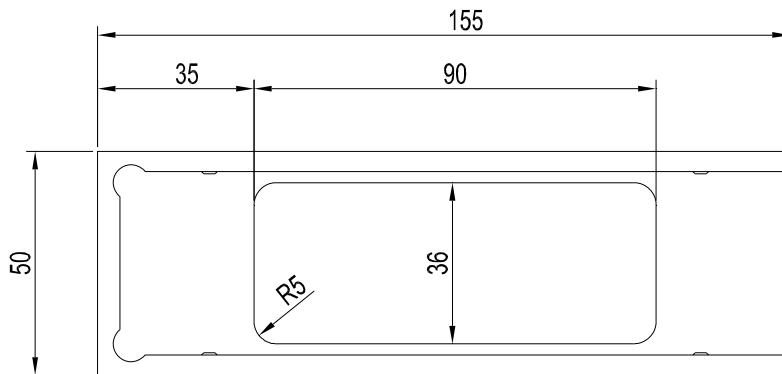
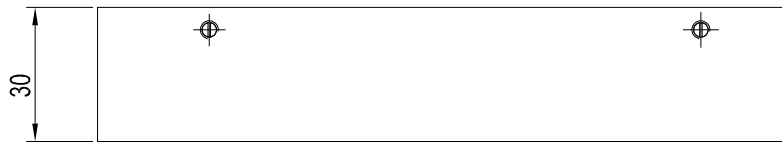
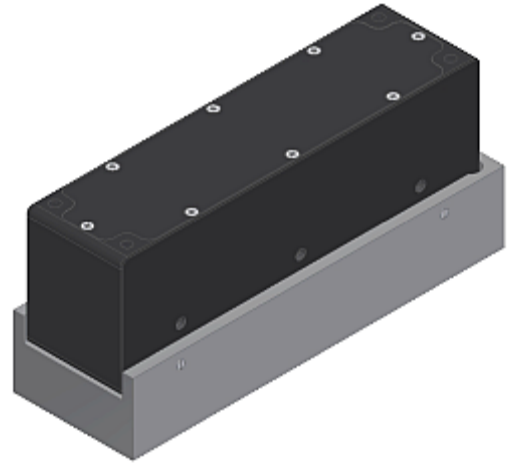
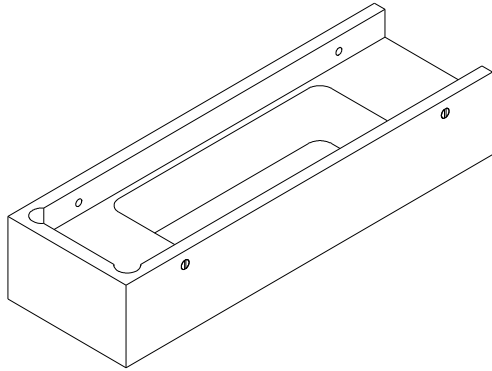

All dimensions in mm