

Pressure transmitter COMPACT IO-Link

for diaphragm seal operation

Type series CA1510

In Proud Partnership with Labom

PAQUIN
SENSORS

For technical support, sales, & distribution
within the USA & Canada

www.paquin.com | (800) 831-8217 | paquinsensors@paquin.com



 IO-Link



Application area

- Pharmaceutical industry
- Food industry
- Biotechnology
- General process technology

Features

- Digital pressure transmitter with IO-Link V1.1 output signal
- Data transmission rate COM 3 (230.4 kBaud)
- Hygienic design as per EHEDG recommendation, selected process connections with EHEDG certificate
- Accuracy $\leq 0.3\%$
- Case and wetted parts of stainless steel, degree of protection IP 65
- Nominal range -400...400 mbar up to -1...100 bar
- 2 switching outputs maximum

Additional features

- Labom REconnect quick coupling device for easy and safe separation and connection of diaphragm seal systems; Type series MK1000, see data sheet DB_D6-022
- Approvals/Certificates
 - Material certificate per EN 10204-3.1
 - Calibration certificate per EN 10204-3.1
 - Roughness height rating with inspection certificate acc. to EN 10204-3.1
- As per UKCA regulations
- Hygienic design
- Wetted parts electropolished

Application

The pressure transmitter COMPACT with IO-Link is suited for measuring the relative pressure of gases, vapors and liquids. Due to the case design as per EHEDG recommendation and various process connections, the transmitter is suitable for the hygienic requirements of plant and machinery engineering.

Technical data

Constructional design / case

Design:	Hygienic case with high moisture protection
Material:	Stainless steel mat.-no. 1.4404/1.4301 (316L/304)
Degree of protection per EN 60529:	IP 65 (IP 69K possible, in combination with suitable connection cable)
Electrical connection:	Circular connector M12 (4 pin) Further connections upon request.

Process connection

Design:	See order details
---------	-------------------

Material wetted parts

Diaphragm:	Stainless steel 316L
------------	----------------------

Nominal ranges and accuracy

Nominal range	Accuracy (based on nominal range)	Temperature influence (-20...80 °C)	Long-term drift (based on nominal range)	Overload protection
-400...400 mbar rel.	≤ 0.4 %	≤ 1.6 %	≤ 0.3 % / year	1 bar
-1...1 bar rel.	≤ 0.3 %	≤ 1.5 %	≤ 0.2 % / year	4 bar
-1...2.5 bar rel.		≤ 1.0 %		16 bar
-1...5 bar rel.		≤ 0.9 %		40 bar
-1...12 bar rel.		≤ 0.7 %		100 bar
-1...30 bar rel.		≤ 0.7 %		100 bar
-1...100 bar rel.		≤ 0.7 %		200 bar

Lower measuring limit 30 mbar abs. Vacuum-proof design is available upon request.

Calibration position: vertical

Temperature influence process connection

Temperature influence medium:	DN 25 / 1"	4.8 mbar/10K
	DN 32 / 1 1/2"	2.3 mbar/10K
	DN 40	1.6 mbar/10K
	DN 50 / 2"	0.6 mbar/10K
	HYGIENIC G1A	1 mbar/10K

The specified zero point error for the process connection is a reference value for a standard design. We can provide a detailed system calculation upon request. Systems with reduced diaphragm seal errors are also available.

Hygienic design

The surface roughness of the wetted parts made of stainless steel are executed according to EHEDG Doc.8 and ASME BPE SF3.

In case of choosing the additional feature HY, we guarantee the following surface roughness values:

Diaphragm foil:	Ra ≤ 0.38 µm
Laser welds:	Ra ≤ 0.76 µm
Turned parts:	Ra ≤ 0.76 µm

Further versions of hygienic design upon request.

Measuring system

Sensor:	Piezoresistive measuring element
System filling:	Synthetic oil FD1, free of silicone, FDA compliant

Output

Signal:	<ul style="list-style-type: none"> ■ IO-Link version 1.1 (downward compatible to version 1.0)
	Conform to IO-Link port class A Data transfer rate COM 3 (230.4 kBaud) Min. cycle time 2 ms 1 switching output cable length (unshielded) ≤ 20 m
	<ul style="list-style-type: none"> ■ optional: 2 switching outputs

Features switching output

Switching functions configurable:	<ul style="list-style-type: none"> ■ Hysteresis function or frame function ■ Normally closed or normally opened ■ Output PNP/High-side or NPN/Low-side
-----------------------------------	---

Switching current:	≤ 100 mA per output
--------------------	---------------------

Voltage drop at switching transistor:	≤ 2 V
---------------------------------------	-------

Short-circuit proof:	yes (clocked)
Reverse polarity protected:	yes
Current limit:	yes
Hysteresis	
for hysteresis function:	configurable
for frame function:	Fixed settings (symmetrical; $\pm 0,25$ % of the measuring range)
Switch-on, switch-off delay:	0.00 to 100,00 s

Supply voltage

Functional area IO-Link:	18...32 V DC *
Functional area 2 output signals:	9.6...32 V DC *
Nominal voltage:	24 V DC

* The auxiliary energy of the pressure sensor must meet SELV requirements; optionally, an energy-limited current circuit according to section 9.3 of EN 610610-1 and UL 61010-1 can be used.

Current consumption:

In idle mode:	≤ 10 mA
IO-Link:	≤ 12 mA
2 switching outputs:	≤ 250 mA

Temperature ranges

Temperature ranges for the design of the diaphragm seal system (in combination with the pressure transmission fluid FD1):

Ambient:	-10...50 °C
Media:	-10...140 °C

Adjusted design temperature ranges within the following maximum values are possible on request:

Ambient:	-40...85 °C
Media:	-40...230 °C

Temperature range for storage:

Storage:	-40...85 °C
----------	-------------

Tests and certificates

EMC:	EN 61326-2-3
------	--------------

Parameterisation

Parameterisation

Parameter	Value range	Default setting
IO-Link general		
Languages IODD	English, German	German
Measurement / Output		
Process data format	Floating point, Integer number	Floating point
Unit pressure	mbar, bar, ftH ₂ O, mmH ₂ O, mmHg, psi, inH ₂ O, inHg, kPa, MPa, kg/cm ² , Torr,, mH ₂ O,	bar
Damping	0,00 bis 100,00 s	0.0
Switching outputs		
Switching function	Off, hysteresis function, normally open, hysteresis function, normally closed, frame function, normally open, frame function, normally closed	Off
Switching point / Upper frame limit	-99999.0 up to 99999.0000	0.0
Reset point / Lower frame limit	-99999.0 up to 99999.0000	0.0
Delay switch point	0.00 up to 100.00 s	0.0
Delay reset point	0.00 up to 100.00 s	0.0
Output function	PNP/Highside, NPN/Lowside	PNP/Highside

Diagnostic functions

Process values	Description	Value range
Status pressure value	Check of the status of the process values	Process data invalid (upper pressure limit exceeded or lower pressure limit undershot), Parameter memory defective, Device failure (defect in the adjustment data)
Min/Max values	Description	Value range
Min/Max values pressure	Check of minimum and maximum process pressure	/
Device status	Description	Value range
Operation hours counter	Capture of operating hours	/
Error counter	Capture of occurred errors	/
Device status	Check of device status	No error, outside the specification (low voltage)
Detailed device status	According to the IO-Link specification	/
Events	Description	Value range
Events	Events that are triggered as soon as an activated error message occurs. Possible error messages: Process data invalid, lower pressure limit undershot or upper pressure limit exceeded, parameter memory defective, defect in the adjustment data or hardware defective, low voltage, temperature error, overload	/

Adjustment

Type	Description
Zero point correction	adjusts reading to zero at ambient pressure
Lower adjustment of characteristic curve	adjusts correction values for lower adjustment point (effects zero point)
Upper adjustment of characteristic curve	adjusts correction values for lower adjustment point (effects span)

Connection diagram

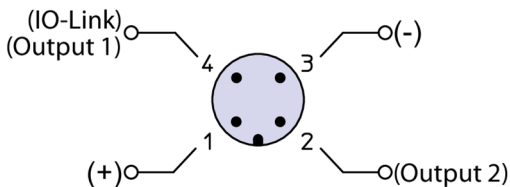

Dimensions

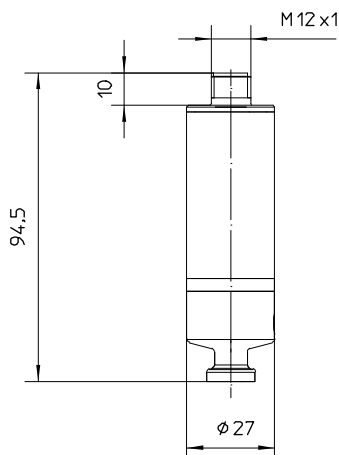

All dimensions are in mm.

Process connection

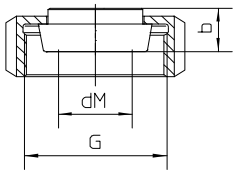

sanitary connection
with coupling nut
per DIN 11851

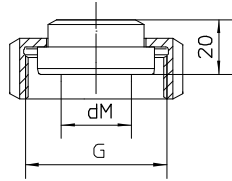

aseptic screw joint
collar connection
with union nut per
DIN 11864-1

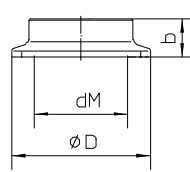

clamp connection
per DIN 32676/ISO 2852

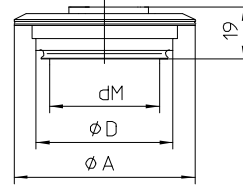

VARIVENT® connection for
VARINLINE® case

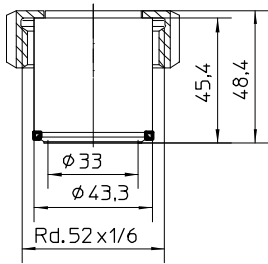

HYGENIC-Tubus *
Ø43,3 with screwing
DN25/PN40

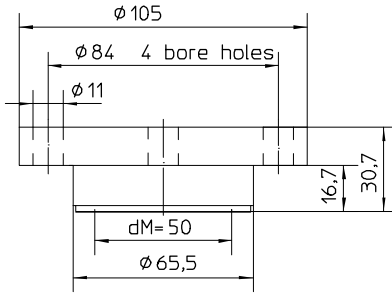

DRD-connection DN50 PN40 *

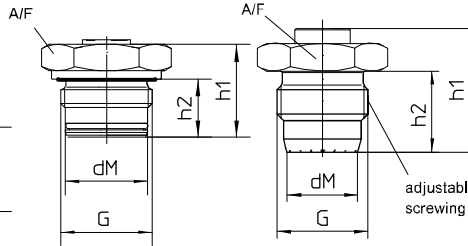

Screw-in thread *
with o-ring-gasket
and additionally gasket
per DIN EN ISO 1179-2
model E (DIN 3852)

HYGENIC-screw-in thread *
no gasket
lightening torque
20 Nm, max. nominal pressure 10 bar
50 Nm, max. nominal pressure 50 bar

* weld-in adapter
see data-sheet D6-037

All dimensions are in mm

Sanitary pipe connection with union nut per DIN 11851

DN	PN	dM	b	G
25	40	27	16	Rd.52x1/6"
32	40	34	16	Rd.58x1/6"
40	40	40	16	Rd.65x1/6"
50	25	51	17	Rd.78x1/6"

Aseptic screw joint collar connection with union nut per DIN 11864-1

DN	PN	dM	G
25	40	24	Rd.52x1/6"
32	40	30	Rd.58x1/6"
40	40	34	Rd.65x1/6"
50	25	48	Rd.78x1/6"

Clamp connection per DIN 32676 model A (metric) for pipes per EN 10357 (DIN 11850)

DN	PN	dM	b	D
25	25	22.6	14	50.5
32	25	27	12	50.5
40	25	34	12	50.5
50	16	46	14	64

Clamp connection per DIN 32676 model B (OD, ISO) for pipes per DIN EN ISO 1127

DN	PN	dM	b	D
26.9	25	22.6	14	50.5
33.7	25	27	12	50.5
42.4	25	34	12	64
48.3	16	40	14	64

Clamp connection per DIN 32676 model C (Tri-Clamp) for pipes per ASME BPE

DN	PN	dM	b	D
3/4"	25	15.5	15	25
1"	25	22.6	14	50.5
1 1/2"	25	34	12	50.5
2"	16	46	14	64

Clamp connection per ISO 2852 for pipes per ISO 2037

DN	PN	dM	b	D
25	16	22.6	14	50.5
38	16	34	12	50.5
51	16	46	14	64

VARIVENT® connection for VARINLINE® access unit

Connection	PN	dM	A	D
Form F	25	40	66	50
Form N	25	58	84	68

HYGENIC screw-in thread, gasket without elastomer

G	PN (bar)	dM	h1	h2	SW
G1 A	50	24	45	28.5	36

Screw-in thread with O ring gasket

G	PN (bar)	dM	h1	h2	SW
G1/2 A	200	15.5	33	20.5	27
G1 A	50	24	33	20.5	41

Order details

Pressure transmitter COMPACT IO-Link for diaphragm seal operation				
CA1510	Pressure transmitter COMPACT IO-Link for diaphragm seal operation			
A1011	Nominal range	-400...400 mbar ¹		
A1053		-1...1,0 bar ¹		
A1055		-1...2.5 bar		
A1621		-1...5 bar		
A1106		-1...12 bar		
A1107		-1...30 bar		
A1063		-1...100 bar		
F1		Parameterisation	standard, according to data sheet (see parameterisation table)	
F9	per customer's specification as in writing			
Q3	Accuracy	≤ 0.3 % of set nominal range		
Q7		≤ 0.4 % of set nominal range ²		
H51	Output signal	IO-Link V1.1		
T120	Electrical connection	circular connector M12 (4 pin)		
T999		as in writing		
K102	Process connection material: ASTM 316L	sanitary pipe connection with union nut per DIN 11851 ^{3,4}	DN 25	
K103			DN 32	
K104			DN 40	
K105			DN 50	
K162			aseptic screw joint collar connection with union nut per DIN 11864-1 ³	DN 25
K163		DN 32		
K165		DN 40		
K166		DN 50		
K124		clamp connection per ISO 2852 for pipes per ISO 2037 ^{3,4}	DN 25 (1")	
K126			DN 38 (1 1/2")	
K127			DN 51 (2")	
K144		clamp connection per DIN 32676, model A (metric) for pipes per EN 10357 (DIN 11850) ^{3,4}	DN 25	
K146			DN 32	
K147			DN 40	
K148			DN 50	
K213		clamp connection per DIN 32676, model B (OD, ISO) per DIN EN ISO 1127 ^{3,4}	DN 26.9	
K214			DN 33.7	
K215			DN 42.4	
K216			DN 48.3	
K134		clamp connection per DIN 32676, model C (Tri-Clamp) for pipes per ASME BPE ^{3,4}	DN 3/4"	
K136			DN 1"	
K137			DN 1 1/2"	
K138			DN 2"	
K152		VARIVENT® connection ^{3,4}	Form F (D=50) for VARINLINE® access unit	
K153			Form N (D=68) for VARINLINE® access unit	
K172		HYGIENIC Tubus	Ø 43.3 mm with screwing DN 25/PN 40	
K185		DRD connection	nominal width DN 50 / nominal pressure PN 40	
K194		screw-in thread	G1/2 A with O-ring seal	
K195			G 1 A with O-ring seal	
K80			G 1 A with hygienic process connection (elastomer-free)	
P1	Design temperature medium	-10...140 °C		
P9		variant as in writing		

Additional features (to be indicated if required)	
HY	Hygienic version as per EHEDG Doc.8 and ASME BPE SF3 (surface roughness wetted parts)
W1020	Material certificate per DIN EN 10204-3.1, wetted parts
W1201	Calibration certificate per DIN EN 10204-3.1, 5 measuring points
W1223	Roughness height rating with inspection certificate acc. to EN 10204-3.1
W2660	As per UKCA regulations
W4035	Electropolishing of wetted parts

Order code (example): CA1510 – A1011 – F1 - H51 - T120 - K126

¹ for a function calculation and optimum system design in combination with pressure transmitter \leq DN 25 (1") it is necessary to specify the operation temperature.

² for nominal range -400...400 mbar rel., only

³ EHEDG certified only in connection with hygienic design (order code option HY)

⁴ EHEDG certificate valid only if gaskets are used that are listed in the "EHEDG position paper"