

In Proud Partnership with Sensor Instruments

**PAQUIN**  
SENSORS

For technical support, sales, & distribution  
within the USA & Canada

www.paquin.com | (800) 831-8217 | paquinsensors@paquin.com

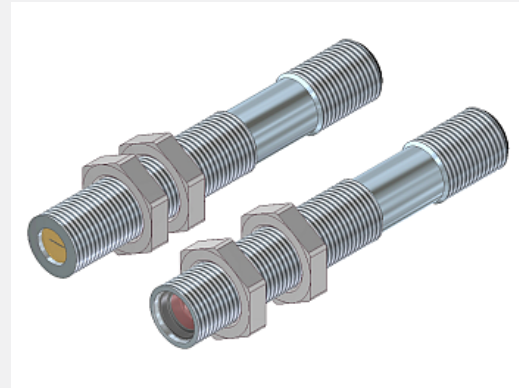

# D-LAS Series

## ▶ D-LAS2-...-HS (High Speed)

- Visible laser beam (<0.4 mW, 670 nm), **laser class 1**
- Extremely high switching frequency (typ. 300 kHz)
- Various apertures available
- Receiver aperture alternatively with collecting lens or with particular lens for more accurate switching point
- Interference filter
- High reproducibility (in µm-range)
- Analog output (0V...+10V)
- Switching output (npn + pnp)
- Optics cover made of glass
- Sturdy housing made of brass, nickel-plated
- Compact design (M12)



## Design

### Product name:

**Transmitter:**  
D-LAS2-(aperture)\*-T

**Receiver (standard version):**  
= with collecting lens, aligned to transmitter aperture

D-LAS2-Q-(aperture)\*-R-HS  
D-LAS2-Qinv-(aperture)\*-R-HS  
D-LAS2-TC-Q-(aperture)\*-R-HS  
D-LAS2-TC-Qinv-(aperture)\*-R-HS

**Receiver (special version A):**  
= with particular receiver aperture (max. AxB = 3x0.75), aligned to reference transmitter aperture

D-LAS2-Q-A-(receiver aperture)\*-(reference transm. aperture)-R-HS  
D-LAS2-Qinv-A-(receiver aperture)\*-(reference transm. aperture)-R-HS  
D-LAS2-TC-Q-A-(receiver aperture)\*-(reference transm. aperture)-R-HS  
D-LAS2-TC-Qinv-A-(receiver aperture)\*-(reference transm. aperture)-R-HS

### \*Available apertures:

Round (Ø in mm):	Rectangular (AxB in mm):
d0.15	0.5x0.3
d0.2	1x0.3
d0.3	1x0.5
d0.5	1.5x0.3
d0.7	2x0.75
d1.0	2x1
d2.0	3x0.3
d3.0	3x0.75
	4x0.5 (available only with standard type)

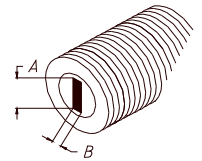

- Q = Switching output:  
npn dark-switching (npn n.o.)/  
pnp bright-switching (pnp n.c.)
- Qinv = Switching output:  
pnp dark-switching (pnp n.o.)/  
npn bright-switching (npn n.c.)
- TC = Threshold correction
- HS = High speed (extremely high switching frequency)

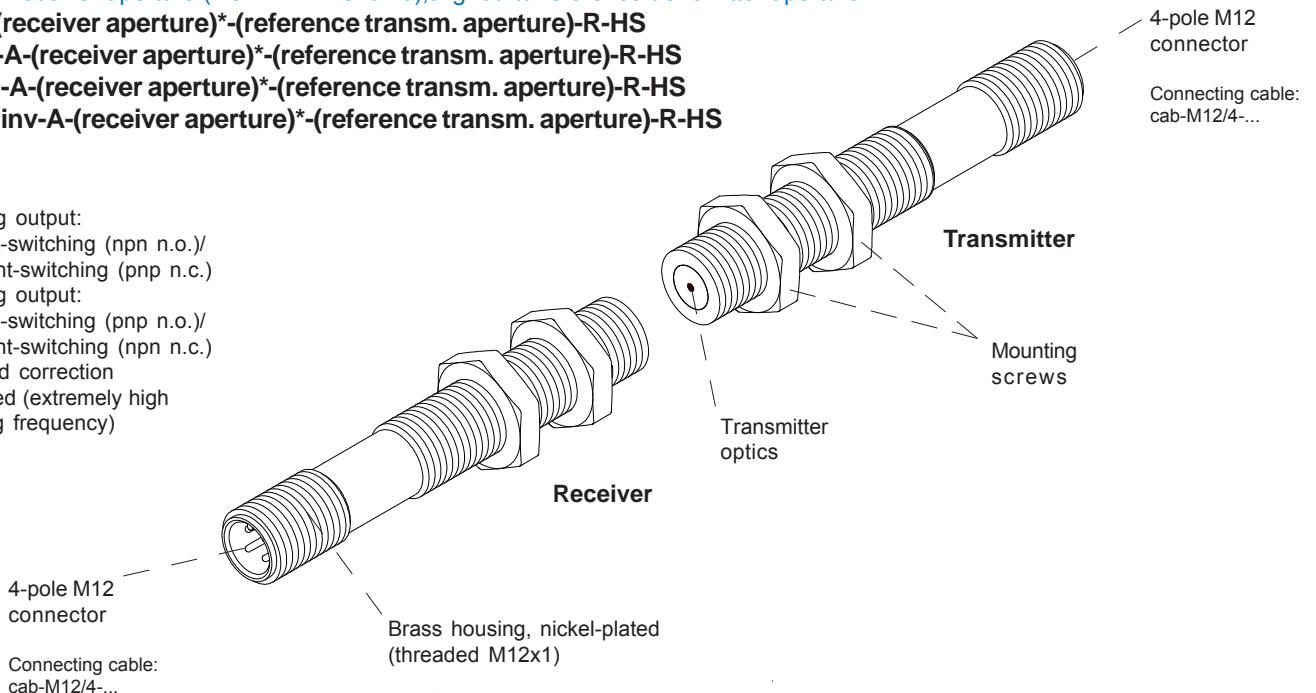



**Technical Data**

Type	D-LAS2-HS (High Speed)
Laser	Solid state laser, 670 nm, AC operation, <0.4 mW opt. power, laser class 1 acc. to DIN EN 60825-1. The use of these laser transmitters therefore requires no additional protective measures.
Max. range	30 m (depends on the aperture used)
Min. detectable object	Analog typ. 2% of aperture size, digital typ. 1% of aperture size
Reproducibility	Analog typ. 2% of aperture size, digital typ. 1% of aperture size, with threshold correction "TC": typ. 0.1% of aperture size
Optical filter	Interference filter
Threshold correction	with type "TC"
Voltage supply	+24VDC (± 10%), protected against polarity reversal, overload protected
Alternating current/ direct current supply	DC operation
Ambient light	up to 5000 Lux (depends on the aperture used)
Current consumption	Transmitter: typ. 50 mA      Receiver: typ. 30 mA
Max. size of aperture	Round aperture: max. Ø 3.0 mm Rectangular aperture: max. 4 mm x 0.5 mm  Receiver special version A: Receiver aperture max. 3 mm x 0.75 mm (is aligned to reference transmitter aperture)
Current control input I-CONTROL	0V...+5V: Laser power decreases linearly with increasing voltage +5V...+24V: Laser OFF (max. modulation/frequency: 2 kHz)
Monitoring output	Analog output 0V...+10V (typ. 100 kHz band width, -3dB)
Digital output	Q = pnp bright-switching (pnp n.c.)    or Qinv = pnp dark-switching (pnp n.o.)
Type of protection	IP67
Operating temperature range	-20°C up to +50°C
Storage temperature range	-20°C up to +85°C
Housing material	Brass, nickel-plated
Housing dimensions	Transmitter: M12x1, length approx. 76 mm Receiver standard version with collecting lense: M12x1, length approx. 80 mm Receiver special version A with particular aperture: M12x1, length approx. 76 mm
Connector type	M12, 4-pole (V2A-plug)
Connecting cables available	cab-M12/4-g-... (length 2m or 5m) cab-M12/4-w-... (length 2m or 5m, angle type) cab-M12/4-w-npn-... (length 2m or 5m, angle type, with LED) cab-M12/4-w-pnp-... (length 2m or 5m, angle type, with LED)
Current output	Max. output current with pnp-output: 2mA Max. output current with npn-output: 10mA Min. resistance to 0V (GND): 10kOhm (with pnp-output) Min. resistance to + : 2kOhm (with npn-output)
EMC test acc. to	DIN EN 60947-5-2 <b>CE</b>
Switching frequency	typ. 300 kHz

## Aperture Ranges

Max. ranges of D-LAS2 transmitter and receiver depending in the selected aperture:

**Round aperture (Ø mm):**

d0.15	Range of D-LAS2:
d0.2	(will be supplemented still)
<b>d0.3</b>	<b>max. 2 m</b>
<b>d0.5</b>	<b>max. 4 m</b>
d0.7	(will be supplemented still)
<b>d1.0</b>	<b>max. 8 m</b>
<b>d2.0</b>	<b>max. 18 m</b>
<b>d3.0</b>	<b>max. 30 m</b>

**Rectangular aperture (AxB mm):**

0.5 x 0.3	Range of D-LAS2:
1 x 0.3	(will be supplemented still)
1 x 0.5	(will be supplemented still)
1.5 x 0.3	(will be supplemented still)
2 x 0.75	(will be supplemented still)
2 x 1	(will be supplemented still)
<b>3 x 0.3</b>	<b>max. 0.5 m</b>
3 x 0.75	(will be supplemented still)
4 x 0.5	(will be supplemented still)

## Dimensions

D-LAS2-...-T  
Transmitter

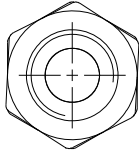

D-LAS2-...-R-HS  
Receiver  
(with collecting  
lense)

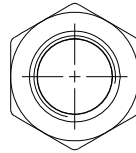

D-LAS2-...-A-...-R-HS  
Receiver  
(with particular  
receiver aperture)

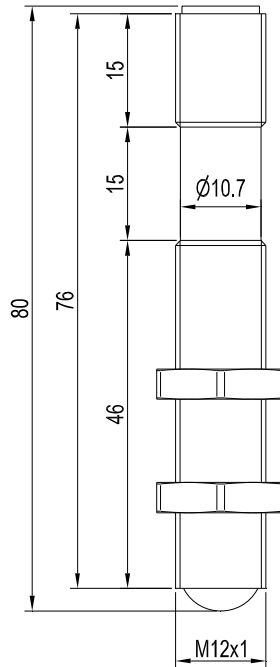
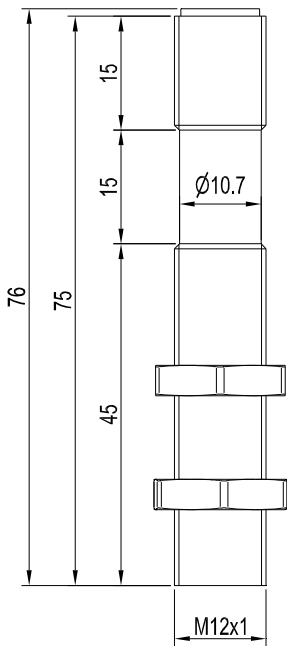
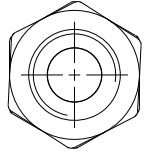

(All dimensions in mm)

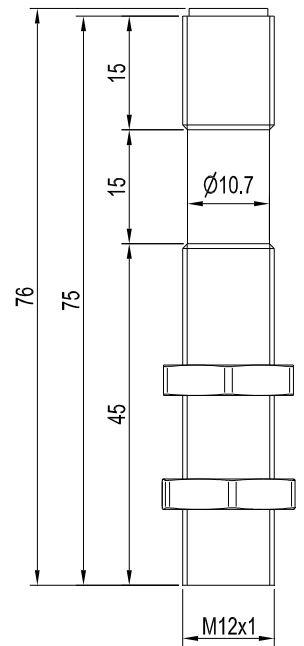

## Laser Information

The laser transmitters of D-LAS series comply with laser class 1 according to EN 60825-1. Under reasonably foreseeable conditions a class 1 laser is safe. The reasonably foreseeable conditions are kept during specified normal operation. The use of these laser transmitters therefore requires no additional protective measures.

The laser transmitters of D-LAS series are supplied with an information label „CLASS 1 Laser Product“.

**CLASS 1 Laser Product**  
IEC 60825-1: 2008-05  
THIS LASER PRODUCT COMPLIES  
WITH 21 CFR 1040 AS APPLICABLE



**Connector Assignment**

**Receiver** (4-pole M12 connector, shielded)

**D-LAS2-Q-(aperture)-R-HS or  
D-LAS2-TC-Q-(aperture)-R-HS:**

Pin No.:	Color:	assignment:
1	brn	+24VDC (± 10%)
2	wht	ANALOG (0V...+10V)
3	blu	GND (0V)
4	blk	OUTPUT Q (pnp bright-switching)

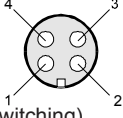

**Transmitter** (4-pole M12 connector, shielded)

**D-LAS2-(aperture)-T**

Pin No.:	Color:	Assignment:
1	brn	+24VDC (± 10%)
2	wht	I-CONTROL (0...+24V)
3	blu	GND (0V)
4	blk	Shield - Housing

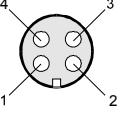

**TD-LAS2-Qinv-(aperture)-R-HS or  
D-LAS2-TC-Qinv-(aperture)-R-HS:**

Pin No.:	Color:	Assignment:
1	brn	+24VDC (± 10%)
2	wht	ANALOG (0V...+10V)
3	blu	GND (0V)
4	blk	OUTPUT Qinv (pnp dark-switching)

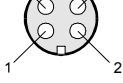

**Connecting Cables**

**Available connecting cables:**

<b>cab-M12/4-g-2m</b>	Length: 2m	Outer jacket: PUR	
<b>cab-M12/4-g-5m</b>	Length: 5m	Outer jacket: PUR	
<b>cab-M12/4-w-2m</b>	Length: 2m	Outer jacket: PUR	angle type
<b>cab-M12/4-w-5m</b>	Length: 5m	Outer jacket: PUR	angle type
<b>cab-M12/4-w-npn-2m</b>	Length: 2m	Outer jacket: PUR	angle type, with LED
<b>cab-M12/4-w-npn-5m</b>	Length: 5m	Outer jacket: PUR	angle type, with LED
<b>cab-M12/4-w-pnp-2m</b>	Length: 2m	Outer jacket: PUR	angle type, with LED
<b>cab-M12/4-w-pnp-5m</b>	Length: 5m	Outer jacket: PUR	angle type, with LED

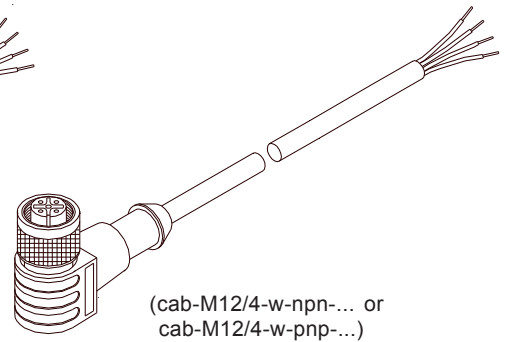
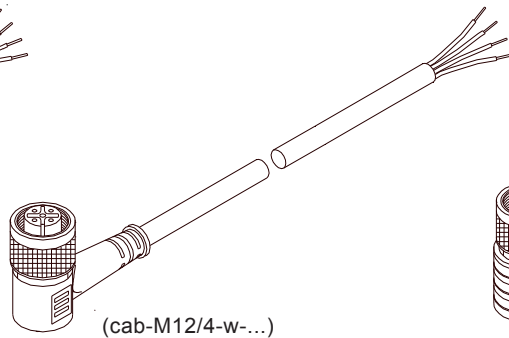
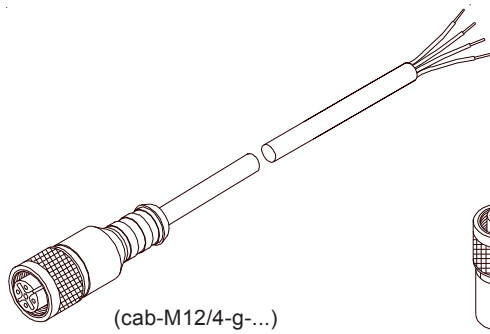
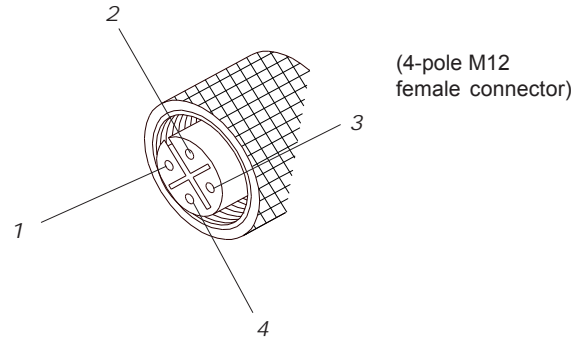

**Mounting**

**Mounting accessories** (please order separately):

**Mounting flange FL-12  
Mounting flange WFL-12**

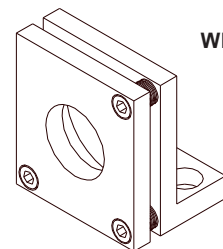
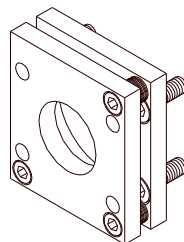

**Characteristics**

**Adjustment of laser power**

At the D-LAS2 transmitter the laser power can be adjusted with the current control input.

The voltage at the I-CONTROL current control input can be varied between 0V and +24V. The maximum laser power is reached at 0V; the laser power then decreases linearly with increasing voltage, and at +5V it reaches the 0 mW value (LASER OFF).

The current control input therefore can also be used as a test input for switching the laser light barrier on or off (0V = ON, +5V or +24V = OFF).

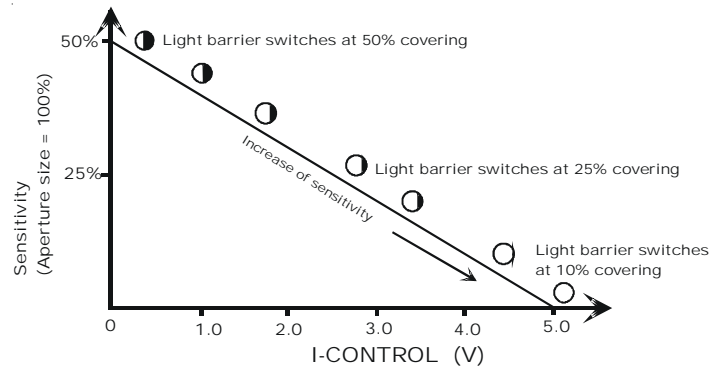

**Adjustment of sensitivity**

If a receiver with a fixed comparator threshold is used, the I-CONTROL input is used for setting the sensitivity.

Drawing at the right: Sensitivity increase in case of a receiver with fixed threshold (threshold set to a fixed value of 5V, which in case of an analog signal of 10V (with I-CONTROL = 0V) requires a 50% covering of the laser beam for a change of the switching state.

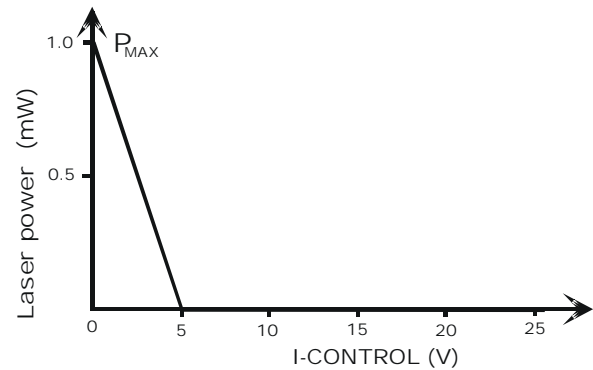

**Monitoring Output**

**Dirt accumulation and cleaning**

The monitor output of the receiver provides information on the dirt accumulation status of the laser light barrier. The lower the value of the analog signal (without measuring object in the beam path), the higher the dirt accumulation.

If possible, a dry cleaning method should be used for cleaning the glass covers and/or the glass lenses, preferably with a spectacles cleaning cloth, or a similar cloth.

The formation of drops on the glass cover or the glass lens might impair the measuring result (refraction of light at the convex drop surface). Drops should be removed with a dry cloth, preferably with a spectacles cleaning cloth, or a similar cloth.

**Graphs**

