

# COAST Series

## ▶ COAST-56-45°-VIS-IR4

- Recommended measurement distance: 56 mm ± 2 mm
- Big dynamic range due to focused white-light operation
- Two controllers in one sensor (color and gloss+structure)
- Up to 31 surfaces/vectors (48 in group mode) can be stored
- RS232 interface (USB or Ethernet converter is available)
- 2 ring light illuminations with each 9 super-bright white-light LEDs, focused (AC-/DC-operation, can be switched)
- 1 ring light illumination with 9 IR LEDs (NIR range), focused
- Evaluation of the forward and backward scattering (alternating)
- Color detection, gloss detection, contrast detection, gray scale detection as well as structure evaluation
- Insensitive to outside light (in AC-operation)
- Several TEACH functions (via PC, PLC, or push button)
- Evaluation according to the „Minimal Distance Principle“
- Switching state display by means of 5 yellow LEDs
- Parameterizable via Windows® software, scope function
- Temperature compensated
- 3-color filter detector (true color detector: “human color perception”) as well as line detector and NIR detector

In Proud Partnership with Sensor Instruments



For technical sales & distribution within the USA & Canada



### Design

**Product name:**

**COAST-56-45°-VIS-IR4**  
(incl. Windows® software COAST-Scope and COAST-STRUCT-Scope)

45°: Optical axes of the two ring lights are inclined each at an angle of 45° from the vertical.

**Accessories:** (p. 12)

**COAST-52-45°-OFL**  
Top part for optics (spacer)

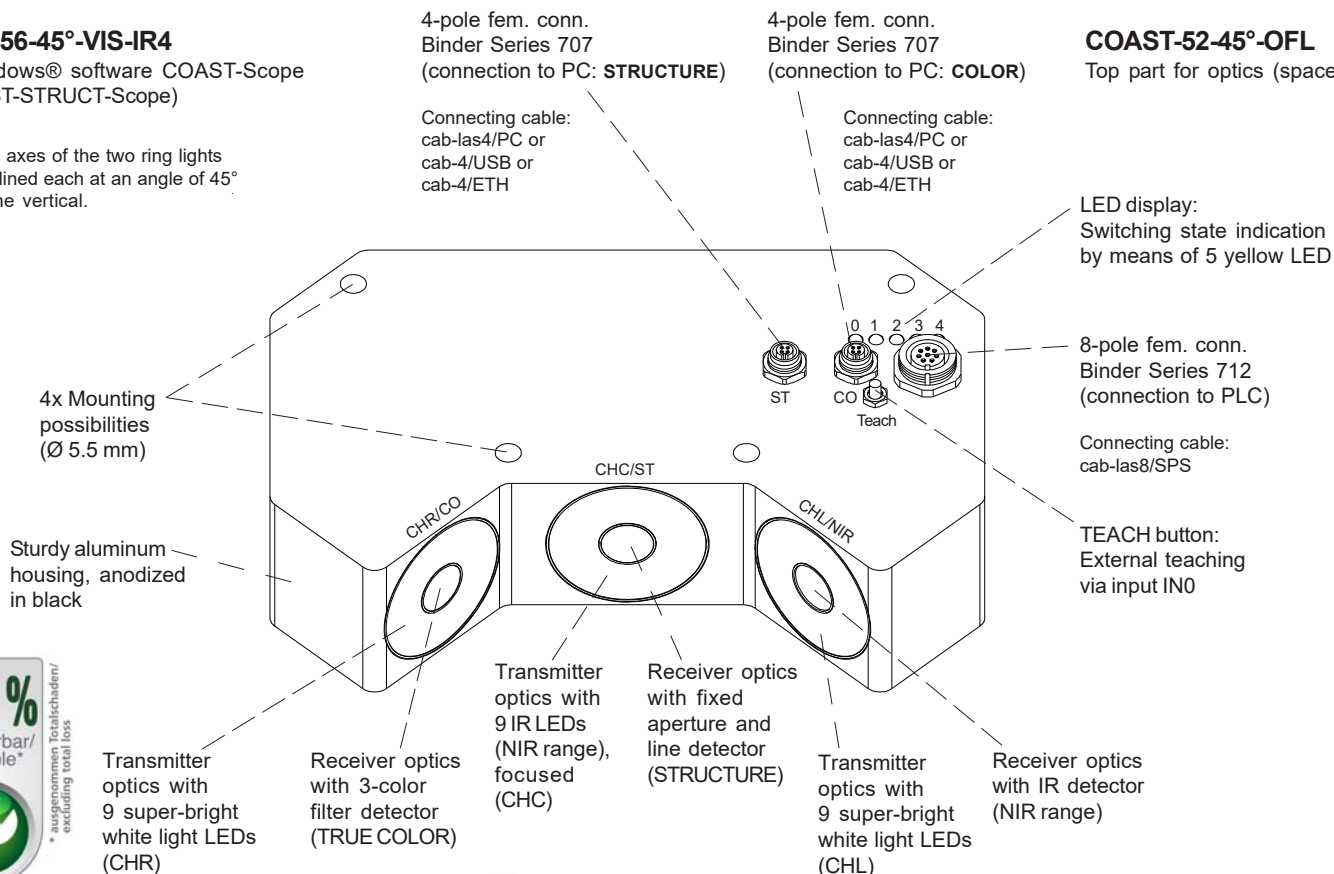



**Technical Data**

| Model  | COAST-56-45°-VIS-IR4  |
|--|---|
| Voltage supply   | +24VDC (± 10%), reverse polarity protected, overcurrent protected   |
| Current consumption  | < 500 mA  |
| Max. switching current   | 100 mA, short circuit proof   |
| Switching state indication   | 5 yellow LED visualize the physical state of the outputs OUT0 ... OUT4  |
| Input digital (1x)   | Teach-in of new surfaces (vectors), can be activated via PC software  |
| Outputs digital (5x)   | OUT0...OUT4 (Pin 4..8): digital (0V/+24V), pn-/pnp-able (bright-/dark-switching, can be switched)   |
| Interface (2x)   | Color/IR sensor (CO): RS232, structure sensor: (ST) RS232   |
| Pulse lengthening  | 0 ... 100 ms ( adjustable via PC software)  |
| Averaging  | max. 32768 values (adjustable via PC software)  |
| Scan frequency<br>(alternating light operation/<br>direct light operation) | LED operation, can be switched via PC software:<br>Color sensor in AC operation: max. 15 kHz (depends on parameterization)<br>Color sensor in DC operation: max. 35 kHz (depends on parameterization)<br>Structure sensor: max. 100 Hz (depends on parameterization)  |
| Angle of incidence   | Optical axes of the two ring lights are inclined each at an angle of 45° from the normal (vertical)   |
| Measuring distance   | typ. 56 mm ± 2 mm   |
| Transmitter (light source)   | 2 ring light illuminations with each 9 super-bright white-light LED, focused<br>1 ring light illumination with 9 IR LEDs (NIR range), focused   |
| Transmitter control  | Can be switched via PC software: AC operation (LED MODE-AC), DC operation (LED MODE-DC)   |
| Receiver   | Color sensor: 3-color filter detector (TRUE COLOR detector), color filter curves acc. to CIE 1931<br>IR sensor: NIR detector<br>Structure sensor: line detector   |
| Receiver gain setting<br>respectively exposure time                        | Color sensor and IR sensor: 8 steps (AMP1 ... AMP8), adjustable via PC software<br>+ INTEGRAL (software implemented addition of consecutive values)<br>Structure sensor: software implemented adjustment of exposure time (EXPOSURE TIME)   |
| Ambient light  | max. 5000 Lux   |
| Detection range  | typ. 20 mm(elliptical) at a distance of 56 mm   |
| Reproducibility  | Color sensor: in siM range typ. 0,5% of measuring range<br>IR sensor: in NIR range typ. 0,5% of measuring range<br>Structure sensor: typ. ± 0,5% of measuring range (20 mm)   |
| Temperature drift X,Y  | $\Delta X/\Delta T; \Delta Y/\Delta T$ typ. 0.2 digits/°C (< 0.01% / °C)  |
| Resolution   | Color sensor: $\Delta E \geq 0.5$<br>IR sensor: typ. 0.5% of measuring range<br>Structure sensor: typ. ± 0.5% of measuring range (20 mm)  |
| Color space (color sensor)   | siM   |
| Memory capacity  | Non-volatile EEPROM with parameter sets for max. 48 vectors   |
| Housing dimensions   | LxWxH approx. 150 mm x 94.8 mm x 36 mm (without connectors)   |
| Housing material   | Aluminum, anodized in black   |
| Enclosure rating   | IP64  |
| Type of connector  | 1x to PLC: 8-pole flange connector (Binder 712)<br>2x to PC/RS232 interface (1x for color/IR Sensor, 1x for structure sensor): 4-pole flange connector (Binder 707)   |
| Connecting cables  | 1x to PLC: cab-las8/SPS or cab-las8/SPS-w<br>2x to PC/RS232 interface: cab-las4/PC or cab-las4/PC-w (1x for color/IR sensor, 1x for structure sensor)<br>or: 2x to PC/USB interface: cab-4/USB or cab-4/USB-w (1x for color/IR sensor, 1x for structure sensor)<br>or: 2x to PC/Ethernet interface: cab-4/ETH (1x for color/IR sensor, 1x for structure sensor) |
| Temperature ranges   | Operating temperature range: -20°C ... +55°C, storage temperature range: -20°C ... +85°C  |
| EMC test acc. to   | DIN EN 60947-5-2  |





**Connector Assignment**

**Connection to PLC:**

**8-pole fem. connector Binder Series 712**

| Pin: | Color: | Assignment:   |
|------|--------|---------------|
| 1    | white  | GND (0V)      |
| 2    | brown  | +24VDC (±10%) |
| 3    | green  | IN0           |
| 4    | yellow | OUT0 (0V/+Ub) |
| 5    | grey   | OUT1 (0V/+Ub) |
| 6    | pink   | OUT2 (0V/+Ub) |
| 7    | blue   | OUT3 (0V/+Ub) |
| 8    | red    | OUT4 (0V/+Ub) |

Connecting cable:  
 cab-las8/SPS-(length)  
 cab-las8/SPS-w-(length) (angle type, 90°)  
 (standard length 2m)

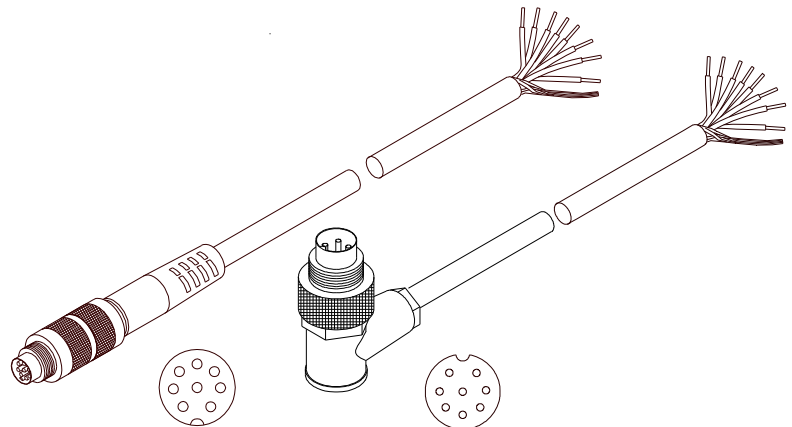

cab-las8/SPS-...  
 (max. length 25m, outer jacket: PUR)

cab-las8/SPS-w-...  
 (max. length 25m, outer jacket: PUR)

**2x connection to PC (1x STRUCTURE side „ST“, 1x COLOR side „CO“):**

**4-pole fem. connector Binder Series 707**

| Pin: | Assignment:       |
|------|-------------------|
| 1    | +24VDC (+Ub, OUT) |
| 2    | GND (0V)          |
| 3    | RxD               |
| 4    | TxD               |

**Connection via RS232 interface at the PC:**

Connecting cable:  
 cab-las4/PC-(length)  
 cab-las4/PC-w-(length) (angle type 90°)  
 (standard length 2m)

**alternative:**

**Connection via USB interface at the PC:**

USB converter (incl. driver software):  
 cab-4/USB-(length)  
 cab-4/USB-w-(length) (angle type 90°)  
 (standard length 2m)

**alternative:**

**Connection to local network via Ethernet bus:**

Ethernet converter (incl. software „SensorFinder“):  
 cab-4/ETH-500  
 (standard length 0.5m)

Optional: External CAT5 cable, e.g.  
 cab-eth/M12D-RJ45-fix-(length)

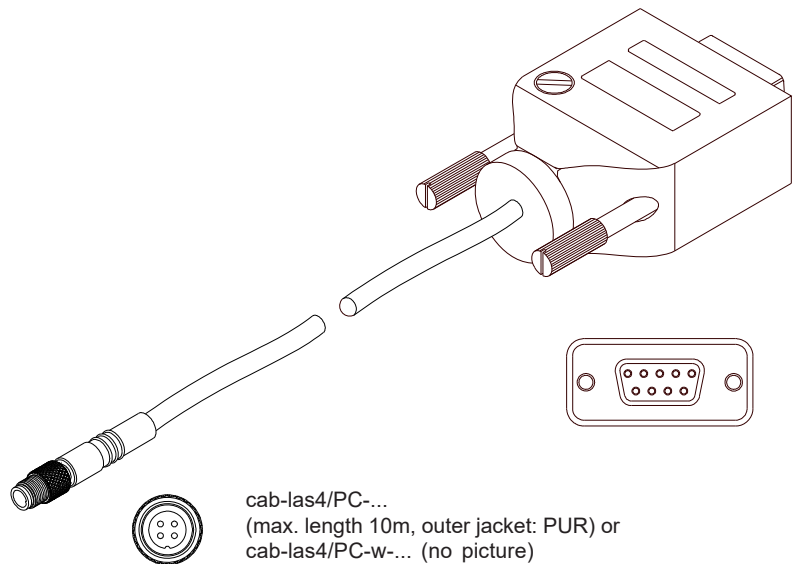

cab-las4/PC-...  
 (max. length 10m, outer jacket: PUR) or  
 cab-las4/PC-w-... (no picture)  
 (max. length 5m, outer jacket: PUR)

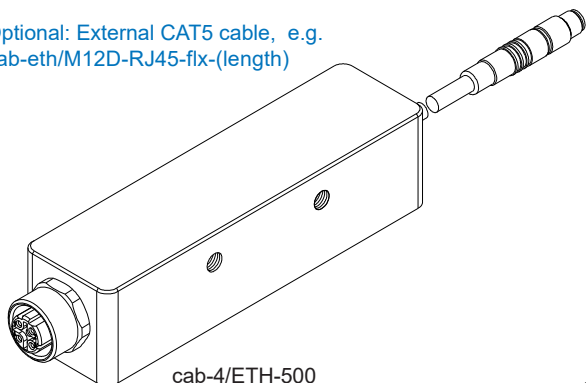

cab-4/ETH-500  
 (length 0.5m, outer jacket: PUR)  
 4-pole M12 fem. conn. (D-coded)  
 for connection of an external  
 CAT5 cable, e.g.  
 cab-eth/M12D-RJ45-fix-(length)

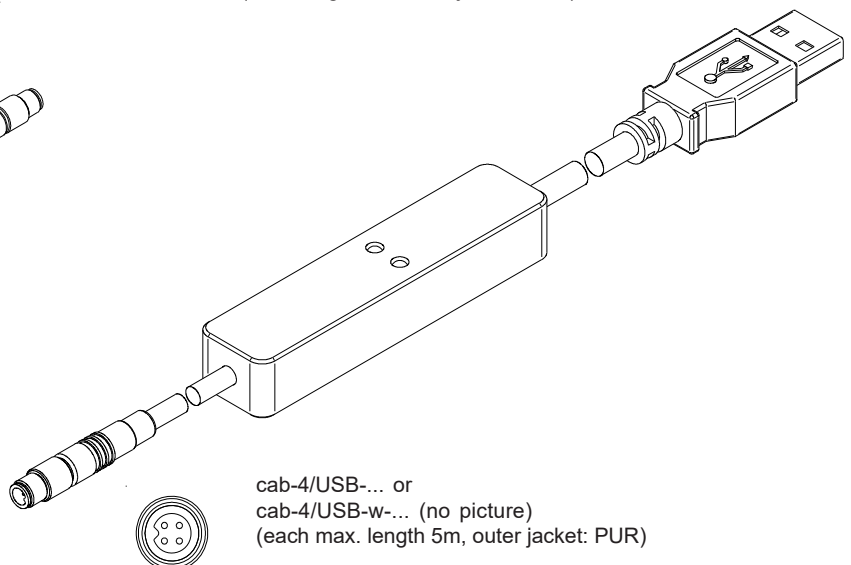

cab-4/USB-... or  
 cab-4/USB-w-... (no picture)  
 (each max. length 5m, outer jacket: PUR)

**Measuring Principle****Measuring principle of the sensors of COAST Series:**

The sensors of the **COAST** series (**CO**lor **And** **ST**tructure) are hybrid sensors consisting of a colour sensor, a structure sensor and an additional channel, which depending on the type, can be fitted with various LEDs (e.g. IR transmitter and a corresponding receiver).

The color sensor detects the color of the object to be inspected by means of two white light illuminations (forward and backward reflection).

The IR sensor detects the reflection of the object to be inspected using IR lighting (in the NIR range).

The structure sensor detects data concerning the surface structure of the object, and through an internal interface sends these data to the color sensor controller.

The color sensor controller then evaluates the color data and the surface data together with the data it receives from the structure sensor. It also controls the digital inputs and outputs and communicates with the **COAST-Scope** PC software.

The available interfaces include a PLC interface, a RS232 interface for the color sensor, and a RS232 interface for the structure sensor. The structure sensor is factory-preconfigured in such a way that it only requires parameterisation in exceptional cases. For this purpose a special **COAST-STRUCT-Scope** software is available.

The COAST sensor provides highly flexible signal acquisition. For example, the sensor can be operated in alternating-light mode (AC mode), which makes the sensor insensitive to extraneous light. It also can be set to constant-light mode (DC mode), which makes the sensor extremely fast and allows a scan-frequency of up to 35 kHz. With the stepless adjustment of the integrated light sources as well as the selectable gain of the receiver signal and an INTEGRAL function the sensor can be set to almost any surface.

The COAST sensor detects the diffuse radiation reflected from the measurement object. Two white-light LED ring lights and a third ring light depending on the sensor type serve as a light source on the COAST sensors. Each has an adjustable transmitter performance. An integrated 3-fold receiver for the red, green, and blue component of the light that is reflected from the object and impinging on the color detector is used as a receiver. The surface structure of the measurement object is mapped on a line sensor by means of an optical aperture system. The receiver of the third channel is dependent on the sensor type.

The sensors of the COAST series can be taught up to 31 surfaces, hereinafter referred to as **teach vectors** or **vectors**, that can be directly provided at the outputs, and up to 48 vectors that can be output by way of grouping. The vector that shows the smallest deviation from the current surface (minimum distance) is provided at the output.

The respective detected vector either is provided as a binary code at the 5 digital outputs or can be sent directly to the outputs, if only up to 5 vectors are to be detected. At the same time the detected vector is visualised by means of 5 LEDs at the housing of the COAST sensor.

With a TEACH button at the sensor housing the sensor can be taught up to 31 vectors (max. 48 vectors in group mode). For this purpose the corresponding evaluation mode must be set with the software. The TEACH button is connected in parallel to the input IN0 (green wire at cable cab-las8/SPS).

Parameters and measurement values can be exchanged between a PC and the COAST sensor through the serial RS232 interface. All the parameters can be saved to the non-volatile EEPROM of the COAST sensor through this serial RS232 interface. When parameterisation is finished, the sensor continues to operate with the current parameters in STAND-ALONE mode without a PC.



Measuring Principle

**Measuring principle of the sensors of COAST Series:**

The ring light is automatically switched over (backward scattering light / forward scattering light).

Backward reflection is used  
(viewed from the color sensor)

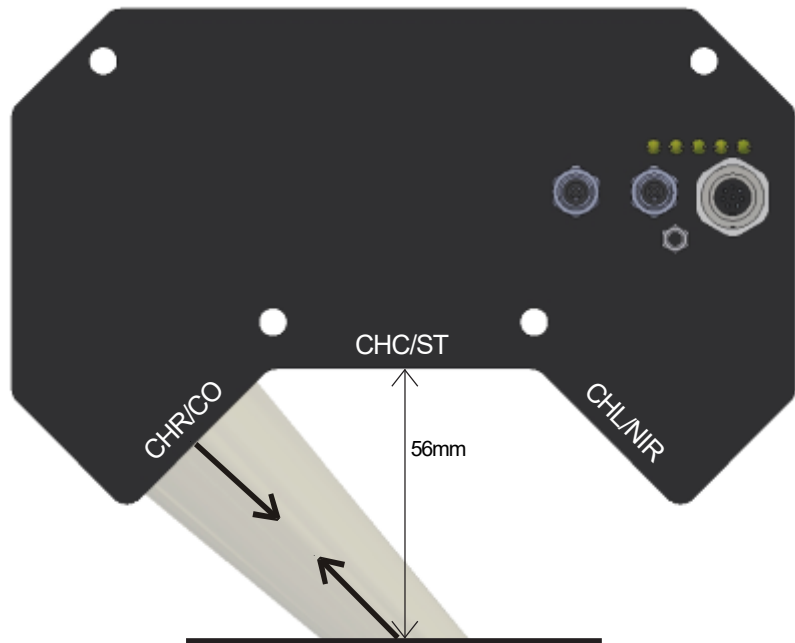

Backward reflection is used  
(viewed from the structure sensor)

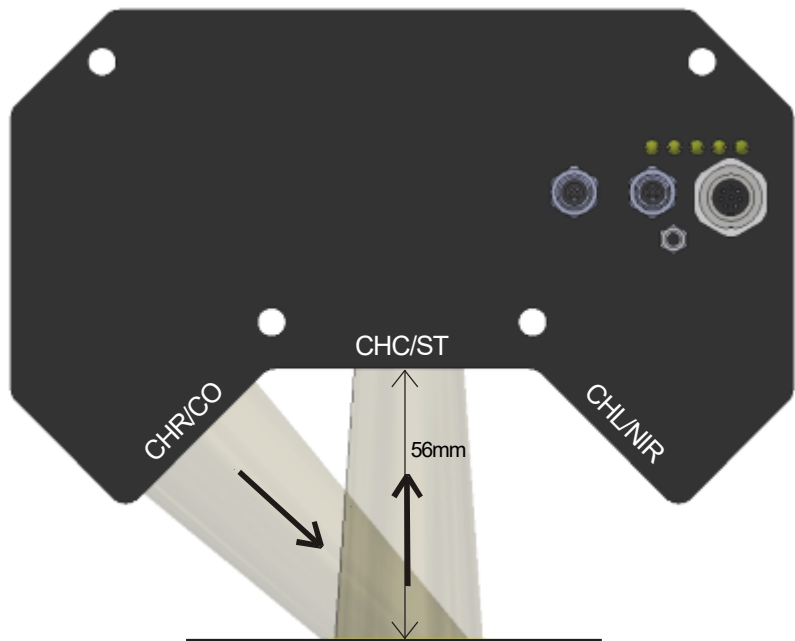



Measuring Principle

Forward reflection is used  
(viewed from the color sensor)

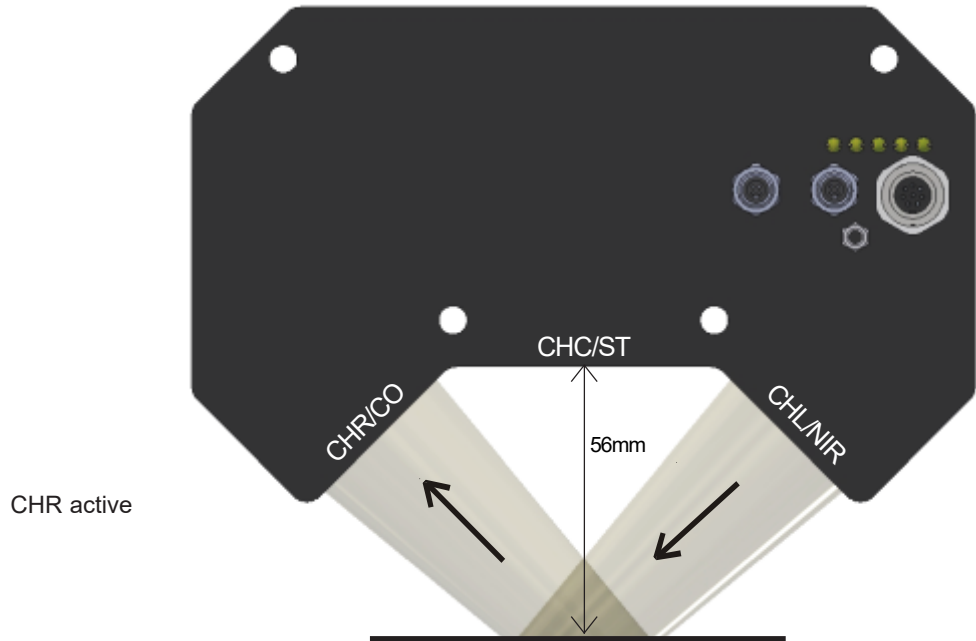

Forward reflection is used  
(viewed from the structure sensor)

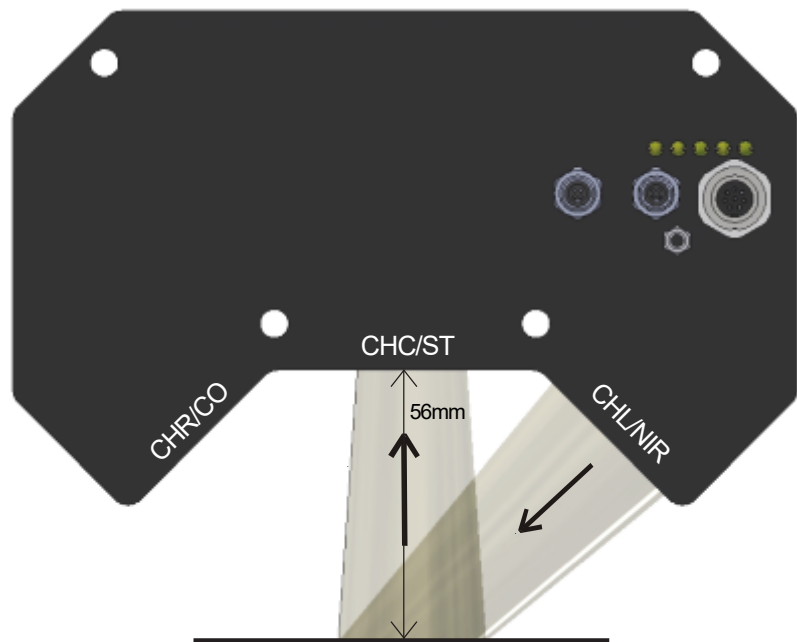



Measuring Principle

IR reflection is used  
(viewed from the structure sensor)

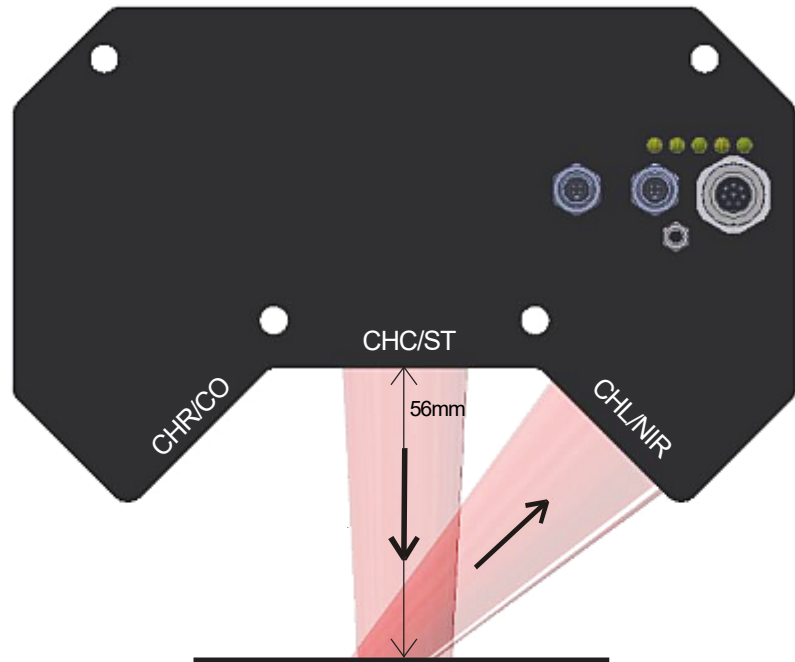





LED Display

**Visualization of the teach vectors via LED display:**

By means of 5 yellow LEDs, the detected vector is visualized on the housing of the COAST sensor. The vector displayed on the LED display is additionally output at the digital outputs OUT0 ... OUT4 of the 8-pin PLC fem. connector.

The output is determined by means of the parameter OUTMODE (in the example on the right, OUTMODE = BINARY HI):

With OUTMODE = BINARY HI or BINARY LO, a maximum of 31 vectors or vector groups can be taught. These are then output in binary form at the outputs.

With OUTMODE = DIRECT HI or DIRECT LO, a maximum of 5 vectors or vector groups can be taught. These are output directly at the outputs.

If COLOR GROUPS = ON, the sensor can be taught up to 48 vectors. However, only 31 groups can be formed with OUTMODE = BINARY, and only 5 groups can be formed with DIRECT.

Detail:

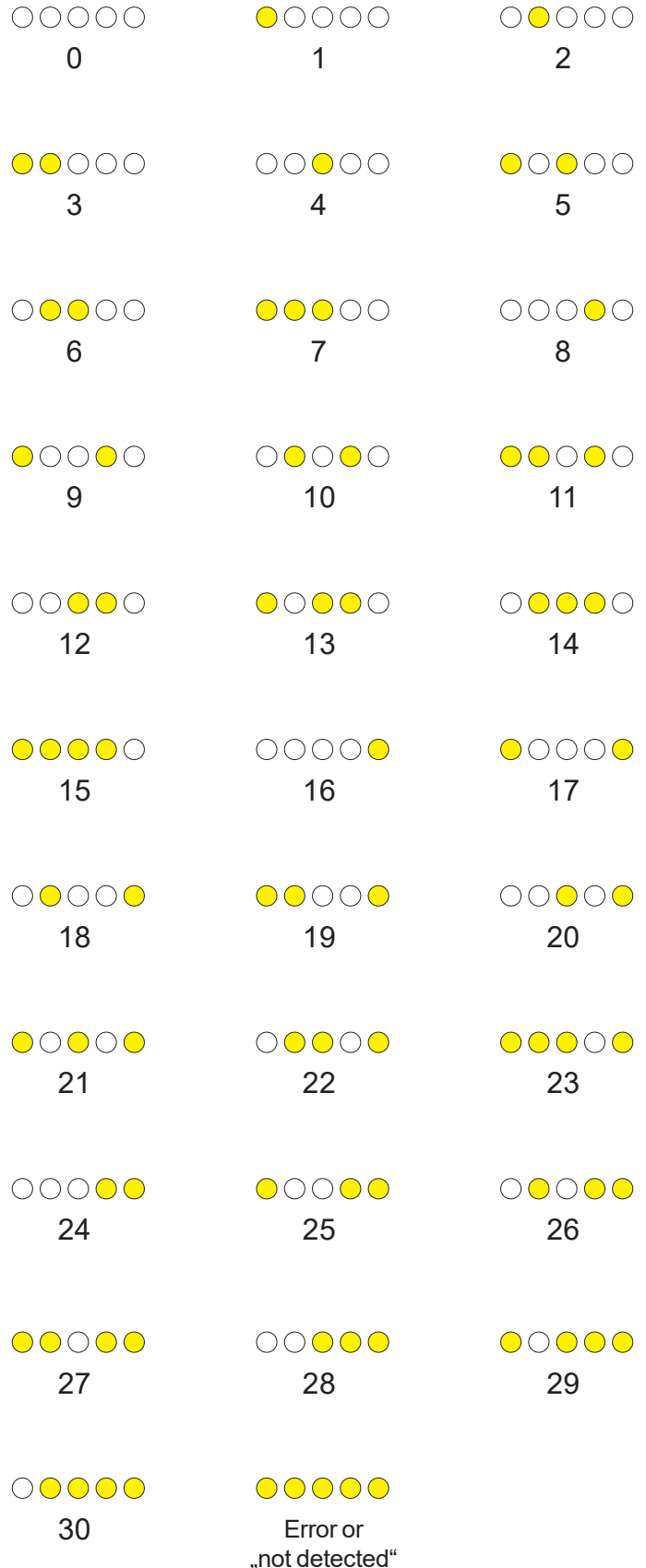
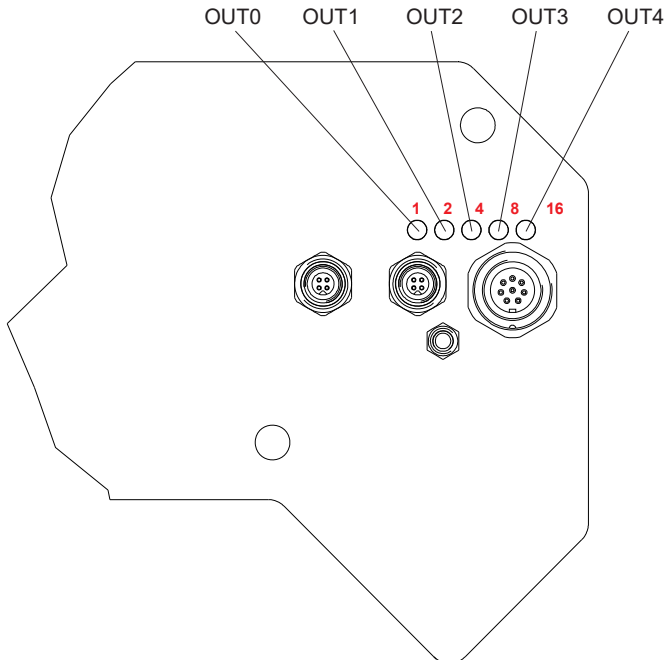



## Parameterization

### Windows® user interface:

(The current software version is available for download on our website.)

### Software COAST-Scope

The COAST sensor is parameterized under Windows® with the COAST-Scope software. The Windows® user interface facilitates the teach-in process at the color sensor and supports the operator in the task of adjustment and commissioning of the COAST sensor.

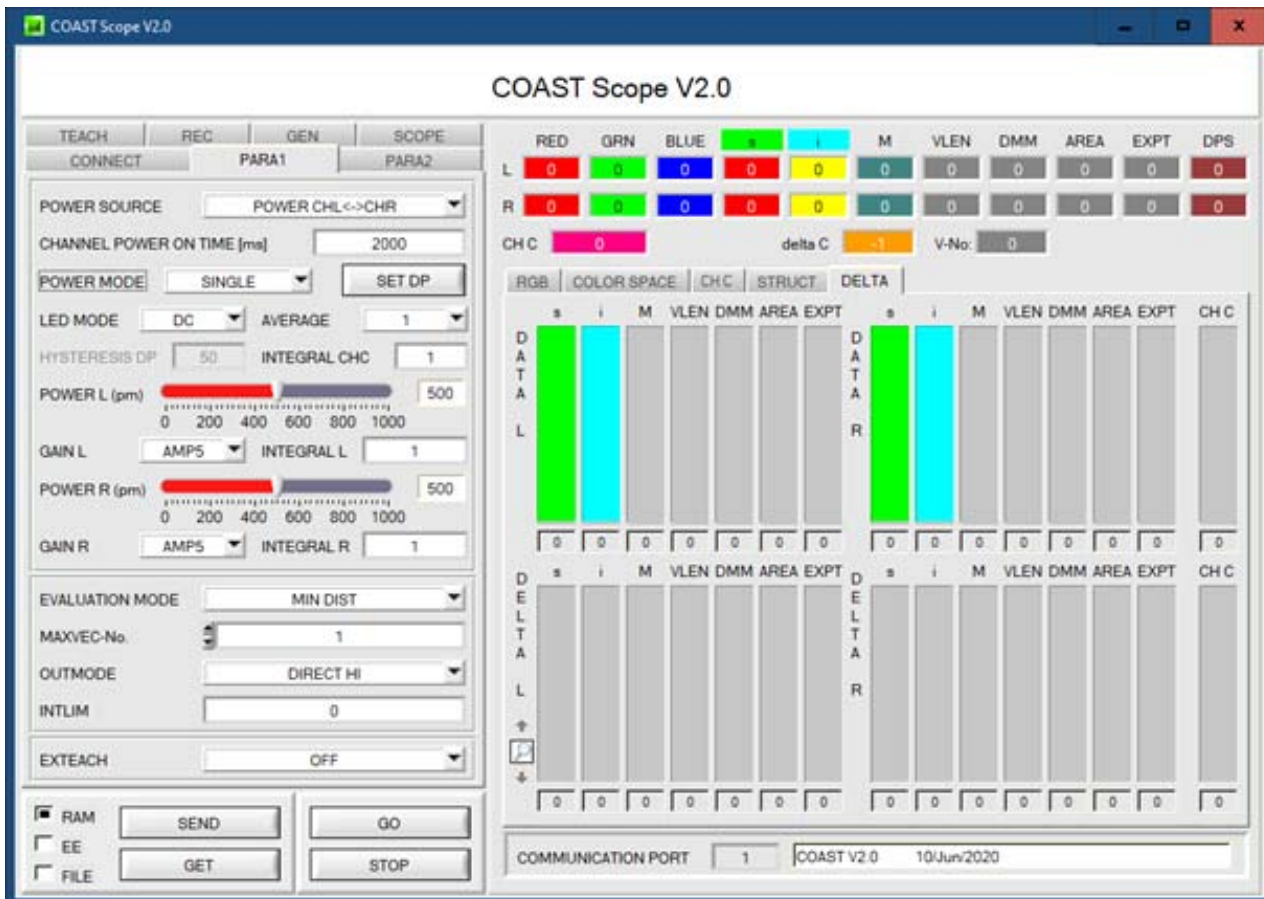

The RS232 interface (tab PARA1 or PARA2) is used for setting sensor parameters such as e.g.:

- POWER MODE: Light power of the LED
- LED MODE: Triggering of the internal light source (AC, DC)
- GAIN: Used for setting the gain of the color receiver (AMP1 ... AMP8)
- AVERAGE: Number of measurement values over which the raw signal measured at the color receiver is averaged
- INTEGRAL: Number of measurement values over which the raw signal measured at the color receiver is added up. The integral function allows even extremely weak signals to be reliably detected
- MAXVEC-No.: Number of surfaces (vectors) to be controlled
- OUTMODE: Control of the digital outputs
- INTLIM: Minimum intensity required for evaluation
- EXTEACH: It is possible to teach a vector externally via IN0 or via the button on the sensor housing

The structure sensor is set at the factory so that it only has to be parameterized in exceptional cases. There is also an own software "COAST-STRUCT-Scope".



**Parameterization**

**Software COAST-Scope: TEACH-TABLE**



**TEACH-TABLE:**  
 The sensors of the COAST series can be taught up to 31 surfaces, hereinafter referred to as teach vectors or vectors, that are provided directly at the outputs, and up to 64 vectors that are output by means of grouping.  
 The vector is output which deviates the least from the current surface (minimum distance).



**Firmware Update**

**Firmware update by means of the software „FirmwareLoader“:**

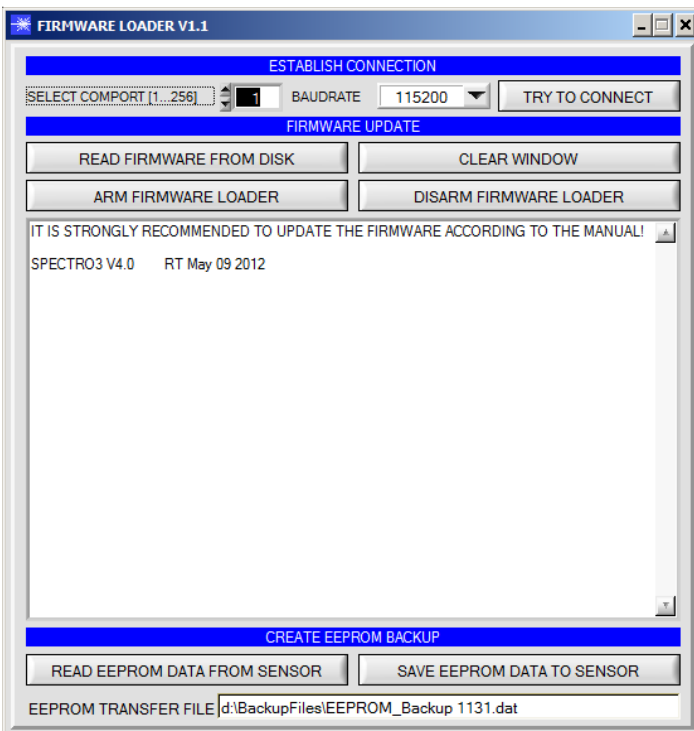

The software „Firmware Loader“ allows the user to perform an automatic firmware update. The update will be carried out through the RS232 interface.

An initialisation file (xxx.ini) and a firmware file (xxx.elf.S) are required for performing a firmware update. These files can be obtained from your supplier. In some cases an additional firmware file for the program memory (xxx.elf.p.S) is also needed, and this file will be automatically provided together with the other two files.



## Parameterization

### Software COAST-STRUCT-Scope

The COAST-STRUCT-Scope software is used to parameterise the control unit for the control/evaluation of the COAST (STRUCT) sensor. The PC software visualises the measurement values that are provided by the sensor. It can therefore, among others, be used to select a suitable evaluation algorithm and to set tolerance limits for the inspection of the measurement object.

Data exchange between the PC user interface and the sensor system is effected through a standard RS232 interface. For this purpose the sensor is connected to the PC with the serial interface cable cab-las-4/PC or with the USB cable cab-4/USB. When parameterisation is finished, the setting values can be permanently saved in an EEPROM memory of the COAST (STRUCT) control unit. The COAST (STRUCT) sensor then continues to operate in "STAND-ALONE" mode without the PC.

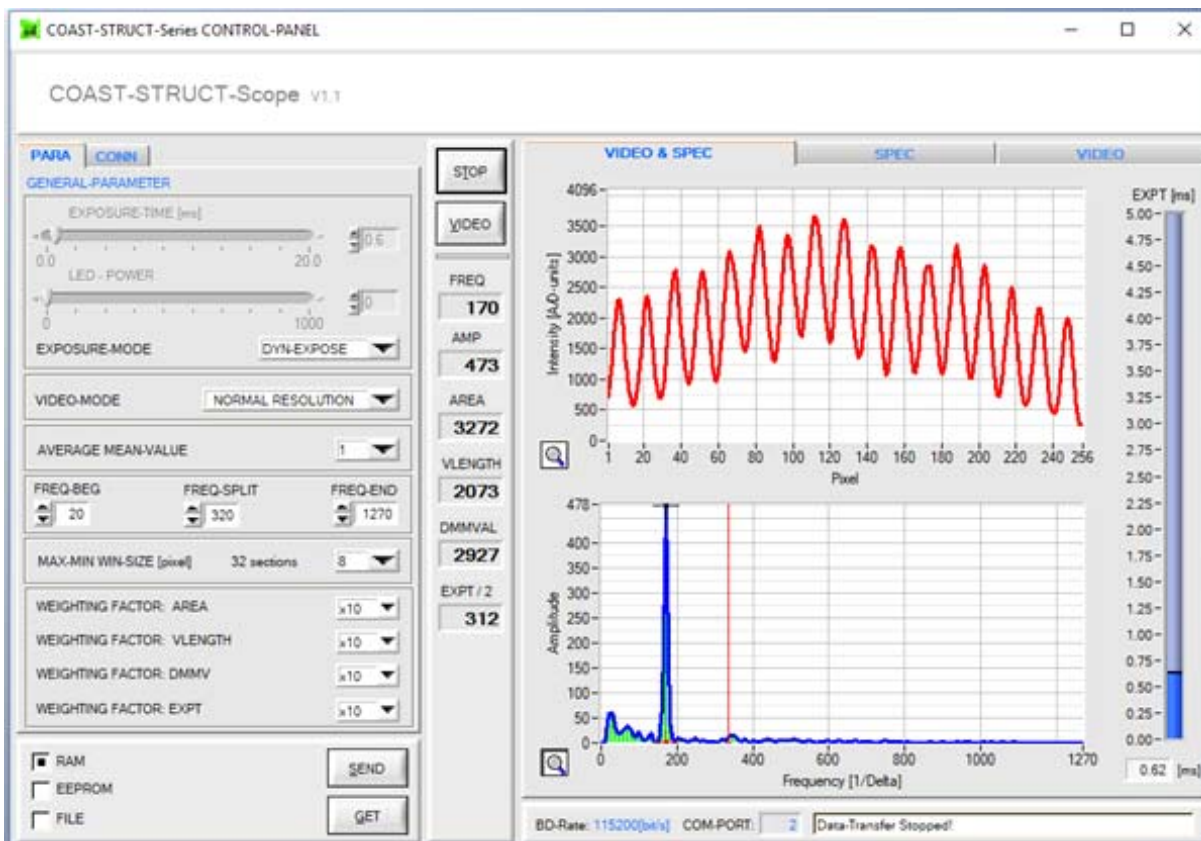

The COAST-STRUCT-Scope CONTROL-PANEL provides a large variety of functions:

- Visualisation of measurement data in numeric and graphic output fields.
- Setting of the light source/exposure-time.
- Selection of a suitable evaluation mode.
- Saving of parameters in the RAM / EEPROM memory of the control unit or in a configuration file on the PC's hard disk.



Accessories

**COAST-52-45°-OFL**  
**Top part for optics (spacer)**  
 (please order separately)

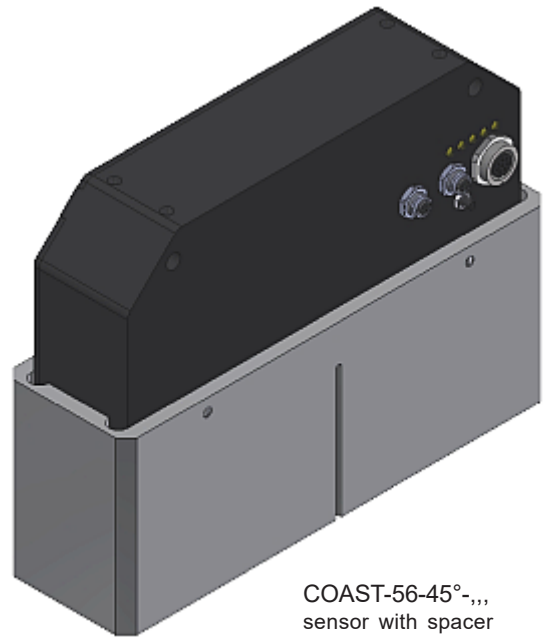
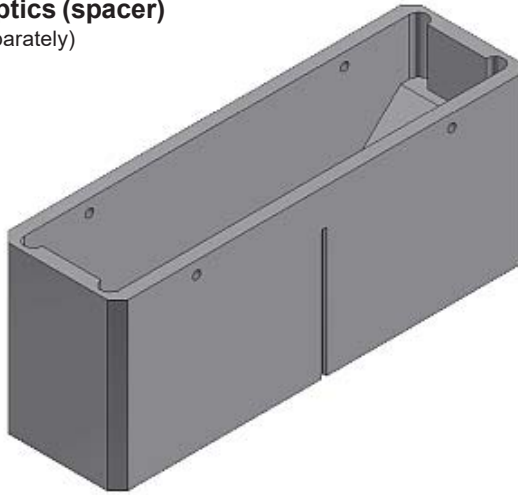

COAST-56-45°-,,,  
 sensor with spacer  
 COAST-52-45°-OFL

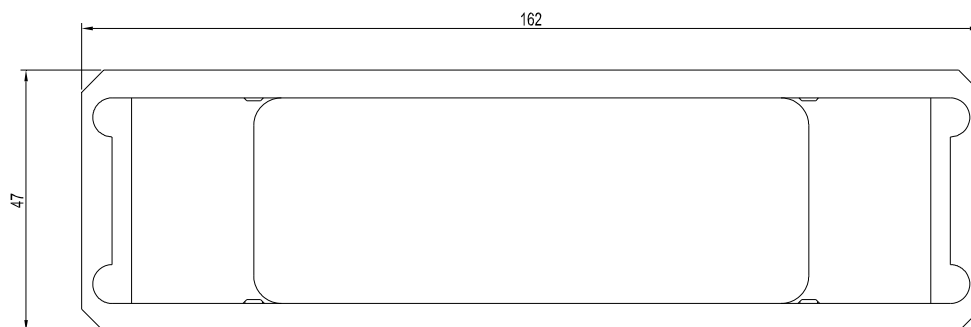
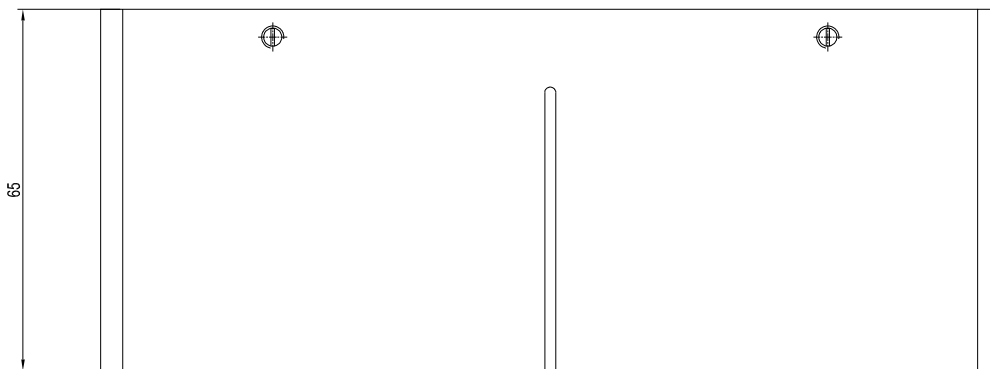
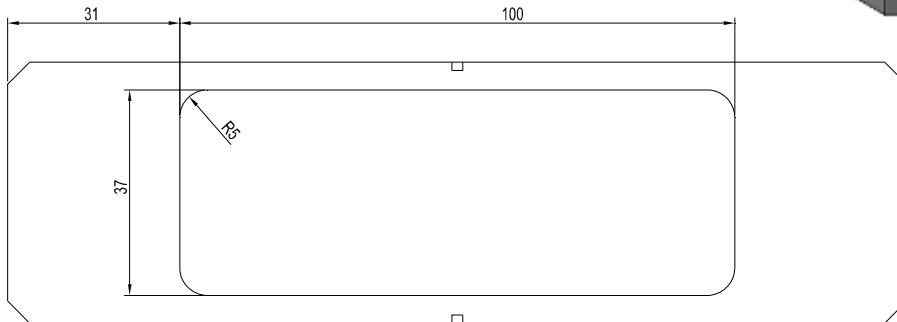

Alle Abmessungen in mm