

In Proud Partnership with Sensor Instruments



A-LAS-N Series

▶ A-LAS-N-12/90-...-C

- Analog signal (0...+10V or 4...20mA) in connection with an electronic control unit type SPECTRO-1-CONLAS (contrast measurement) or SPECTRO-2-CONLAS (stand-alone operation of the light barrier is not possible, i.e. operation without electronic control unit is not possible)
- Parallel aligned, visible red laser beam (<0.39 mW, 670 nm), **laser class 1**
- Various apertures available
- Measuring range up to 6.5 mm (depends on aperture)
- Working range max. 10 m (depends on aperture)
- Insensitive to outside light due to interference filter
- Compact design, sturdy metal housing, IP67

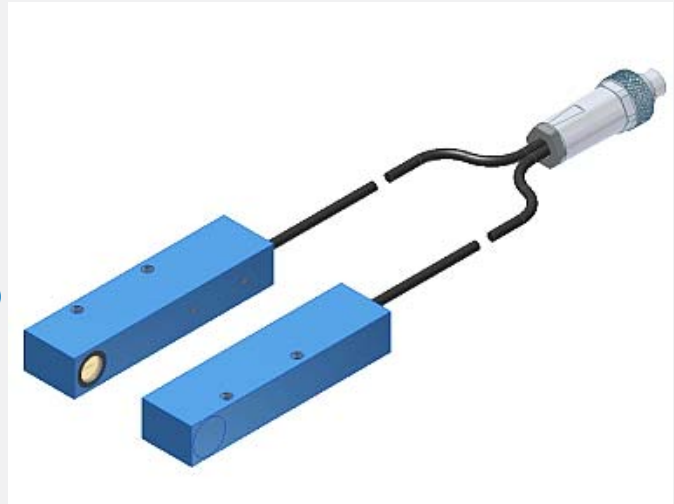

Design

Product name:

A-LAS-N-12/90-(aperture)*-C-(cable length)**

(consists of transmitter and receiver, incl. cable with 7-pole circular connector 712)

*Available apertures:

Round apertures d... (mm):

- d0.15
- d0.2
- d0.3
- d0.5
- d0.7
- d1.0
- d2.0
- d3.0

Rectangular apertures AxB (mm)

- | | |
|---------|---------|
| 0.2x1 | 1x4 |
| 0.3x0.5 | 1x5 |
| 0.3x0.8 | 1.2x2 |
| 0.3x1 | 1.5x0.3 |
| 0.3x1.5 | 2x0.75 |
| 0.3x3 | 2x1.2 |
| 0.5x0.3 | 2x1 |
| 0.5x1 | 2x3 |
| 0.5x4 | 2x6 |
| 0.5x6.5 | 3x0.3 |
| 0.75x2 | 3x0.75 |
| 0.75x3 | 3x2 |
| 0.75x5 | 4x0.5 |
| 0.8x0.3 | 4x1 |
| 0.8x6.5 | 5x0.75 |
| 1x0.2 | 5x1 |
| 1x0.3 | 6x2 |
| 1x0.5 | 6.5x0.5 |
| 1x1 | 6.5x0.8 |
| 1x2 | |

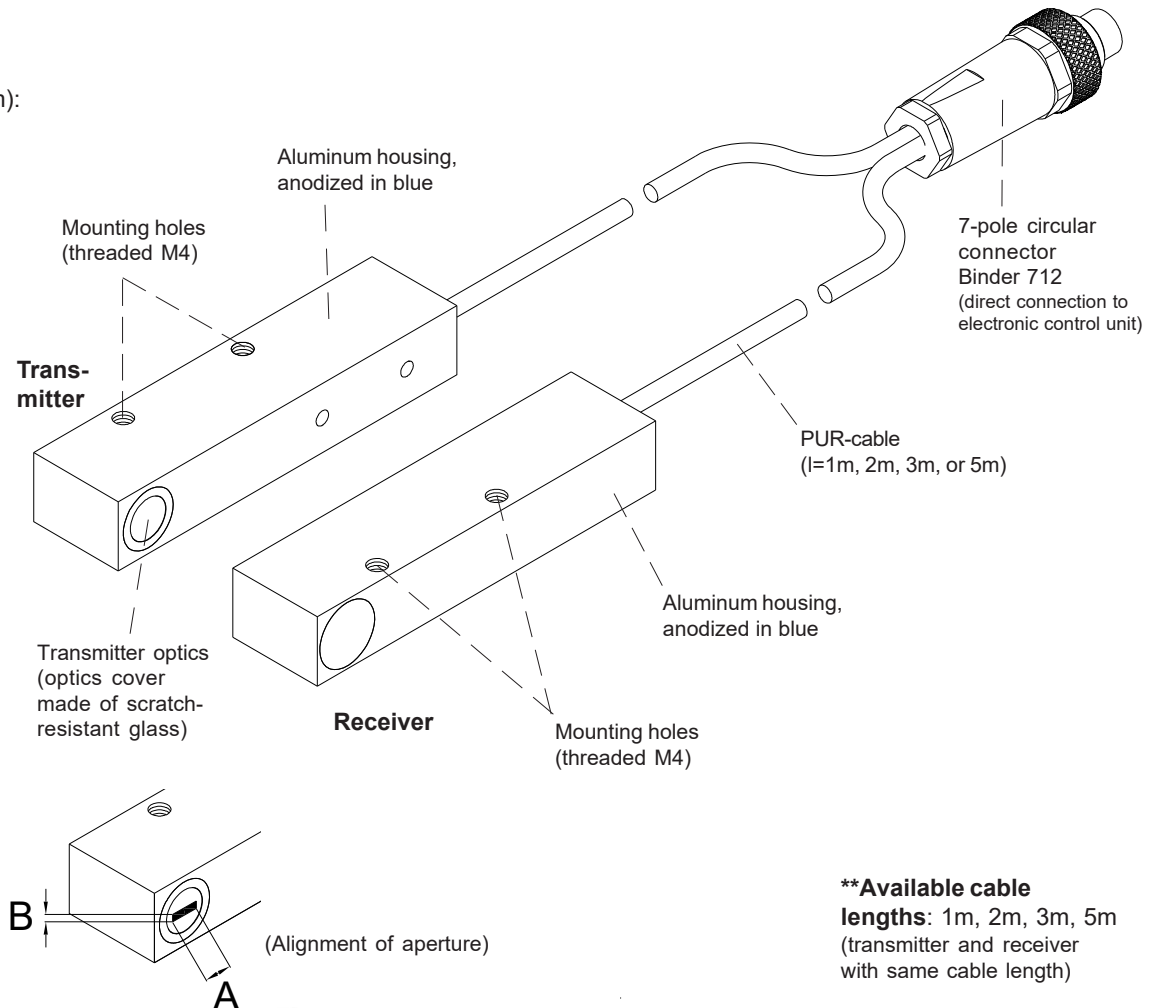

****Available cable lengths:** 1m, 2m, 3m, 5m (transmitter and receiver with same cable length)



Technical Data

Type	A-LAS-N-12/90-...-C
Shape	Split laser light barrier in rectangular housing. Various round and rectangular apertures are available.
Laser	Solid-state laser, 670 nm, DC-operation, 0.39 mW max. opt. power, laser class 1 acc. to DIN EN 60825-1. The use of these laser transmitter therefore requires no additional protective measures.
Available aperture sizes	cf. page 1
Measuring range	up to 6.5 mm (depends on the aperture used)
Working range	max. 10 m (depends on the aperture used and on cable length)
Min. detectable object	typ. 0.8% of aperture size
Threshold correction	can be activated via a software-controlled electronics of type SPECTRO-1-CONLAS or SPECTRO-2-CONLAS
Reproducibility	typ. 0.8% of aperture size, with threshold correction (via electronic control unit SPECTRO-1-CONLAS or SPECTRO-2-CONLAS): typ. 0.1% of aperture size
Optical filters	red light filter RG 630 and interference filter
Voltage supply	transmitter: +5VDC, receiver: +5VDC
Ambient light (outside light)	with 5000 Lux ambient light around optical receiver unit typ. < 300mV influence on analog signal (0...+10V)
Analog output (1x)	voltage 0 ... +10V or current 4...20mA in connection with an electronic control unit SPECTRO-1-CONLAS or SPECTRO-2-CONLAS
Band width analog signal	100 kHz (-3 dB)
Sensitivity setting (switching threshold)	via software-controlled electronics of type SPECTRO-1-CONLAS or SPECTRO-2-CONLAS
Gain (analog signal)	via software-controlled electronics of type SPECTRO-1-CONLAS or SPECTRO-2-CONLAS
Current consumption	transmitter: typ. 50 mA, receiver typ. 20 mA
Operating temperature range	0°C ... +50°C
Storage temperature range	-20°C ... +85°C
Type of connector	7-pole circular connector type Binder 712
Cable length	max. 5m
Housing material	aluminum, anodized in blue
Housing dimensions	transmitter and receiver: each LxWxH approx. 68 mm x 12 mm x 17 mm
Enclosure rating	IP67
EMC test acc. to	DIN EN 60947-5-2



Dimensions

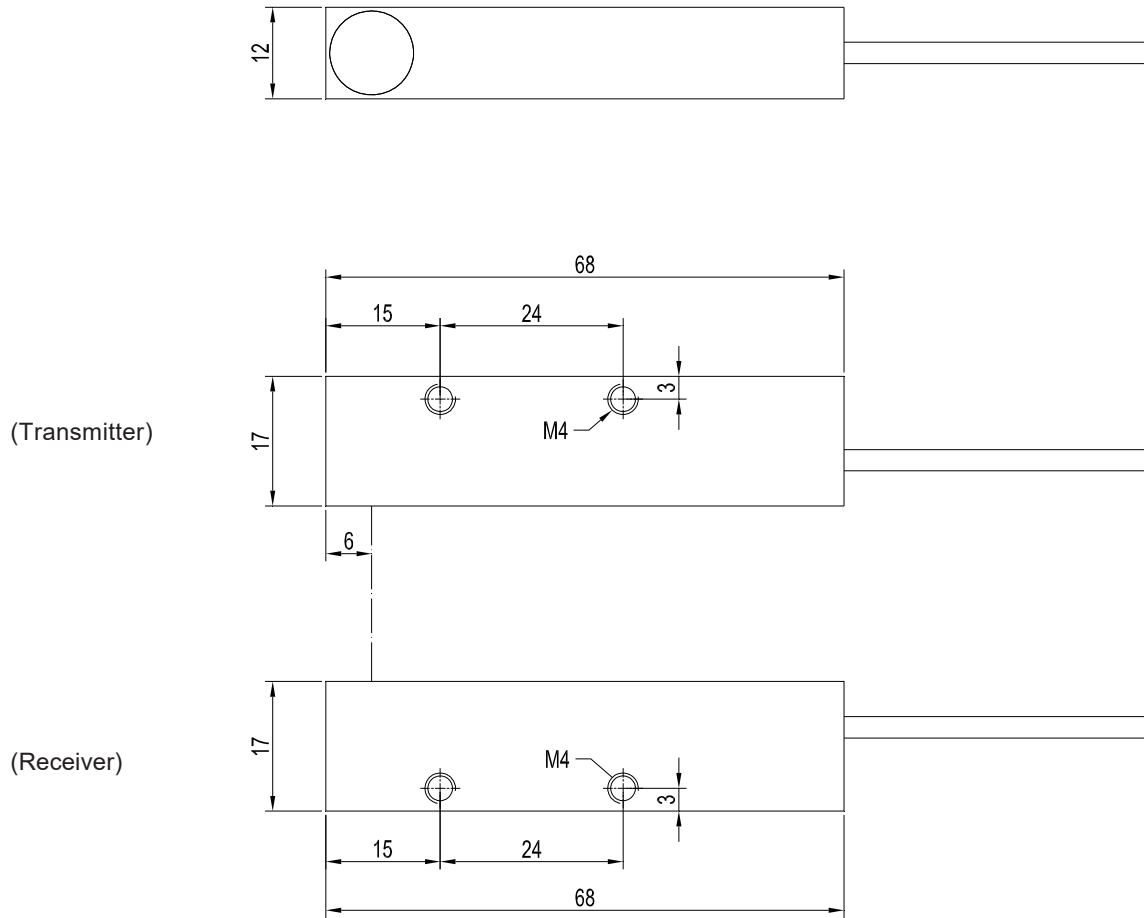

All dimensions in mm



Laser Information

The following applies to the use of laser sensor front ends of the A-LAS-N-...-C series in conjunction with the SPECTRO-1-CONLAS or SPECTRO-2-CONLAS electronic control unit:

The laser transmitters of A-LAS-N-...-C series comply with laser class 1 according to EN 60825-1. Under reasonably foreseeable conditions a class 1 laser is safe. The reasonably foreseeable conditions are kept during specified normal operation. The use of these laser transmitters therefore requires no additional protective measures.

The laser transmitters of A-LAS-N-...-C series series are supplied with an information label „CLASS 1 Laser Product“.



Class 1 Laser Product
 IEC 60825-1: 2014
 P<0.39 mW; λ=670 nm
 COMPLIES WITH 21 CFR 1040.10 AND 1040.11
 EXCEPT FOR CONFORMANCE WITH IEC 60825-1
 ED. 3, AS DESCRIBED IN
 LASER NOTICE NO. 56, DATED MAY 8, 2019.

 Connector Assignment

Connection to electronic control unit
SPECTRO-1-CONLAS or SPECTRO-2-CONLAS
by means of a 7-pole circular connector Binder 712:

Pin No.:	Assignment:
1	GND (0V)
2	+5V
3	Intensity
4	+5V
5	ANALOG
6	Clock
7	GND (0V)

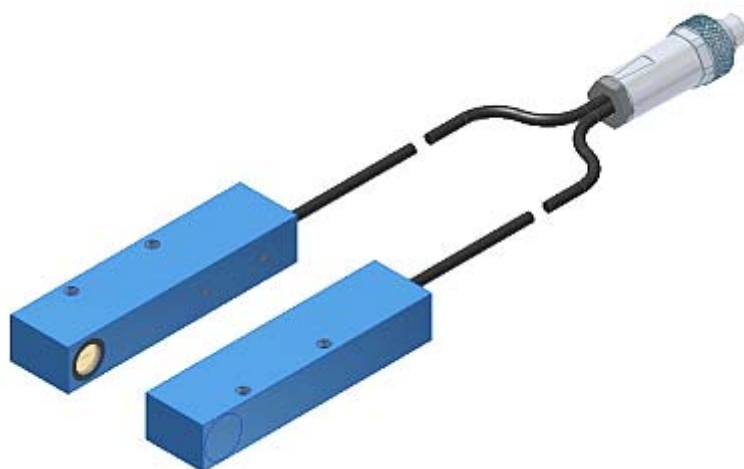
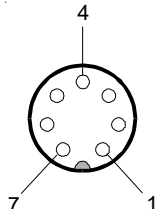

Connection directly to an electronic control unit of type
SPECTRO-1-CONLAS bzw. SPECTRO-2-CONLAS

Available optionally

Extension cable

cab-las7/712-fem-male-...

(cable length 1m, 2m, 3m, 4m)

Please note:

Max. total length of the cable (A-LAS-N-...-C + extension cable) is 5m

 Extension Cable

Available optionally:
Extension cable for sensor frontends of the A-LAS-N-...-C series
cab-las7/712-fem-male-(cable length)*

7-pole circular connector Binder 712:

Pin No.:	Assignment:
1	0V (GND)
2	+5V
3	Intensity
4	+5V
5	ANALOG
6	Clock
7	0V (GND)

Serves to extend the integrated connection cable of an already existing
sensor front end of the type A-LAS-N-...-C series to the control electronics
control electronics SPECTRO-1-CONLAS or SPECTRO-2-CONLAS
*Cable length 1m, 2m, 3m, 4m

Please note:

The total cable length of A-LAS-N-...-C + extension cable
must not exceed 5m:

A-LAS-N-...-C-1m (= length 1m) + cab-las7/712-fem-male-(...) length max. 4m
A-LAS-N-...-C-2m (= length 2m) + cab-las7/712-fem-male-(...) length max. 3m
A-LAS-N-...-C-3m (= length 3m) + cab-las7/712-fem-male-(...) length max. 2m
A-LAS-N-...-C-4m (= length 4m) + cab-las7/712-fem-male-(...) length max. 1m
A-LAS-N-...-C-5m (= length 5m) // no extension cable cab-las7/712-fem-male-(...) permitted

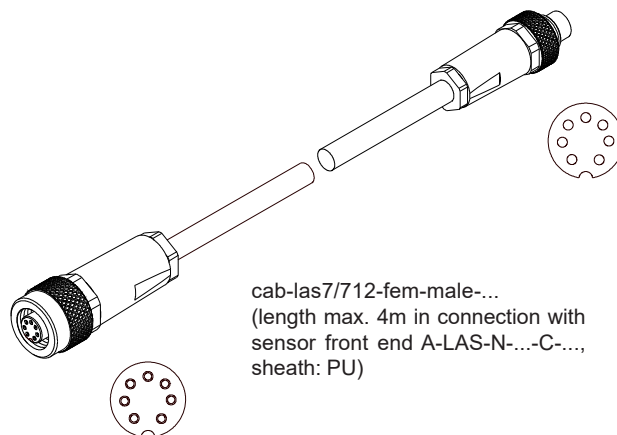

cab-las7/712-fem-male-...
(length max. 4m in connection with
sensor front end A-LAS-N-...-C-...,
sheath: PU)



Electronic Control Unit

Electronic control unit SPECTRO-1-CONLAS with Windows® software SPECTRO1-Scope

- Electronic control unit for control of laser sensor frontends of A-LAS-N-...-C Series or FK-...-LAS-IR Series
- High scan frequency
- Gray scale detection (12-bit resolution)
- Insensitive to outside light (in AC-operation)
- Brightness correction can be activated (STAT/DYN)
- Averaging can be activated (from 1 up to over 32000 values)
- Teach via PC or PLC
- 2 digital inputs (0V/+Ub)
- 2 digital outputs (max. 60 kHz switching frequency)
- 1 analog output (0V...+10V or 4...20mA), selectable via software
- Switching state indication by means of 2 yellow LEDs
- RS232 interface (USB or ETHERNET converter available)
- Parameterizable via Windows® software, scope function
- Temperature compensated (from 0°C to 60°C)
- Automatic threshold correction can be activated
- Switching threshold can be parameterized relative or absolute
- Various switching threshold functions (window, upper/lower threshold)

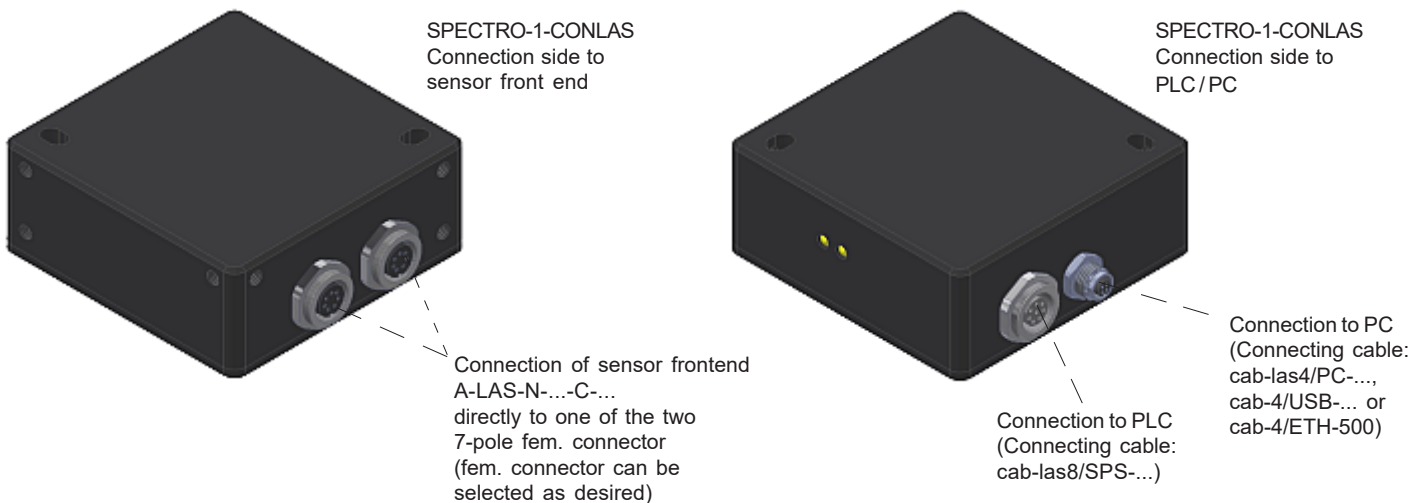



Electronic Control Unit

Electronic control unit SPECTRO-2-CONLAS with Windows® software SPECTRO2-Scope

- Electronic control unit for controlling up to two laser sensor frontends of the A-LAS-N-...-C series or FK-...-LAS-IR Series
- Wide range of applications
- Various evaluation modes available:
Distance measurement (BICONE),
contrast comparison (NORM),
2-channel contrast control
- Fast evaluation methods in DC-operation available
(up to 130kHz)
- Insensitive to outside light (in AC-operation)
- Parameterizable via Windows® software
- RS232 interface (RS232/Ethernet converter and
RS232/USB converter available)
- Suitable for use in hazardous areas (fiber optics)
- 1 analog output (0V... +10V or 4mA...20mA), selectable via software
- 2 digital outputs (0V/+24V)
- External trigger input and teach input
- Linearization by means of an editable linearization curve

