

A-LAS Series

▶ A-LAS-F08

- Analog signal (0...+10V) in connection with an electronic control unit type AGL3, AGL4, AGL4-HS, AGL-DIF, SI-CON11 (without PC connection) or SI-CON4, SI-CON8, SI-CON34, A-LAS-CON1 (with PC connection and software)
(stand-alone operation of the light barrier is not possible)
- Parallel aligned, visible red laser beam (<0.39 mW, 670 nm), **laser class 1**
- Various apertures and fork sizes available
- Measuring range up to 3 mm (depends on aperture used)
- Working range = fork width
- Insensitive to outside light due to interference filter
- Compact design, sturdy metal housing, IP67

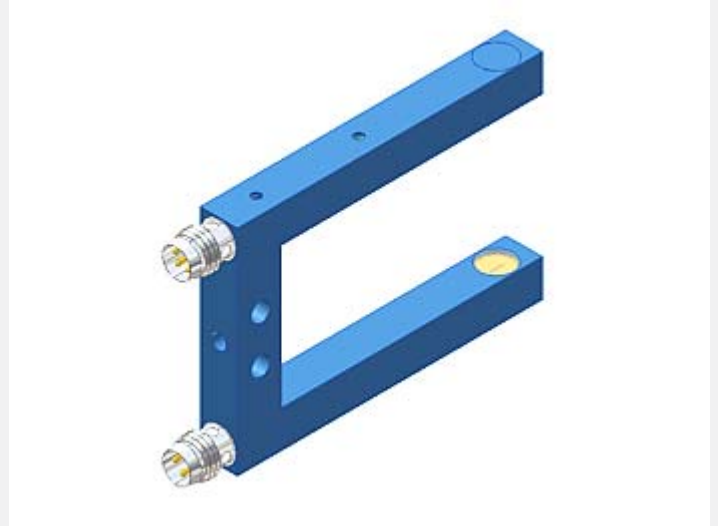

Design

Product name:

A-LAS-F08-(aperture)*-(fork size)**

***Available apertures:**

Round apertures

d... (mm):

- d0.15
- d0.2
- d0.3
- d0.5
- d0.7
- d1.0
- d2.0

Rectangular apertures

AxB (mm):

- 0.2x0.5 1.5x0.3
- 0.2x1 2x0.5
- 0.3x0.5 2x0.75
- 0.3x0.8 2x1
- 0.3x1 3x0.5
- 0.3x1.5 3x0.75
- 0.5x0.2 3x1
- 0.5x0.3
- 0.5x1
- 0.5x2
- 0.5x3
- 0.75x2
- 0.75x3
- 0.8x0.3
- 1x0.2
- 1x0.3
- 1x0.5
- 1x1
- 1x2
- 1x3

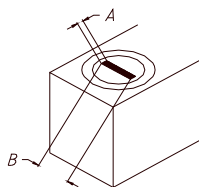
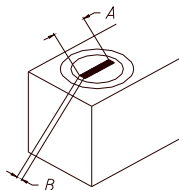

****Available fork sizes:**

Fork size

Fork size	Fork width (mm)	Fork depth (mm)
10/50	10	50
20/50	20	50
20/60	20	60
20/80	20	80
30/50	30	50
30/60	30	60
30/80	30	80
40/50	40	50
40/60	40	60
40/80	40	80
50/50	50	50
50/60	50	60
50/80	50	80
100/50	100	50
100/80	100	80

A-LAS-F08-...-10/50 (only fork size 10/50)

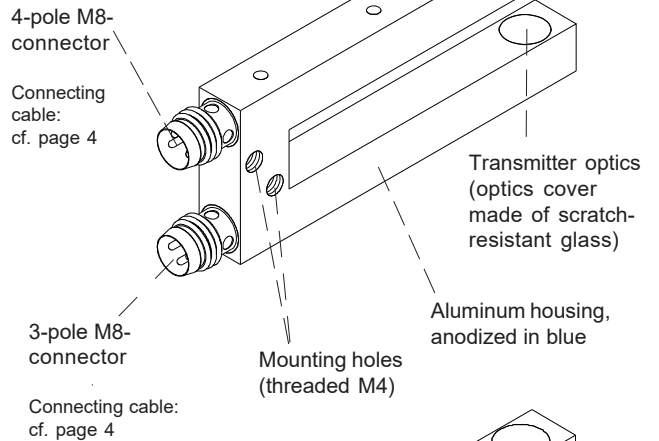

A-LAS-F08-... from fork size 20/50:

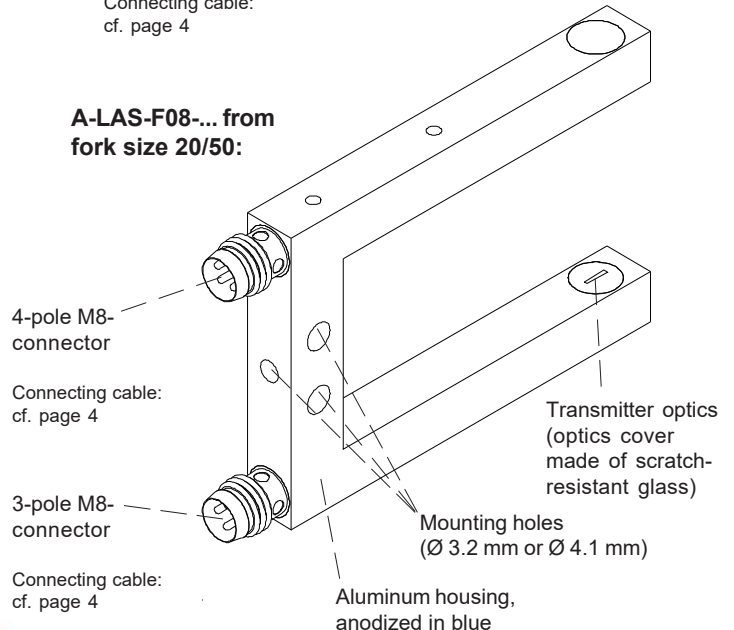



Technical Data

Type	A-LAS-F08
Shape	Laser light barrier in fork shape with 8 mm thick housing. Various round or rectangular apertures are available.
Laser	Solid-state laser, 670 nm, DC-operation, 0.39 mW max. opt. power, laser class 1 acc. to DIN EN 60825-1. The use of these laser transmitter therefore requires no additional protective measures.
Available aperture sizes	Cf. page 1
Measuring range	Up to 3 mm (depends on the aperture used)
Working range	Working range = fork width
Min. detectable object	Typ. 1% of aperture size
Reproducibility	Typ. 1% of aperture size, with threshold correction (via electronic control unit): typ. 0.1% of aperture size
Threshold correction	Can be activated via a software-controlled electronics of type A-LAS-CON1, SI-CON4, SI-CON8, or SI-CON34
Optical filters	Red light filter RG 630 and interference filter
Voltage supply	Transmitter: +5VDC, receiver: +5VDC
Ambient light (outside light)	With 5000 Lux ambient light around optical receiver unit typ. < 300mV influence on analog signal (0...+10V)
Analog output	0 ... +10V (in connection with any electronic control unit of A-LAS Series)
Band width analog signal	100 kHz (-3 dB)
Current control input (I-CONTROL)	0V ... 5V, laser power decreases linear to increase of voltage: 0V: full power, 5V: laser off
Sensitivity setting (switching threshold)	Via software (with control electronics A-LAS-CON1, SI-CON4, SI-CON34, or SI-CON8) or via potentiometer (with control electronics AGL4 or AGL4-HS)
Gain (analog signal)	Via software (with control electronics A-LAS-CON1, SI-CON4, SI-CON34, or SI-CON8) or via potentiometer (with control electronics AGL4, AGL4-HS, AGL-DIF, or SI-CON11)
Current consumption	Transmitter: typ. 50 mA, receiver typ. 20 mA
Operating temperature range	0°C ... +50°C
Storage temperature range	-20°C ... +85°C
Type of connector	Transmitter: 3-pole M8-connector, receiver: 4-pole M8-connector
Housing material	Aluminum, anodized in blue
Housing dimensions	Cf. page 3
Enclosure rating	IP67
EMC test acc. to	DIN EN 60947-5-2 



Laser Information

The laser transmitters of A-LAS series comply with laser class 1 according to EN 60825-1. Under reasonably foreseeable conditions a class 1 laser is safe. The reasonably foreseeable conditions are kept during specified normal operation. The use of these laser transmitters therefore requires no additional protective measures.

The laser transmitters of A-LAS series series are supplied with an information label „CLASS 1 Laser Product“.



Class 1 Laser Product
IEC 60825-1: 2014
P<0.39 mW; λ=670 nm
COMPLIES WITH 21 CFR 1040.10 AND 1040.11
EXCEPT FOR CONFORMANCE WITH IEC 60825-1
ED. 3, AS DESCRIBED IN
LASER NOTICE NO. 56, DATED MAY 8, 2019.

Dimensions

A-LAS-F08-...-10/50:

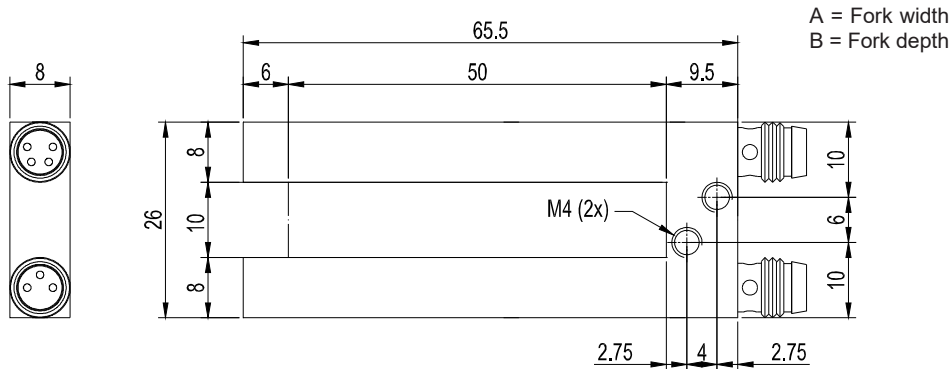

Size	Fork width A (mm)	Fork depth B (mm)
10/50	10	50

A-LAS-F08-... from fork size 20/50:

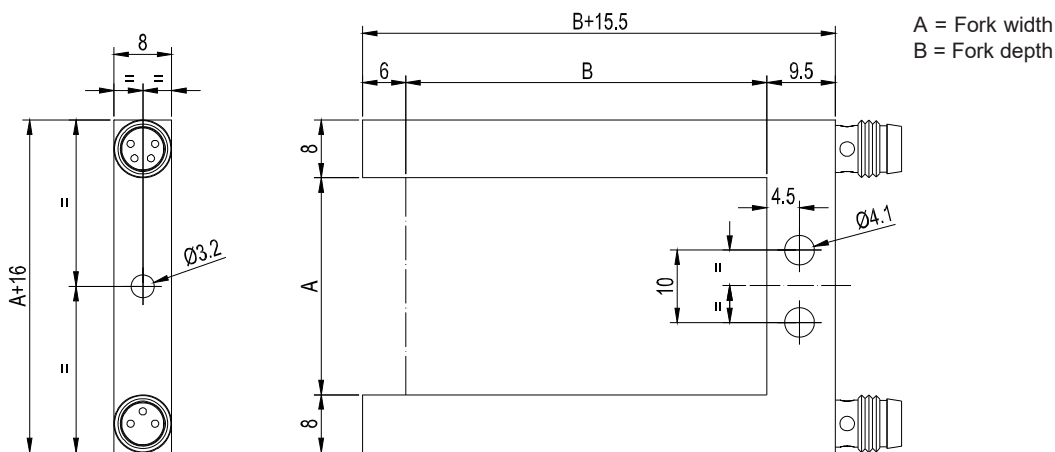

Size	Fork width A (mm)	Fork depth B (mm)
20/50	20	50
20/60	20	60
20/80	20	80
30/50	30	50
30/60	30	60
30/80	30	80
40/50	40	50
40/60	40	60
40/80	40	80
50/50	50	50
50/60	50	60
50/80	50	80
100/50	100	50
100/80	100	80

All dimensions in mm

Connector Assignment

Receiver: 4-pole M8-connector

Pin No.:	Assignment:
1	+5 VDC
2	GND (0V)
3	SHIELD
4	ANALOG

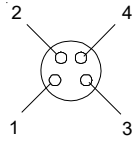

Transmitter: 3-pole M8-connector

Pin No.:	Assignment:
1	+5 VDC
3	GND (0V)
4	I-CONTROL (0V...+5V)

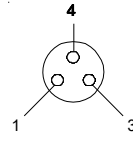

Connecting cables:

For use with SI-CON4:

cab-las3-(length) or cab-las3-w-(length) für transmitter
 cab-las4-(length) or cab-las4-w-(length) für receiver
 (standard length each 1m, also available lengths: 2m, 3m, or 5m)

For use with AGL4, AGL4-HS, AGL-DIF, SI-CON11, SI-CON8, SI-CON34, A-LAS-CON1:

cab-las-y-(length) or
 cab-las-y-w-(length)
 (standard length each 1m, also available lengths: 2m, 3m, or 5m)

For use with AGL3:

no connecting cable is necessary

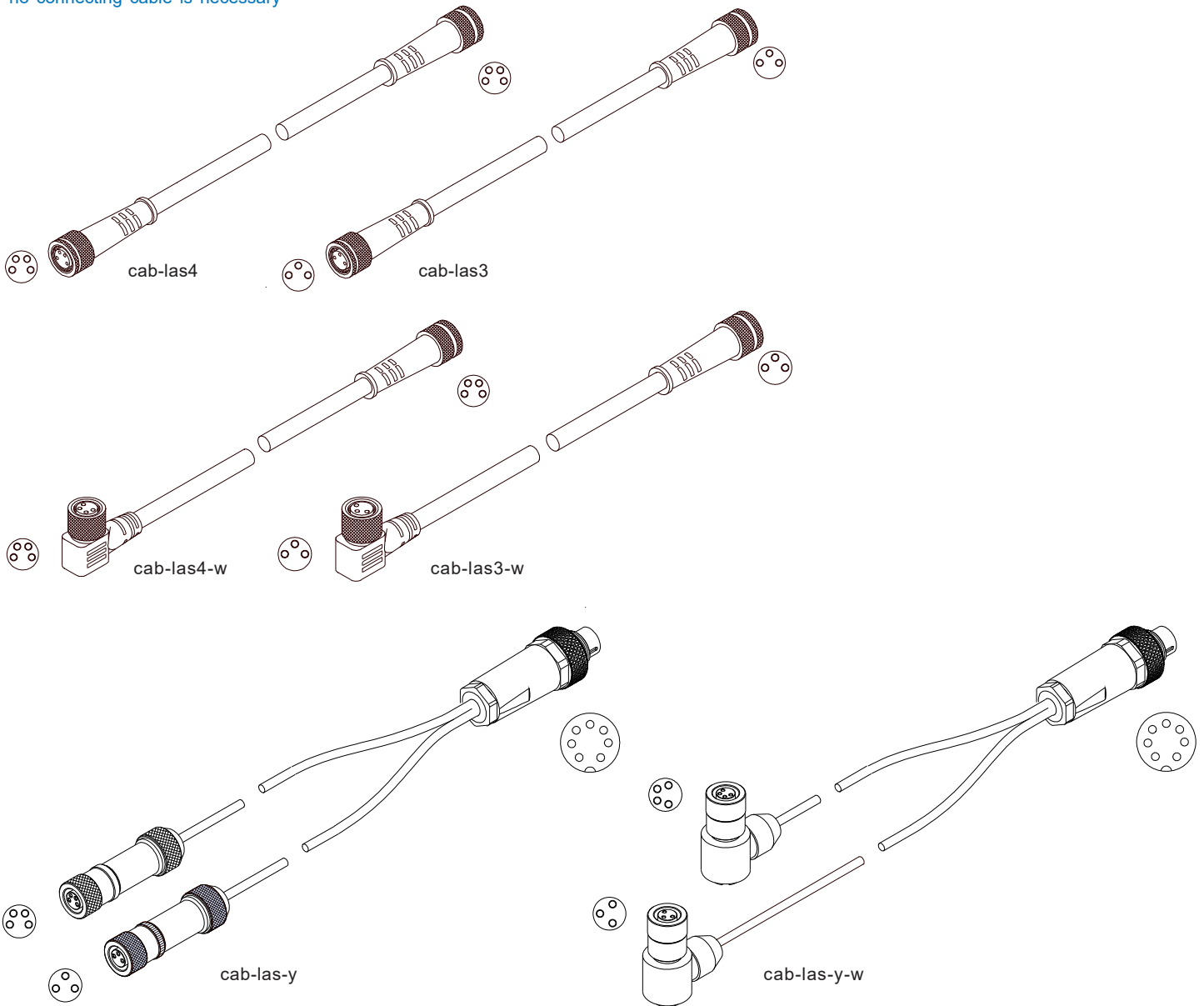

Electronic Control Units

Suitable electronic control units:

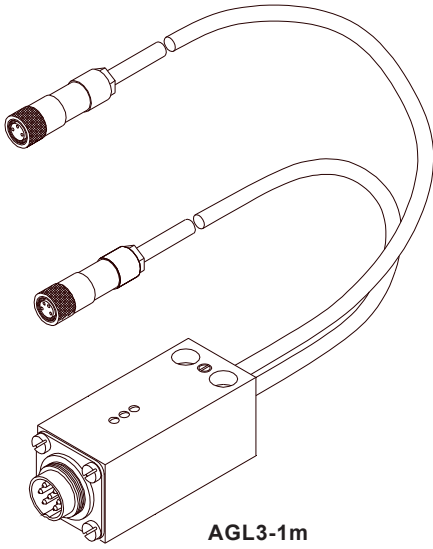

AGL3-1m
AGL3-2m
AGL3-3m
AGL3-4m
AGL3-5m

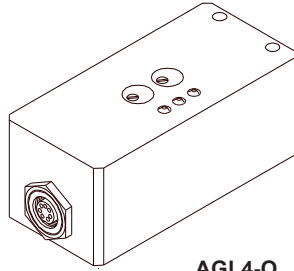

AGL4-Q
AGL4-Qinv
AGL4-Qinv-200ms

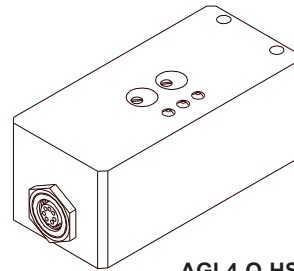

AGL4-Q-HS-500kHz-24V_LED
AGL4-Qinv-HS-500kHz-24V_LED

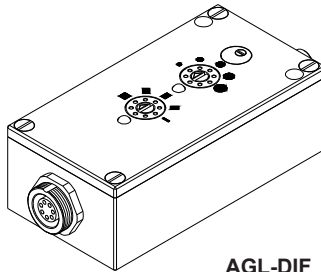

AGL-DIF

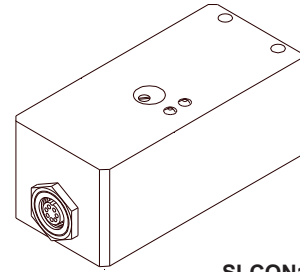

SI-CON11-0/20
SI-CON11-0/20-5V
SI-CON11-0/20-IC
SI-CON11-4/20
SI-CON11-4/20-IC
SI-CON11-5/25
SI-CON11-5/25-IC

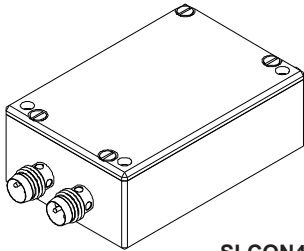

SI-CON4
(incl. Windows® PC software
A-LAS-Scope)

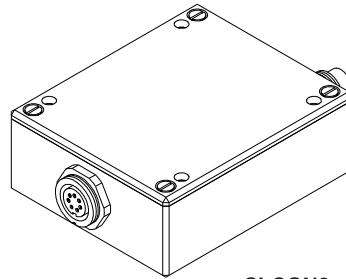

SI-CON8
(incl. Windows® PC software
SI-CON8-Scope)

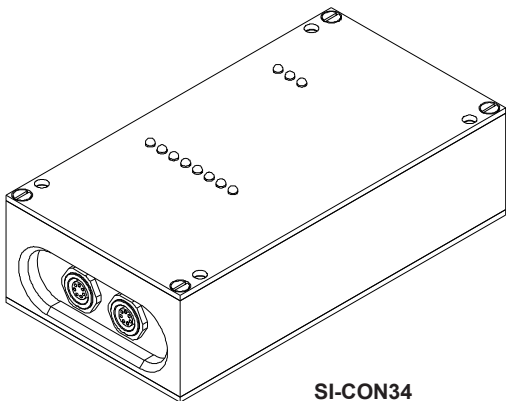

SI-CON34
(incl. Windows® PC software
SCOPE34)

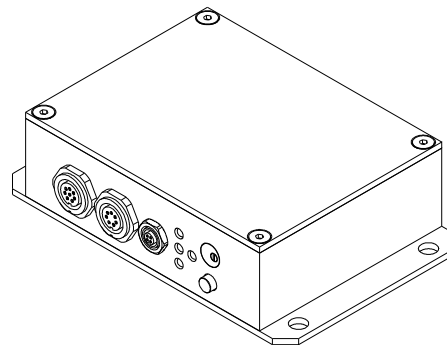

A-LAS-CON1
(incl. Windows® PC software
A-LAS-CON1-Scope)

