

A-LAS Series

▶ A-LAS-CON1 A-LAS-CON1-4/20

- Electronic control unit for control of max. two A-LAS sensors
- 100%-check of objects (tolerance band check)
- Object positioning and thickness control (in μm range)
- High trigger accuracy (in μm range)
- High switching frequency (max. 25 kHz)
- Setting of trigger threshold and tolerance band via Windows® software
- Output polarity can be switched via software
- Dirt accumulation compensation
- External teach push-button and potentiometer
- 2 digital inputs, 3 digital outputs
- 1 analog output (voltage 0 ... +10V or current 4 ... 20mA)
- Switching state indication by means of 4 LEDs

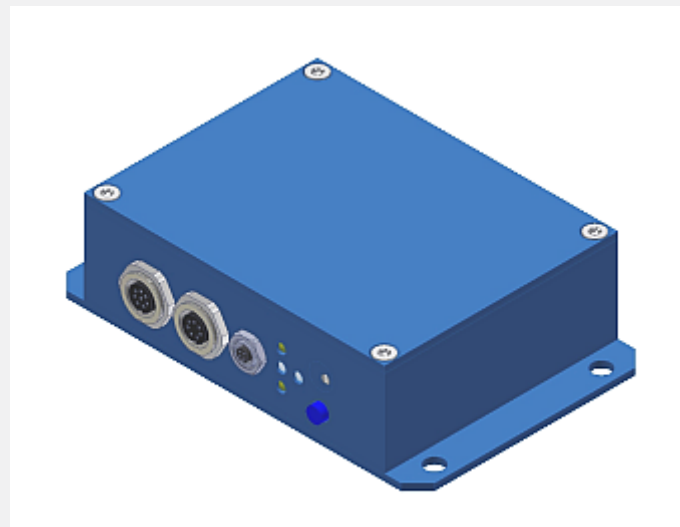

Design

Product name:

A-LAS-CON1 A-LAS-CON1-4/20

incl. Windows® PC software
A-LAS-CON1-Scope

4/20:

Analog output
4...20mA
(instead of
0...+10V)

8-pole fem. connector
Binder Series 712
(connection to PLC)

Connecting cable:
cab-las8/SPS

7-pole fem. connector
Binder Series 712
(data Slave/Master)
*not necessary for single
system, only for master/
slave system!*

Connecting cable:
cab-las7-male

4-pole fem. connector
Binder Series 707
(RS232 interface)

Connecting cable:
cab-las4/PC or
cab-4/USB or
cab-4/ETH

LED display:
yel, red/grn,
yel, yel/grn
(cf. page 6)

TEACH or RESET
push-button

Potentiometer

7-pole fem. connector
Binder Series 712
(A-LAS sensor CHA)

Connecting cable:
cab-las-y or
cab-las-y-male or
A-LAS-...-C directly

Sturdy aluminium housing,
anodized in blue

7-pole fem. connector
Binder Series 712
(A-LAS sensor CHB)

Connecting cable:
cab-las-y or
cab-las-y-male or
A-LAS-...-C directly

Mounting
holes

Sensor

Instruments



Technical Data

Model	A-LAS-CON1	A-LAS-CON1-4/20
Voltage supply	+24VDC \pm 10%, reversed polarity protected, short-circuit protected	
Current consumption	< 250 mA	
Min. detectable object	< 10 μ m (depends on the aperture of A-LAS sensor)	
Resolution	0,1% (100% = aperture size of A-LAS sensor)	
Operating temperature range	-20°C ... +55°C	
Storage temperature range	-20°C ... +85°C	
Enclosure rating	IP54	
Digital inputs (IN0, IN1)	IN0, IN1: Multi-purpose (trigger, teach, reset, ...), adjustable under Windows® Input voltage +Ub/0V, with protective circuit	
Digital outputs (OUT0, OUT1, OUT2)	OUT0, OUT1, OUT2: pnp bright-switching = pnp n.c. / npn dark-switching = npn n.o. or pnp dark-switching = pnp n.o. / npn bright-switching = npn n.c. (adjustable under Windows®, 100 mA, short-circuit protected)	
Analog output (1x)	voltage 0 ... +10V	current 4 ... 20mA
Band width analog signal	typ. 10 kHz (-3dB)	
Sensitivity setting	adjustable under Windows® via PC	
Housing material	aluminum, anodized in blue	
Housing dimensions	LxWxH approx. 110 mm x 70 mm x 30 mm	
Type of connector	8-pole fem. connector type Binder Series 712 (PLC/Power) 4-pole fem. connector type Binder Series 707 (PC/RS232) 7-pole fem. connector type Binder Series 712 (A-LAS sensor 1) 7-pole fem. connector type Binder Series 712 (A-LAS sensor 2) 8-pole fem. connector type Binder Series 712 (Data Master/Slave)	
TEACH push-button	Teach push button mounted at the housing for setting of norm value	
LED display	LED yellow : status output OUT1 LED red/green : status output OUT2 LED yellow : status output OUT0 LED yellow/green: voltage indication/visualization of teach process (multifunctional LED)	
EMC test acc. to	DIN EN 60947-5-2	
Switching frequency	max. 25 kHz	
Max. switching current	100 mA, short-circuit protected	
Interface	RS232, parameterizable under Windows®	
Connecting cables	to PC: cab-las4/PC or cab-las4/PC-w or cab-4/USB or cab-4/ETH to PLC: cab-las8/SPS or cab-las8/SPS-w to A-LAS sensor 1: cab-las-y or cab-las-y-male-1m to A-LAS sensor 2: cab-las-y or cab-las-y-male-1m necessary for Master/Slave operation: cab-las7-male	



Connector Assignment

Connection A-LAS-CON1 to PLC:

8-pole fem. connector Binder Series 712

Pin:	(Wire color):	Assignment:
1	(white)	GND (0V)
2	(brown)	+Ub (+24VDC ± 10%)
3	(green)	IN0 (Input 0V/+Ub)
4	(yellow)	IN1 (Input 0V/+Ub)
5	(grey)	OUT0 (Output 0V/+Ub)
6	(pink)	OUT1 (Output 0V/+Ub)
7	(blue)	OUT2 (Output 0V/+Ub)
8	(red)	ANA (0 ... +10V)

in case of type 4/20: ANA I_{OUT} (4 ... 20mA)

Connecting cable:
 cab-las8/SPS-(length) or
 cab-las8/SPS-w-(length) (angle type 90°)
 (Standard length 2m, available up to 25m)

Connection A-LAS-CON1 to PC:

4-pole fem. connector Binder Series 707

Pin:	Assignment:
1	+24VDC (+Ub, OUT)
2	GND (0V)
3	Rx0
4	Tx0

Connection via RS232 interface at the PC:

Connecting cable:
 cab-las4/PC-(length)
 cab-las4/PC-w-(length) (angle type 90°)
 (standard length 2m)

alternative:

Connection via USB interface at the PC:

Connecting cable (incl. driver software):
 cab-4/USB-(length)
 cab-4/USB-w-(length) (angle type 90°)
 (standard length 2m)

alternative:

Connection to local network via Ethernet bus:

Adapter (incl. software „SensorFinder“):
 cab-4/ETH-500
 (standard length 0.5m)
 Optional: External CAT5 cable, e.g.
 cab-eth/M12D-RJ45-flx-(length)

Connection of A-LAS sensor („sensor 1“ or „sensor 2“):

7-pole fem. connector Binder Series 712

Pin:	Assignment:
1	GND (0V)
2	+5V
3	I-CONTROL
4	+5V
5	ANALOG (0V ... +5V)
6	no operation
7	GND (0V)

Connecting cable*:
 cab-las-y-(length) respectively
 cab-las-y-male-(length)
 (standard length: 1m, also available 2m, 3m, 5m)

(* cable type depends on
 type of A-LAS sensor used)

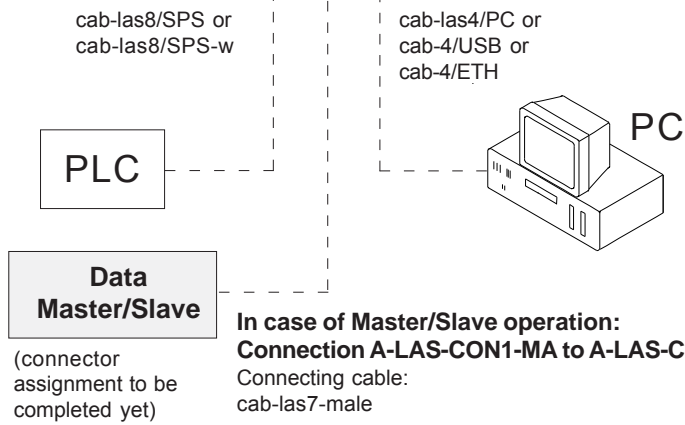
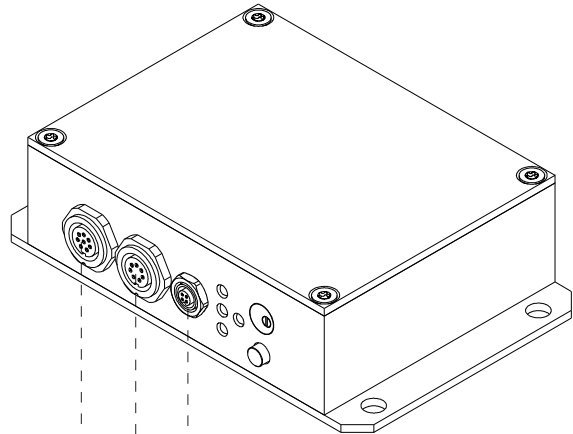

In case of Master/Slave operation:
Connection A-LAS-CON1-MA to A-LAS-CON1-SL
 Connecting cable:
 cab-las7-male

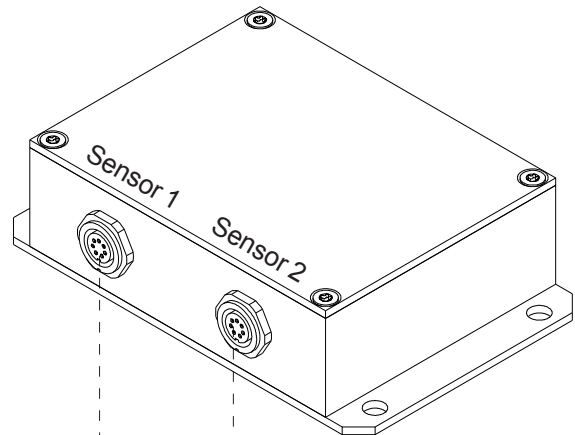

cab-las-y
 cab-las-y-male

**Connection A-LAS-CON1 to
 A-LAS Sensor 1**

cab-las-y
 cab-las-y-male

**Connection A-LAS-CON1 to
 A-LAS Sensor 2**



Connecting Cables

Connection A-LAS-CON1 to PLC:

Available cable types to choose from:

- cab-las8/SPS-2m
- cab-las8/SPS-5m
- cab-las8/SPS-10m
- cab-las8/SPS-25m
- or
- cab-las8/SPS-w-2m (angle type 90°)
- cab-las8/SPS-w-5m (angle type 90°)
- cab-las8/SPS-w-10m (angle type 90°)
- cab-las8/SPS-w-25m (angle type 90°)

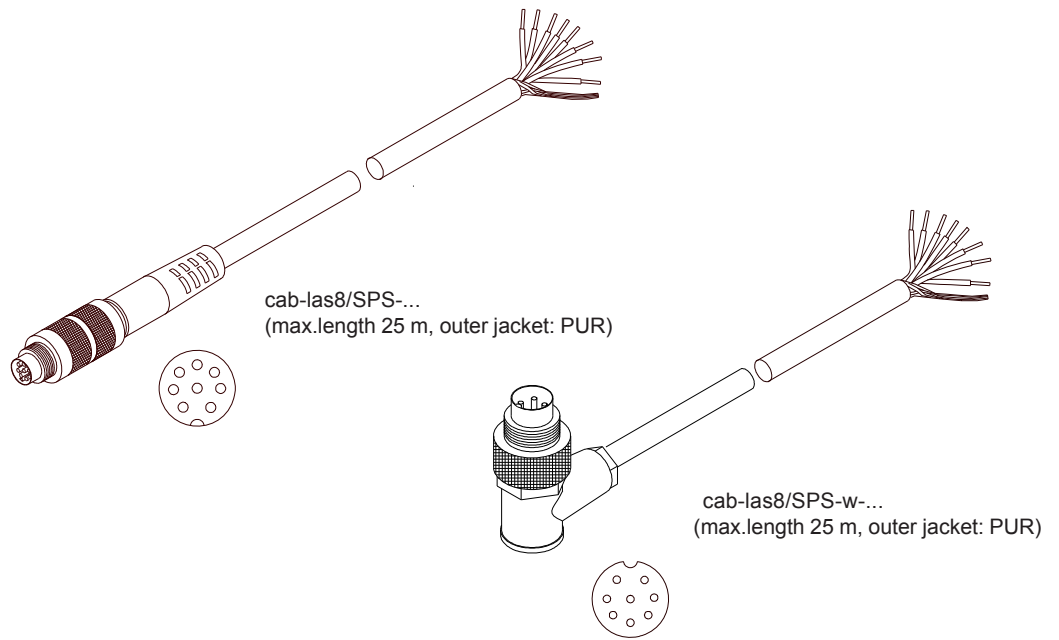

Connection A-LAS-CON1 to A-LAS sensor:

Connecting cable for A-LAS sensors with 3-pole/4-pole **male connector** Binder Series 712:

- cab-las-y-1m
- cab-las-y-2m
- cab-las-y-3m
- cab-las-y-5m

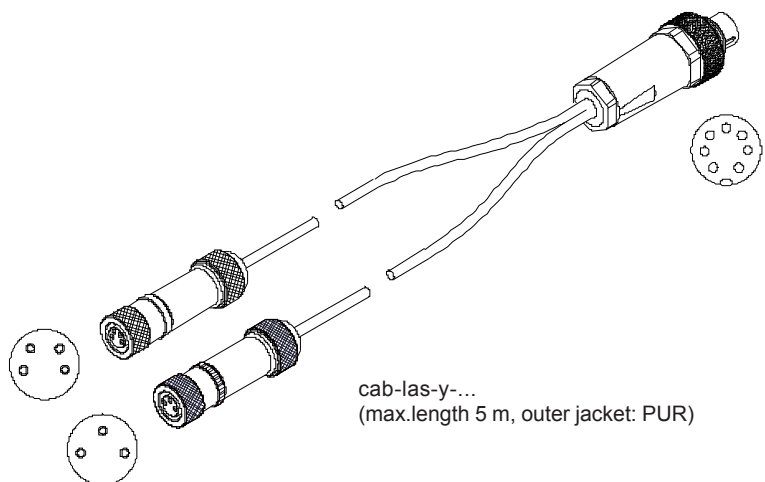

Connecting cable for A-LAS sensors with 3-pole/4-pole **female connector** Binder Series 712:

- cab-las-y-male-1m
- cab-las-y-male-2m
- cab-las-y-male-3m
- cab-las-y-male-5m

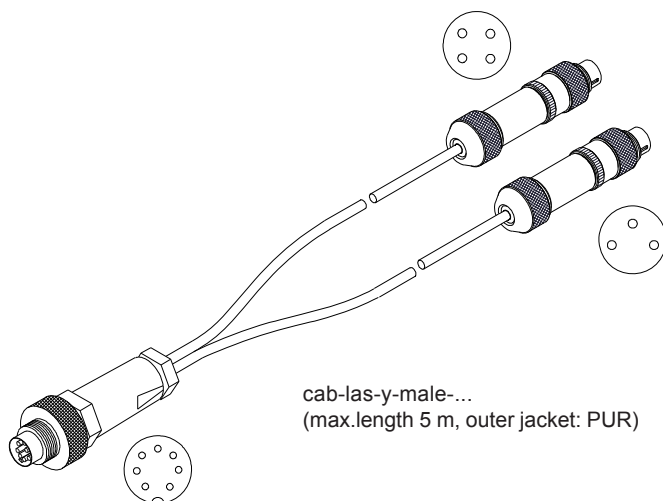

Connecting Cables

Connection A-LAS-CON1 to PC:

Available cable types to choose from:
 cab-las4/PC-...
 cab-las4/PC-w-...
 cab-4/USB-...
 cab-4/USB-w-...
 cab-4/ETH-500

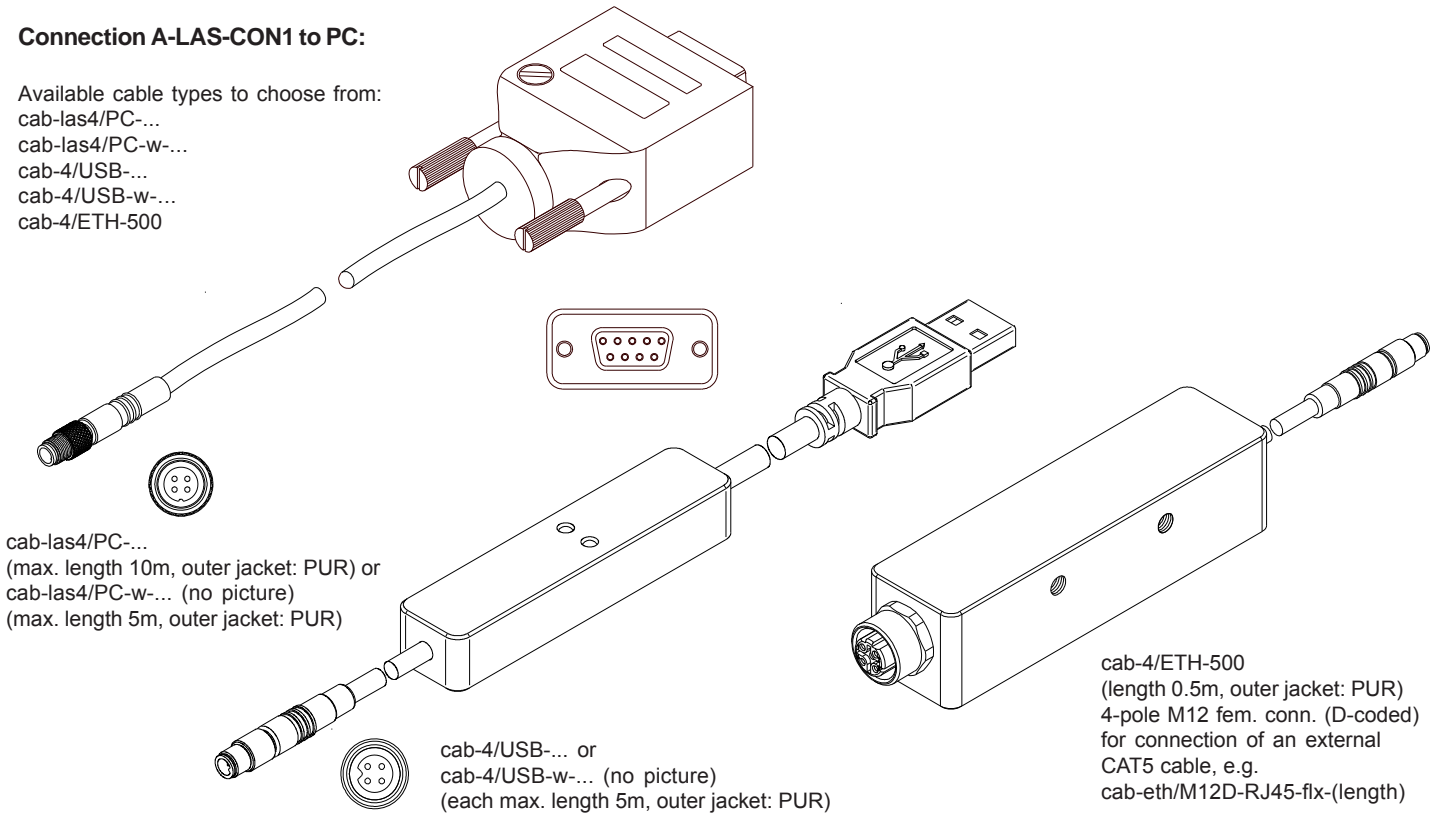

LED Display

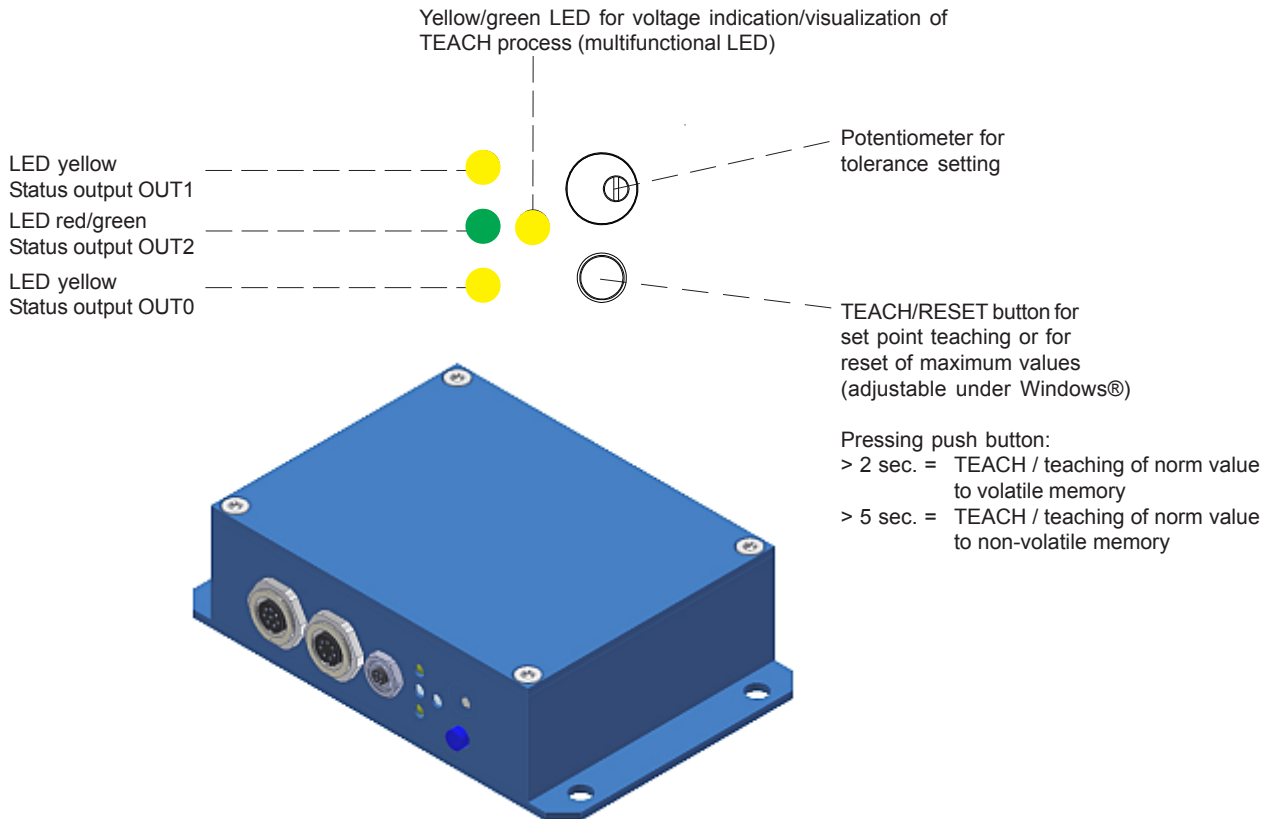



Function Principle

A-LAS-CON1 (or A-LAS-CON1-4/20):

"A-LAS-CON1" is a microcontroller-based control unit for the evaluation of the signals from up to two analog laser sensors of type "A-LAS". The control unit of type "A-LAS-CON1" contains the transmitter and receiver electronics and features two sensors.

The A-LAS-CON1 control unit has two 7-pole female connectors that each allow the connection of an A-LAS sensor by way of a suitable connecting cable (cab-las-y or cab-las-y-male). The analog output signals of the two sensors are read and digitised by the control unit at a rate of up to 25000 times per second. The digital values are then internally processed and evaluated according to user-defined settings. The two sensors (referred to as "channels") are interpreted independently of each other.

The signals are evaluated by way of a tolerance band that is separately defined for each channel and can be freely set within the measuring range. For configuration purposes the A-LAS-CON1 control unit features an RS232 interface through which the settings of the control unit can be accessed with the "A-LAS-CON1-Scope" PC software.

Through an 8-pole female connector the A-LAS-CON1 control units is supplied with a supply voltage of nominal 24V. The states of the individual channels can be output via three short-circuit-proof, freely configurable digital outputs (OUT0, OUT1, OUT2). At the housing of the A-LAS-CON1 the output state is visualised by way of 4 LEDs.

Two digital inputs provide a trigger function for controlling measurement value scanning and/or a teach function for setting new tolerance band values. Through a high-speed analog output (0...+10V or 4...20mA) the measurement values can be output as analog values. A button at the housing of the A-LAS-CON1 control unit allows activation of a TEACH event.

From analog sensor to digital value

- A-LAS sensors generate an analog voltage value that depends on the shadowing of the laser beam arriving at the A-LAS receiver.
- The A-LAS-CON1 control unit in fixed time intervals converts this analog value into a digital value.
- The digital value either is absolutely scaled (RAW VALUE) or relatively scaled (NORM VALUE).
- The scaled value features a factor that varies with time and compensates the following effects: Dirt accumulation at the sensor, changing laser power value, changing distance between transmitter and receiver, and temperature influences.
It is a prerequisite for the scaling process that the laser beam between transmitter and receiver becomes free in recurring intervals.

From digital value to measuring value

- Measurement values are filtered and recalculated in every time interval. Filtering results and calculations are available in parallel.
- The filter options comprise low-pass, minimum value, maximum value, and differentiation filter. Integration is formed in parallel.
- The combination/linking of the two sensors is available as an option.

From measuring value to digital/analog output

- Evaluation (comparison of the measurement value with the upper and lower tolerance threshold) is performed at adjustable times.
- Evaluation can be status-controlled or event-controlled. For this purpose an adjustable evaluation condition must be fulfilled.
- The digital inputs, the analog signal characteristic (through internal trigger thresholds) and/or the internal time delay modules can be used for event- or status control.
- Evaluation is performed when the evaluation condition is fulfilled. The comparison is provided through the digital outputs OUT0 and OUT1 and/or OUT2. The measurement value also can be provided through the analog output.



Parameterisation

Windows® software A-LAS-CON1-Scope:

The A-LAS-CON1-Scope software is used for parameterising the A-LAS-CON1 control unit for sensors of the A-LAS series. The measured values provided by the sensor can be visualised with the PC software, which means that the software among others can be used for adjustment purposes and for setting suitable tolerance limits for the inspection of the measuring object.

Data exchange between the PC user interface and the sensor system is effected through a standard RS232 interface. For this purpose the sensor is connected to the PC with the serial interface cable cab-las-4/PC (or with the USB- cable cab-4/USB or Ethernet adaptor cab-4/ETH-500). When parameterisation is finished, the setting values can be permanently saved in an EEPROM memory of the A-LAS-CON1 control unit. The sensor system then continues to operate in "STAND-ALONE" mode without a PC.

When the A-LAS-CON1-Scope software is started, the following Windows® user interface will be displayed:

For detailed description of parameter setting please cf. software user manual.

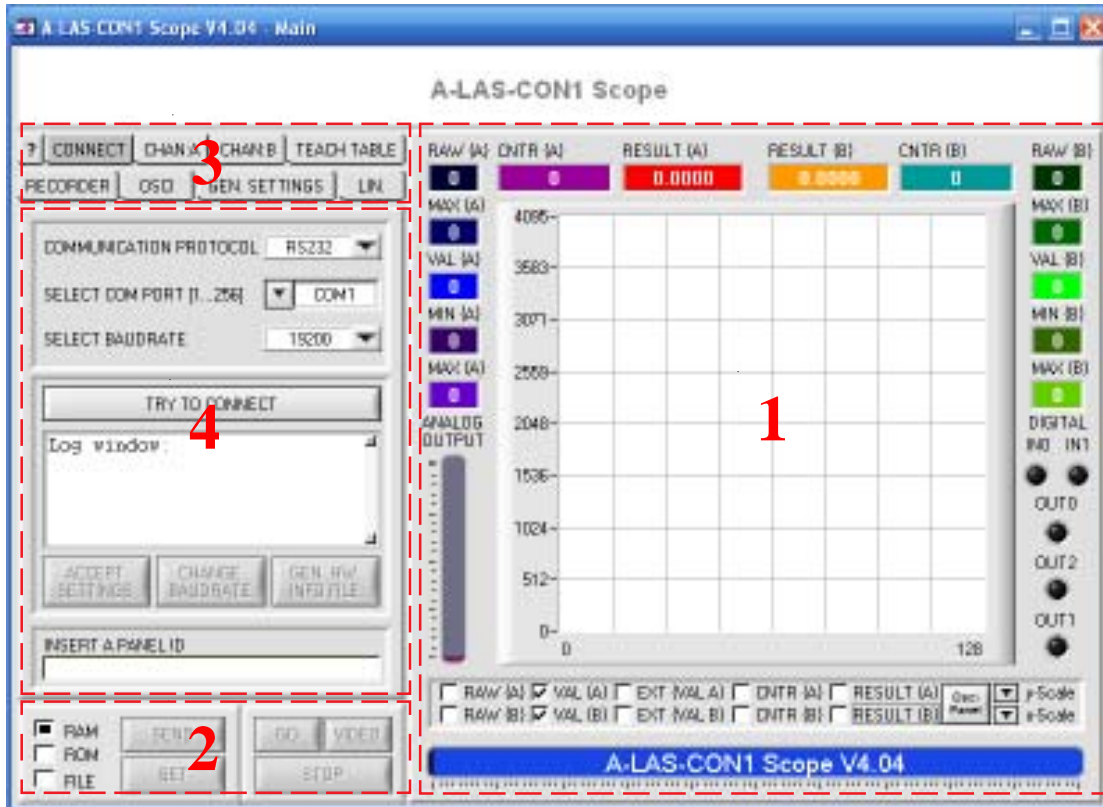

The user interface is divided into four sections:

- The right section (1) contains the numeric displays of the current A-LAS-CON1 data and a scroll graph display that represents the characteristics of the signals. In oscillograph mode two displays for the individual channels are shown instead of the scroll graph.
- Section (2) permanently displays the buttons for controlling data exchange ("GO", "VIDEO" and "STOP") and the buttons for exchanging parameters with the control unit ("SEND" and "GET").
- Individual parameters of the A-LAS-CON1 can be accessed by way of several panels that are arranged centrally at the left side (4).
- The buttons (3) for selecting these panels and thus defining the current display are located at the top of the left side.

The software can be used for:

- Parameterisation of the sensor
- Continuous visualisation of measurement data
- Recording/logging of measurement data on the local hard disk
- Manual TEACHING, resetting, and scaling of the channels
- Copying of linearisation information for the sensors (for linearised operation)
- Reading of the control unit's internal oscilloscope function

