



Mechanical pressure switch

# Huba Control

*In Proud Partnership with Huba Control*

**PAQUIN**  
SENSORS

For technical support, sales, & distribution  
within the USA & Canada

www.paquin.com | (800) 831-8217 | paquinsensors@paquin.com

## Relative pressure switch

### Type 620/625

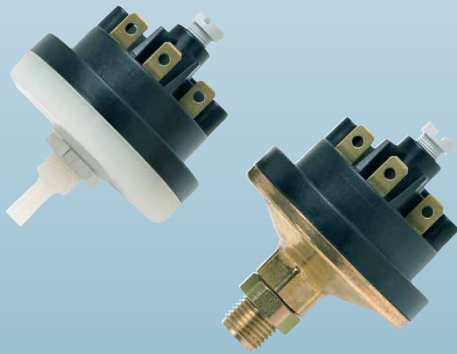

Type 620 and 625 pressure switches, with 13 pressure ranges, are suitable for liquids and gases. Body materials are available in plastic, brass and aluminium, with a choice of NBR, FPM, EPDM and silicone diaphragms.

Very high precision through finely tuned measurement stages and high long term stability. Rugged design and especially suitable for use in general industrial equipment construction, process technology and food automation.

## Pressure range

**-4 ... -900 mbar /  
2 ... 6000 mbar**

- + High accuracy by 13 ideally designed pressure range increments
- + Switching differences adjustable
- + High long term stability with reproducibility of switching points  $< \pm 0.3$  mbar
- + Customer specific switching points adjustable in factory
- + Rugged industrial switch with excellent Price / performance ratio

## Technical overview

### Pressure range

Relative	2 ... 6000 mbar
Negative	-4 ... -900 mbar

### Operating conditions

Medium		Liquids and neutral gases
Temperature	NBR based	0 ... +80 °C
	FPM	-10 ... +80 °C
	EPDM	-10 ... +80 °C
	Q (Silicone)	-40 ... +80 °C
	Ambient	+65 °C
	Storage	-40 ... +80 °C
Tolerable overload		See order code selection table
Lowest turn-on pressure		2 mbar
Lowest switching difference		1 mbar

### Materials

Case		Fibreglass reinforced plastic
Materials in contact with the medium		NBR based
		EPDM
	Diaphragm	FPM
		Silicone
	Base type 620	ABS or PA
	Base type 625	Aluminium, nickel plated brass
Other components		X 5 CrNi 18-10, 1.4301
		Polyacetate (only at negative)

### Electrical overview

Nominal voltage	250 VAC	
Nominal current for resistive loading	1 A	6 A
Nominal current for motor loading	0.5 A	3 A
Contact system	Changeover contact	
Service life	Mechanically	10 <sup>6</sup> switching cycle <sup>1)</sup>

### Protection standard

Without cover	IP 00
With cover <sup>2)</sup>	IP 54

### Repeatability

±5% of the switching point	With diaphragm NBR based / Silicone	minimum ±0.3 mbar
±10% of the switching point	With diaphragm FPM / EPDM	minimum ±0.6 mbar

### Electrical connections

Screw terminals (Option)		
Tab connectors (AMP)		6.3 mm
Cable gland PG 11	with cover	

### Pressure connections

Type 620	Inside / outside thread	M5 / M12x1
Type 625	Connection pipe / thread	Ø 6 mm / M12x1
	Thread with counternut	M12x1 (CuZn nickel plated), G ¼, G ¼

### Installation arrangement

For switching points calibrated in the factory	Indicate installation arrangement.
Remark:	By changing the mounting position the switching points also change. The adjustment ranges are in relation with the mounting position.

### Weight

Type 620		~ 70 g
Type 625	with aluminium base	~ 100 g
	with base brass	~ 200 g

### Packaging

Single packaging in cardboard		
Multiple packaging in cardboard		per 18 pcs.

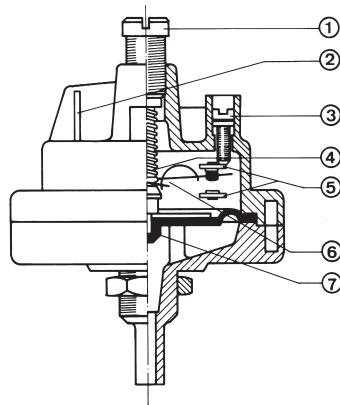

### Legend to cross-section drawing

- 1 Switching point setting
- 2 AMP tab connectors
- 3 Switching difference setting
- 4 Compression spring
- 5 Changeover contact
- 6 Contact element
- 7 Diaphragm

<sup>1)</sup> The permitted switching difference has to be respected

<sup>2)</sup> For installation arrangement electrical connections upward

Order code selection table					1	2	3	4	5
					620.	X	X	X	X
Pressure range <sup>1)</sup>	2 ... 8 mbar	<b>p max.</b> 30 mbar	<b>pt <sup>2)</sup></b> 50 mbar	<b>Switching capacity 250 VAC</b> 1 A	9	1			
	6 ... 75 mbar	300 mbar	500 mbar	1 A	9	2			
	12.5 ... 80 mbar	300 mbar	500 mbar	6 A	9	3			
	12.5 ... 200 mbar	300 mbar	500 mbar	1 A	9	4			
	25 ... 220 mbar	300 mbar	500 mbar	6 A	9	5			
Pressure connection / pressure case	Hose connection Ø 6 mm and M12x1		ABS	... +70 °C				0	
			PA 66	... +80 °C				1	
	Inside thread M5 and M12x1		ABS	... +70 °C				2	
			PA 66	... +80 °C				3	
Diaphragm material	NBR based								0
	FPM								2
	EPDM								4
	Q (Silicone)								6
Switching points (optional)	Two factory set switching points			(please specify on order)					W
	One factory set switching point high			(please specify on order)					R
	One factory set switching point low			(please specify on order)					U

Order code selection table					1	2	3	4	5
					625.	X	X	X	X
Pressure mode	Relative				9				
	Negative				6				
Pressure range <sup>1)</sup>	2 ... 8 mbar	<b>p max.</b> 30 mbar	<b>pt <sup>2)</sup></b> 50 mbar	<b>Switching capacity 250 VAC</b> 1 A	9	0			
	6 ... 75 mbar	300 mbar	500 mbar	1 A	9	1			
	12.5 ... 80 mbar	300 mbar	500 mbar	6 A	9	2			
	12.5 ... 200 mbar	300 mbar	500 mbar	1 A	9	3			
	25 ... 220 mbar	300 mbar	500 mbar	6 A	9	4			
	80 ... 2000 mbar	6000 mbar	10000 mbar	1 A	9	5			
	120 ... 2200 mbar	6000 mbar	10000 mbar	6 A	9	6			
	1000 ... 6000 mbar	6800 mbar	10000 mbar	6 A	9	7			
	-4 ... -30 mbar	-50 mbar	-100 mbar	1 A	6	1			
	-15 ... -80 mbar	-300 mbar	-500 mbar	1 A	6	2			
	-30 ... -150 mbar	-300 mbar	-500 mbar	6 A	6	3			
	-50 ... -600 mbar	-1000 mbar	-1000 mbar	6 A	6	4			
	-100 ... -900 mbar	-1000 mbar	-1000 mbar	6 A	6	5			
Pressure connection / pressure case	G 1/8	Aluminium						1	
		Brass						B	
	M12x1	Aluminium						2	
		Brass						3	
Diaphragm material	G 1/4								4
	Aluminium								A
	Nickel plated brass 5µm								
Switching points (optional)	NBR based								0
	FPM								2
	EPDM								4
	Q (Silicone)								6
Switching points (optional)	Two factory set switching points			(please specify on order)					W
	One factory set switching point high			(please specify on order)					R
	One factory set switching point low			(please specify on order)					U

Accessories <sup>3)</sup>	Order number
Cover of PG11 on the side	105836
Mounting bracket with hole Ø 12.5 mm for M12	104259
Mounting bracket with hole Ø 14 mm for G 1/4	102872
Connector set (Tab connectors AMP)	103479
Screw clamps set	103491
Calibration certificate	104551

<sup>1)</sup> Other pressure ranges on request

<sup>2)</sup> pt = test pressure

<sup>3)</sup> Accessories supplied loose

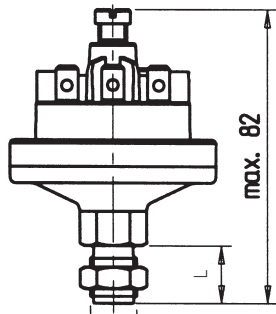
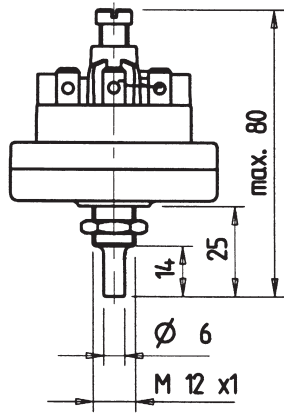

X	L
G 1/4	16
G 3/8	16
M12X1	14

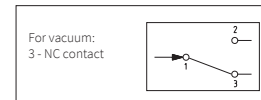
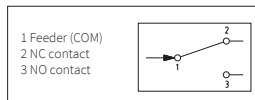
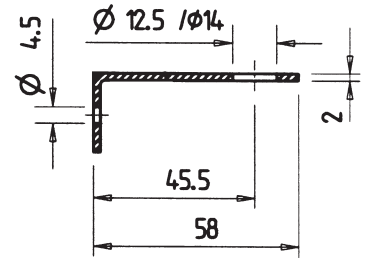
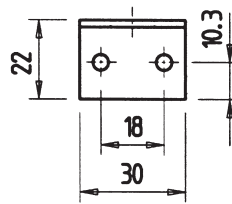
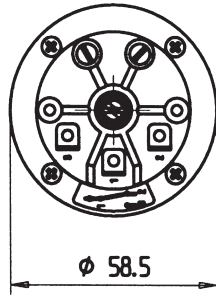
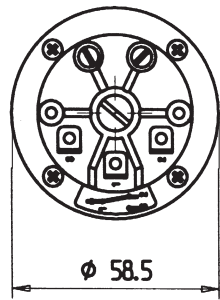
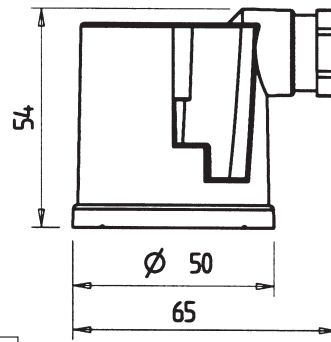

Setting ranges

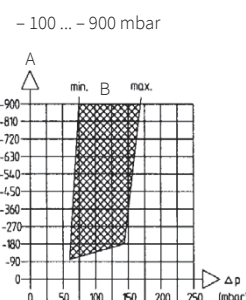
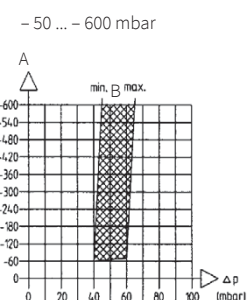
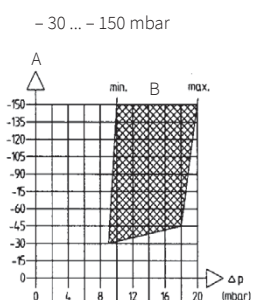
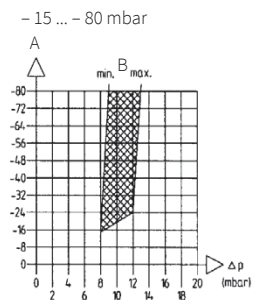
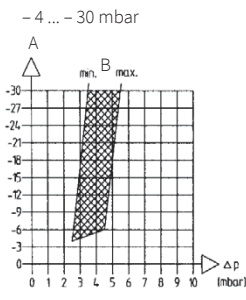
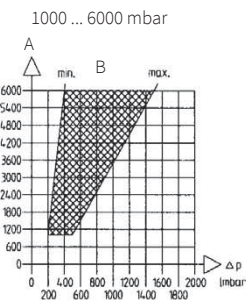
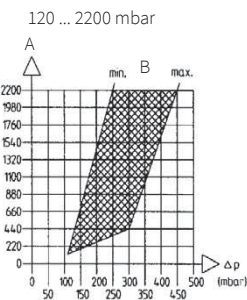
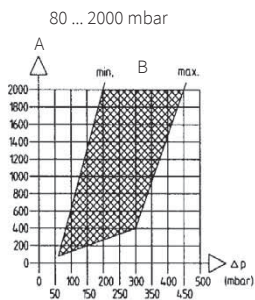
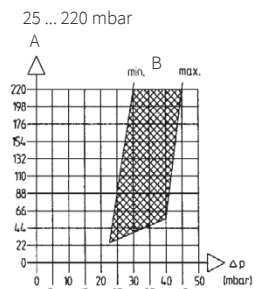
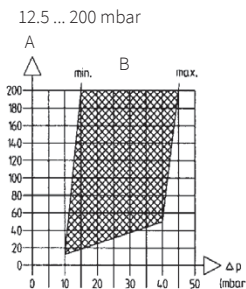
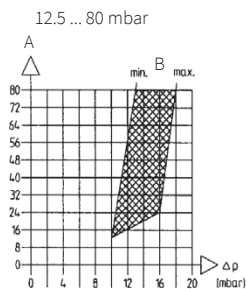
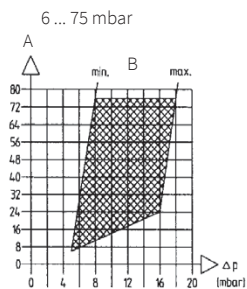
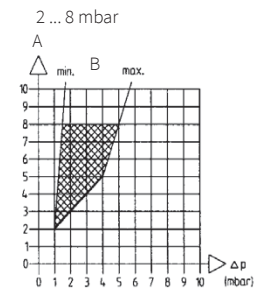

A Upper switching point (mbar)  
B Distance between contacts