



Pressure switch

Huba Control

In Proud Partnership with Huba Control

PAQUIN
SENSORS

For technical support, sales, & distribution
within the USA & Canada

www.paquin.com | (800) 831-8217 | paquinsensors@paquin.com

Pressure Transmitter with display and programmable switching outputs

Type 540

The μ P-regulated, programmable pressure transmitter type 540 has a robust industry design. The parameters are easily adjustable with two function keys in the configuration menu which disposes of up to two programmable switching points.

All systems are equipped with a diagnostic function. The large 4 digit LED display assures a good accuracy of reading.

The pressure transmitter type 540 is based upon the Huba Control developed thick film technology where the pressure measuring cell is fully welded.



Pressure range
0 ... 60 – 600 bar

- + Compact, rugged construction
- + High over pressure
- + Clearly readable display
- + Sensitive operation keys
- + Diagnostic function
- + with analogue signal available
- + by up to 2 programmable switching outputs

Technical overview

Pressure range

Relative 0 ... 60 – 600 bar

Operating conditions

Medium		Liquids and gases
Temperature	Medium / Ambient	-20 ... +80 °C
	Storage	-40 ... +80 °C
Overload		3 x fs (max. 1500 bar)
Rupture pressure		6 x fs (max. 2500 bar)

Materials

Case		Polyarylamid 50% GF black
Materials in contact with medium	Sensor	Stainless steel
	Pressure connection	Stainless steel 1.4404 / AISI 316L

Electrical overview

Output	0 ... 10 V	
	4 ... 20 mA	
	Open-collector switching output for max. 250 mA, contact NO or contact NC	
Power supply		17 ... 33 VDC
Load	0 ... 10 V	> 10 kOhm
	4 ... 20 mA	< 500 Ohm
Current consumption		max. 50 mA
Polarity reversal protection	Short circuit proof and protected against polarity reversal. Each connection is protected against crossover up to max. supply voltage.	

Dynamic response

Response time	≤ 5 ms
Load cycle	< 100 Hz

Displays (rotatable by 180°)

7 Segment LED, 4 digits for the indication of pressure measuring values and parameter values.
 Point-LED for state indication of switching points.
 Point-LED for indication of programmed measuring unit.

Programming

All settings can be made in unpressurised state or during the operation. Ex works with standard setting.

Analogue output: characteristic line adjustable of 75 ... 125% FS

Digital output: Measuring range

rising pressure	8 ... 100% fs
falling pressure	5 ... 97% fs

P or N-switching, open-close-contact, rise delay time eligible Rise delay time 0 – 50 s, Switch off delay time 0 – 50 s, Response time 5 ... 500 ms.

Diagnostic function

Manual operation with keyboard: Test of sensor circuit and of stainless steel cell. Version available with diagnostic function.
 Version with diagnostic input (shunt-cal): feed-back with 50% fs signal 12 mA or 5 V.

Electrical connection	Protection standard	Protection class
Connector M12x1	IP 65 and IP 67 acc. IEC 60529	III

Pressure connection

Inside thread	G 1/4	with O-Ring sealing FPM
	7/16 - 20 UNF	sealed at front SAE J1926-1, ISO 11926-1
	1/4 -18 NPT	
Outside thread	1/4 -18 NPT	
	G 1/4	sealed at back ISO 1179-2 (DIN 3852-E) with profile seal ring FPM
	R 1/4	EN 10226
	7/16 - 20 UNF	sealing cone 45°

Installation arrangement

Unrestricted (Electrical connection not recommended down)

Tests / Admissions

Electromagnetic compatibility	CE conformity acc. EN 61326-2-3
UL acc. 61010-1	
Shock acc. IEC IEC 68-2-27	100 g, 11 ms half sine wave, all 6 directions, free fall from 1 m on concrete (6x)
Vibration acc. IEC 68-2-6	20 g, 15 ... 2000 Hz, 15 ... 25 Hz with amplitude ± 15 mm, 1 Octave/min. all 3 directions, 50 constant load
Drinking water approval	NSF/ANSI 61/372 acc. MH60087
EAC	WRAS

Weight

~ 120 g

Packaging

Single packaging in cardboard

Accuracy

Parameter

Unit

Characteristic line ¹⁾	% fs	± 1.0
Thermal characteristic ²⁾	max. % fs/10K	± 0.65
Long term stability acc. IEC EN 60770-1	max. % fs	± 0.3

Test conditions: 25 °C, 45% RH, power supply 24 VDC

¹⁾ typical; (incl. zero point, full scale, linearity, hysteresis and repeatability)

²⁾ -15 ... 85 °C

Order code selection table					1	2	3	4	5	6	7	8	9	10
					540.	X	X	X	X	X	X	X	X	X
Pressure range ¹⁾ (adjustment in bar)	bar	psi	kPa	MPa										
	0 ... 60	0 ... 870	0 ... 100	0 ... 6	9	4	0	S						
	0 ... 100	0 ... 1450		0 ... 10	9	4	1	S						
	0 ... 160	0 ... 2320		0 ... 16	9	4	2	S						
	0 ... 250	0 ... 3625		0 ... 25	9	4	3	S						
	0 ... 400	0 ... 5800		0 ... 40	9	5	4	S						
0 ... 600	0 ... 8700		0 ... 60	9	5	5	S							
Pressure range ¹⁾ (adjustment in psi)	psi	bar	kPa	MPa										
	0 ... 750	0 ... 52	0 ... 5172	0 ... 5.17	9	D	0	S						
	0 ... 1000	0 ... 69	0 ... 6897	0 ... 6.90	9	D	1	S						
	0 ... 2000	0 ... 138		0 ... 13.79	9	D	2	S						
	0 ... 3000	0 ... 207		0 ... 20.69	9	D	3	S						
	0 ... 5000	0 ... 345		0 ... 34.48	9	E	4	S						
0 ... 7500	0 ... 517		0 ... 51.72	9	E	5	S							
Pressure indication	bar								0					
	psi								1					
	MPa								3					
Output	1 analogue output	4 ... 20 mA	diagnostic input						0	0				
		0 ... 10 V	diagnostic input						1	0				
		4 ... 20 mA	1 digital output						2	1,2				
		0 ... 10 V	1 digital output						3	1,2				
	2 digital outputs								4	1,2				
	2 digital outputs	4 ... 20 mA	1 analogue output						5	1,2				
	0 ... 10 V	1 analogue output						6	1,2					
Electrical connection ²⁾	M12x1 without digital output								0					
	M12x1 NPN								1					
	M12x1 PNP								2					
Pressure connection	Inside thread	7/16 -20 UNF sealed at front SAE J1926-1, ISO 11926-1									A	0	1	
		G 1/4 with O-ring sealing FPM									1	0	1	
		1/4 -18 NPT										D	0	1
	Outside thread	7/16 -20 UNF sealing cone										2	0	1
		1/4 -18 NPT										3	0	1
		G 1/4 sealed at back ISO 1179-2 (DIN 3852-E) with profile seal ring FPM										4	0	1
	R 1/4 acc. EN 10226										7	0	1	

Accessories (supplied loose)				Order Number
Mounting bracket with screw				118716
Heat sink with outside thread G 1/2 - inside thread G 1/4				105073
Heat sink with outside thread G 1/4 - inside thread G 1/4				105074
Straight-wire box for connector M12x1 with cable		5-pole	200 cm	114564
Straight-wire box for connector M12x1 with cable (with UL-admission)		5-pole	200 cm	118099
Calibration certificate (available for analogue output, only)				104551

¹⁾ Other pressure on request

²⁾ Delivery without female connector

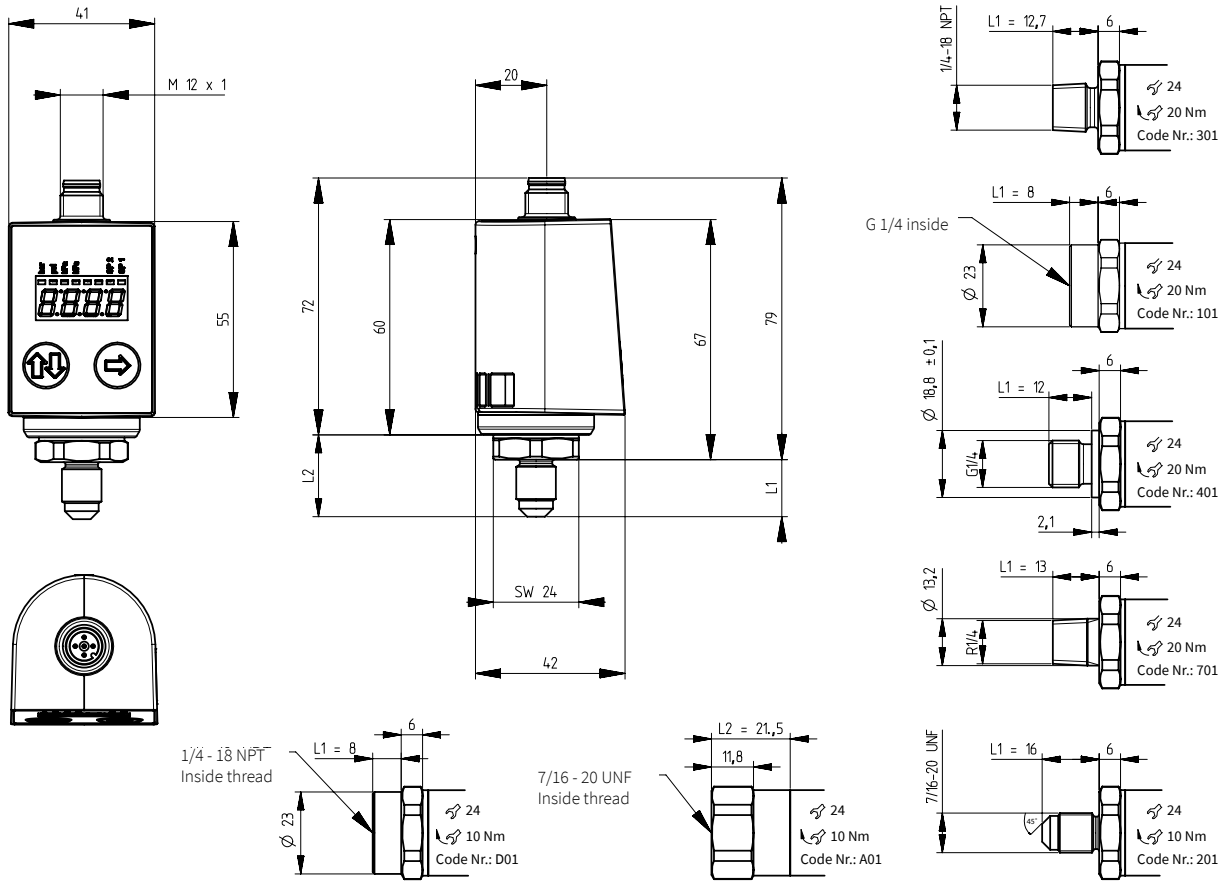

PNP

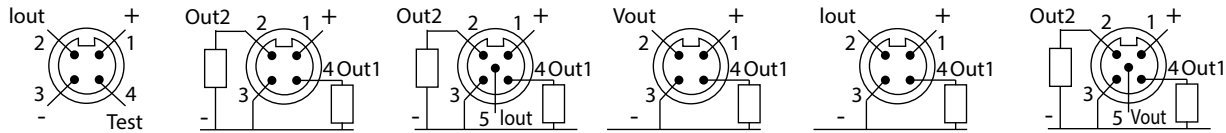

Pin	Colour
1	brown
2	white
3	blue
4	black
5	grey

NPN

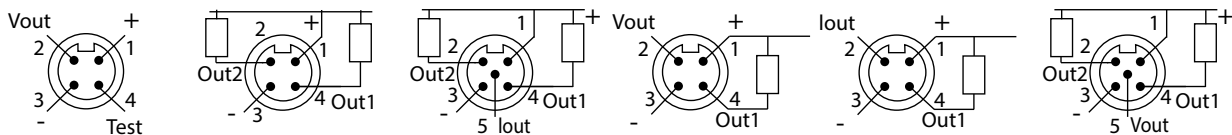

Mounting bracket

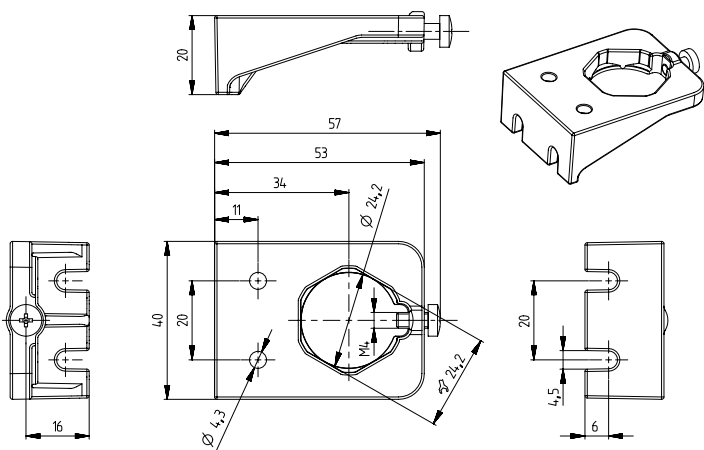

Heat sink

